



Buy Now



License #2011747

1978 Truck Shop Manual

Discover more ebooks! Visit our website: fordshopmanual.com



DEMO

This DEMO contains only a few pages of the entire manual/product.

Not all Bookmarks work on the Demo, but they do on the full version.

Features:

- Searchable text
- Printable pages
- Bookmarked for easy navigation
- High Resolution images
- Zoom to see exact details
- Money back Guarantee
- Transfer to USB flash drive support

Complete 5 Volume Set

Volume 1 - Chassis

Volume 2 - Engine

Volume 3 & 4 - Body and Electrical

Volume 5 - Pre-Delivery, Maintenance and Lubrication

Copyright © 2012, Forel Publishing Company, LLC, Woodbridge, Virginia

All Rights Reserved. No part of this book may be used or reproduced in any manner whatsoever without written permission of Forel Publishing Company, LLC. For information write to Forel Publishing Company, LLC, 3999 Peregrine Ridge Ct., Woodbridge, VA 22192

1978 Ford Truck Shop Manual

EAN: 978-1-60371-086-2

ISBN: 1-60371-086-8

Forel Publishing Company, LLC
3999 Peregrine Ridge Ct.
Woodbridge, VA 22192



This publication contains material that is reproduced and distributed under a license from Ford Motor Company. No further reproduction or distribution of the Ford Motor Company material is allowed without the express written permission of Ford Motor Company.

Note from the Publisher

This product was created from the original Ford Motor Company's publication. Every effort has been made to use the original scanned images, however, due to the condition of the material; some pages have been modified to remove imperfections.

Disclaimer

Although every effort was made to ensure the accuracy of this book, no representations or warranties of any kind are made concerning the accuracy, completeness or suitability of the information, either expressed or implied. As a result, the information contained within this book should be used as general information only. The author and Forel Publishing Company, LLC shall have neither liability nor responsibility to any person or entity with respect to any loss or damage caused, or alleged to be caused, directly or indirectly by the information contained in this book. Further, the publisher and author are not engaged in rendering legal or other professional services. If legal, mechanical, electrical, or other expert assistance is required, the services of a competent professional should be sought.



1978 Truck Shop Manual Volume 1 Chassis

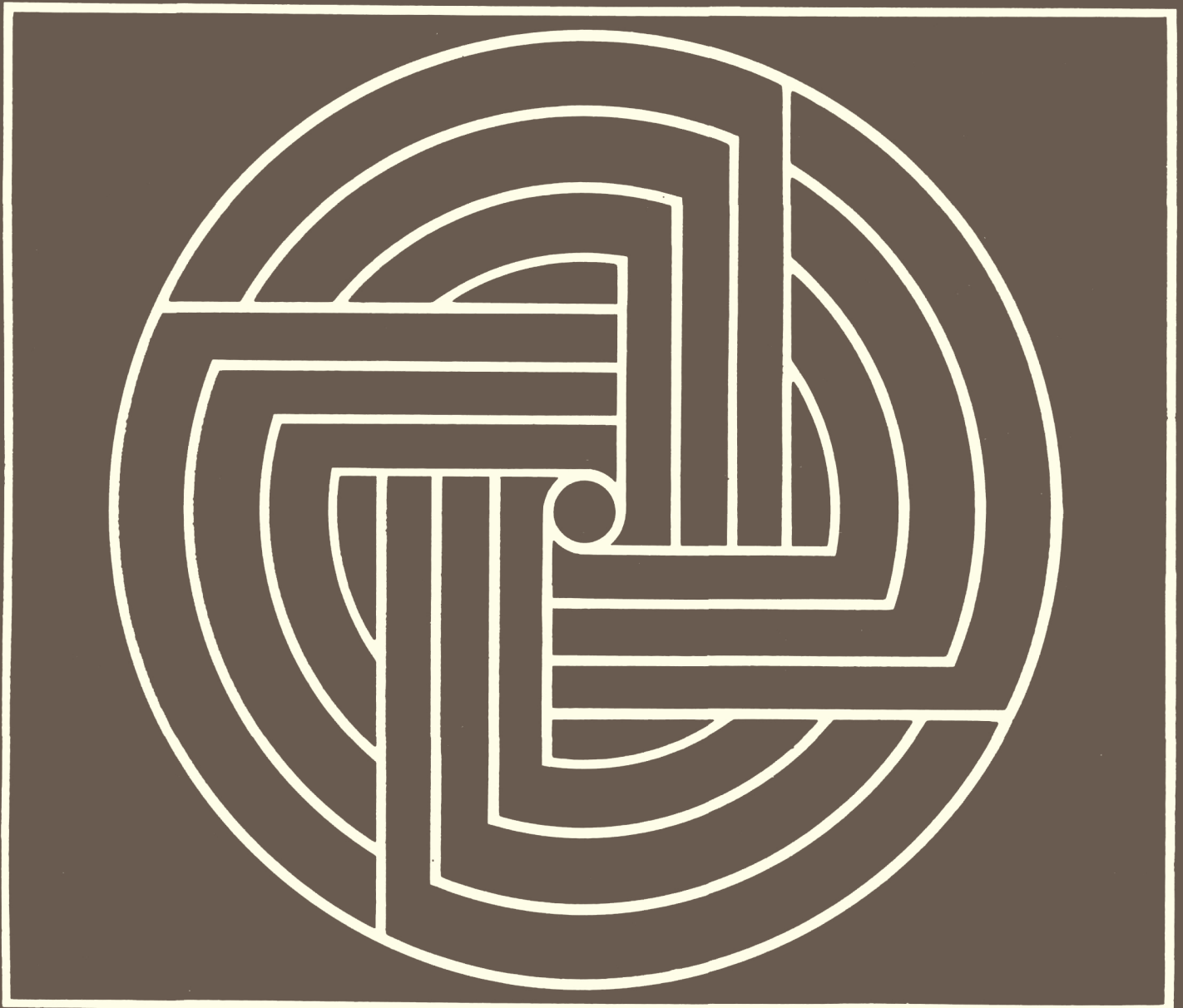

GROUP AND PART INDEX

**IDENTIFICATION
CODES
GROUP 10**
IDENTIFICATION CODES 10-00-1

**WHEELS AND TIRES
GROUP 11
(1000 & 2000)**
GENERAL WHEEL AND TIRE SERVICE 11-01-1
WHEEL HUBS AND BEARINGS — Front (Except Front Drive) 11-10-1
 — Front Wheel Drive 11-12-1
 — Rear (Semi-Floating Axle) 11-11-1
 — Rear (Full Floating Axle) 11-14-1
WHEELS AND TIRES — Drop Center Rim 11-02-1
 — Three-Piece Rims 11-04-1
 — Two-Piece Rims 11-03-1

**BRAKES
GROUP 12
(2000)**
AIR BRAKES — Cam Type 12-48-1
AIR/HYDRAULIC INTENSIFIER 12-42-1
ANTI-LOCK BRAKE SYSTEMS 12-41-1
DISC BRAKES — Light and Heavy Duty Sliding Caliper 12-24-1
 — Heavy Duty 12-25-1
DRUM BRAKES — Dual Cylinders, Dual Pistons 12-08-1
 — Dual Cylinders, Single Piston (Wagner) 12-09-1
 — Single Cylinder, Dual Pistons 12-02-1
 — Single Cylinder, Single Piston 12-05-1
GENERAL AIR BRAKE SERVICE 12-40-1
GENERAL HYDRAULIC BRAKE SERVICE 12-01-1
PARKING BRAKE — Anchor Lok, Rear Wheels, Air 12-87-1
 — Cable Actuated, Rear Wheels 12-70-1
 — External Band, Transmission Mounted 12-77-1
 — Internal Shoe, Transmission Mounted 12-79-1
 — Internal Shoe, Transfer Case Mounted 12-81-1
 — Maxibrake, Rear Wheels, Air 12-83-1
 — MGM Stoppard — Rear Wheels, Air 12-84-1
VACUUM BRAKE BOOSTER — Single Diaphragm, Dash Mounted (Bendix) 12-50-1
 — Single Diaphragm, Dash Mounted (Midland) 12-58-1
 — Single Diaphragm, Frame Mounted (Bendix) 12-53-1
 — Single Diaphragm, Frame Mounted (Midland) 12-60-1
 — Tandem Diaphragm, Dash Mounted (Bendix) 12-52-1
 — Tandem Diaphragm, Frame Mounted (Bendix) 12-54-1

**STEERING
GROUP 13
(3000)**
GENERAL STEERING SERVICE 13-01-1
INTEGRAL POWER STEERING GEAR — Ford 13-41-1
 — Saginaw 13-42-1
 — Ross HF-54, HF-64 13-44-1
 — Ross HFB-52 13-45-1
MANUAL STEERING GEAR — Recirculating Ball 13-33-1
 — Worm and Roller 13-34-1
POWER STEERING PUMP — Eaton 13-51-1
 — Saginaw 13-52-1
 — C II 13-53-1
STEERING COLUMN 13-06-1
 — Floor Mounted Shift Control 13-07-1
 — Shift Rod Above Tube 13-05-1
STEERING LINKAGE — Manual 13-24-1
 — Power Cylinder/Control Valve 13-23-1
 — Power Gear/Power Cylinder 13-22-1

**SUSPENSION
GROUP 14
(3000 & 5000)**
FRONT SUSPENSION — Solid I-Beam 14-20-1
 — Twin I-Beam 14-21-1
 — 4-Wheel Drive 14-22-1
GENERAL SUSPENSION SERVICE 14-01-1
REAR SUSPENSION — Hendrickson Tandems 14-40-1
 — Leaf Springs 14-31-1
 — Reyco 101 Tandem 14-41-1

GROUP AND PART INDEX (CONT'D)

DRIVE SHAFT — Double Cardan-Type U-Joint15-66-1
 — Single Snap Ring Type U-Joint15-60-1
 — Single Bearing Cap and Bolt-Type U-Joint and Bolted End Cap Type U-Joint15-62-1
FRONT DRIVING AXLE — Rockwell15-33-1
 — 44F-9F-Dana15-30-1
 — 60-7F-Dana15-32-1
GENERAL DRIVING AXLE AND DRIVE SHAFT SERVICE15-01-1
INTEGRAL CARRIER AXLE — Dana15-05-1
LIMITED SLIP DIFFERENTIAL — Dana15-42-1
REMOVABLE CARRIER AXLE — Ford15-10-1
ROCKWELL TANDEM AXLES — Top Mounted15-52-1
SINGLE-SPEED, SINGLE REDUCTION AXLE — Eaton15-15-1
 — Rockwell15-16-1
TANDEM AXLE — Eaton15-50-1
 — Rockwell15-51-1
TRACTION-LOK LIMITED SLIP DIFFERENTIAL — Ford15-40-1
2-SPEED DOUBLE REDUCTION AXLE — Eaton15-20-1

DRIVING AXLES AND DRIVESHAFTS
GROUP 15
(4000)

CLARK — 280 Five-Speed Transmission16-40-1
 — 390 Five-Speed Transmission16-39-1
CLUTCH16-02-1
FORD 3.03 THREE SPEED TRANSMISSION16-11-1
 — Four-Speed Over-Drive Transmission16-30-1
FULLER — RT-610 Ten-Speed Transmission16-60-1
 — RT-613 Thirteen-Speed Transmission16-63-1
 — RT-906 Six-Speed Transmission16-22-1
 — RT-9509 and RT-12509 — Nine-Speed Transmission16-66-1
 — RT-RTO-910, RT-1110 and RT-12510 Ten-Speed Transmissions16-61-1
 — RT-RTO-12513 and RT-RTO-9513 Thirteen-Speed Transmission16-65-1
 — T-905-B Five-Speed Transmission16-46-1
GENERAL CLUTCH SERVICE16-01-1
GENERAL MANUAL TRANSMISSION SERVICE16-10-1
HYDRAULIC CLUTCH CONTROLS16-04-1
MECHANICAL CLUTCH LINKAGE16-03-1
NEW PROCESS 203 FULL TIME TRANSFER CASE16-85-1
NEW PROCESS PART TIME 205 TRANSFER CASE16-84-1
NEW PROCESS 435 FOUR-SPEED TRANSMISSION16-25-1
NEW PROCESS 542 FIVE-SPEED TRANSMISSION16-26-1
ROCKWELL T-223 — C1 Transfer Case16-83-1
SPICER — Auxiliary Transmission16-70-1
 — CM-50 and CM-60 Five-Speed Transmission16-42-1
 — RP-8516-3A Sixteen-Speed Compound Transmission16-64-1
 — SST-10073A Transmission16-56-1
WARNER T18 FOUR-SPEED TRANSMISSION16-23-1
WARNER T19 FOUR-SPEED TRANSMISSION16-24-1

CLUTCH AND MANUAL TRANSMISSION
GROUP 16
(7000)

AT-540 AUTOMATIC TRANSMISSION17-27-1
C6 AUTOMATIC TRANSMISSION17-10-1
C4 AUTOMATIC TRANSMISSION17-05-1
GENERAL AUTOMATIC TRANSMISSION SERVICE17-01-1
MT-SERIES AUTOMATIC TRANSMISSION17-30-1
SHIFT CONTROL LINKAGE17-02-1

AUTOMATIC TRANSMISSION
GROUP 17
(7000)

NOISE, VIBRATION AND HARSHNESS DIAGNOSIS18-01-1

NOISE, VIBRATION AND HARSHNESS DIAGNOSIS
GROUP 18

foreword...

This 1978 Truck Shop Manual has been prepared to provide information covering normal service repairs and maintenance for 1978 Ford Trucks manufactured in the United States and Canada. It is divided into five volumes, each covering a specific major area:

- Volume 1 — Chassis
- Volume 2 — Engine
- Volumes 3 & 4 — Body and Electrical
- Volume 5 — Pre-Delivery, Maintenance and Lubrication.

Information in each volume is divided into Groups covering a general system. The table of contents on the cover of each volume indicates the Group title, number, and volume in which each Group is located.

For 1978, the basic part number for components covered in the Group is also included in parenthesis after the Group number.

Example:

<u>Cooling System</u> General System Covered in Group	Group 27	<u>(8000)</u> Basic Part Number for Cooling System Components
-------------------------------------------------------------	----------	------------------------------------------------------------------------

Some components covered within a Group do not have the same basic part number. In these cases, more than one basic part number will appear on the Group index.

Example:

<u>Gasoline Engines</u> General System Covered in Group	Group 21	<u>(6000)</u> Basic Part Number for Gasoline Engine Components	&	<u>9000)</u> Intake and Exhaust Manifold Basic Part Number Only
---------------------------------------------------------------	----------	-------------------------------------------------------------------------------	---	-----------------------------------------------------------------------------

For easy reference, information in each Group has been divided into smaller units or Parts. There is one Part for each component in the system, as well as a General Service Part in some Groups to cover procedures common to several components within the Group. In general, each Part contains the Description, Operation, Diagnosis and Testing, Removal and Installation and Disassembly and Assembly procedures for the component covered in the Part. Diagnosis Charts are also included in some Parts to help you systematically locate and correct problems encountered. In most cases, specifications are included at the end of each Part.

To aid in locating specific items in this manual, the index at the front of each volume provides an alphabetical listing, with page number, for all Parts in the volume. The tab locator on the right side of this index will help you find the first page of each Group.

On the first page of each Group there is an index listing the Part title and Part number for each component covered within the Group. The first page of each Part contains an index to locate service operations covered in that Part. This Group-Part breakdown is also indicated in the page number located at the top of each page.

Example: 11-02-21 = (Group) 11 — (Part) 02 — (Page) 21

Metric conversion tables have been included at the back of each volume to aid in converting specifications in this manual to the metric equivalent.

The descriptions and specifications in this manual were in effect at the time this manual was approved for printing. Ford Motor Company reserves the right to discontinue models at any time, or change specifications or design without notice and without incurring obligation.

IMPORTANT SAFETY NOTICE

Appropriate service methods and proper repair procedures are essential for the safe, reliable operation of all motor vehicles as well as the personal safety of the individual doing the work. This Shop Manual provides general directions for accomplishing service and repair work with tested, effective techniques. Following them will help assure reliability.

There are numerous variations in procedures, techniques, tools, and parts for servicing vehicles, as well as in the skill of the individual doing the work. This Manual cannot possibly anticipate all such variations and provide advice or cautions as to each. Accordingly, anyone who departs from the instructions provided in this Manual must first establish that he compromises neither his personal safety nor the vehicle integrity by his choice of methods, tools or parts.



**Ford Parts and Service Division
Training and Publications Department**

IDENTIFICATION CODES

**GROUP
10**

Identification Codes

**PART
10-00**

APPLIES TO ALL MODELS

SUBJECT	PAGE	SUBJECT	PAGE
RATING PLATE00-1	VEHICLE DATA (Cont'd)	
VEHICLE CERTIFICATION DECAL00-1	Exterior Paint Color Codes00-7
VEHICLE DATA00-1	Max. GVW Codes00-8
Assembly Plant Codes00-6	Sequential Serial and Warranty Number Codes00-6
Axle Codes (Front)00-14	Transmission Codes00-12
Axle Codes (Rear)00-13	Truck Series Codes00-4
Body Codes00-12	Type/GVW Codes00-8
D.S.O. Codes00-14	Wheelbase Codes00-7
Engine Codes00-5	VEHICLE IDENTIFICATION NUMBER00-1

GENERAL INFORMATION

VEHICLE CERTIFICATION DECAL

The Vehicle Certification Decal (V.C. Decal) is attached to the rear face of the driver's door or door pillar (Fig. 1). The upper half of the decal contains the name of the manufacturer, the month and year of manufacture and the certification statement. The V.C. Decal also contains the Vehicle Identification Number.

The remaining information codes on the V.C. Decal are the same as the Truck Rating Plate Codes (Fig. 2). Vehicle codes shown on the Truck Rating Plate are explained in the following paragraphs.

RATING PLATE

Fig. 2 illustrates a typical Truck Rating Plate. On light and medium cowl and windshield vehicles, the Rating Plate is mounted on the right side of the cowl top panel under the hood. On stripped Parcel Delivery vehicles, the rating plate is placed in an envelope stapled to the dunnage box. On Bronco models, the plate is mounted on the inside panel of the glove compartment door. On all other vehicles, the Rating Plate is mounted on the rear face of the left front door.

VEHICLE IDENTIFICATION NUMBER (VEHICLE SERIAL AND WARRANTY)

The identification number is the first line of numbers and letters appearing on the Rating Plate (Fig. 2). The first letter and two numbers indicate the truck series code. The letter following the truck series code designates the engine identification code. The letter following the engine identification code indicates the assembly plant at which the vehicle was built. The remaining numbers indicate the consecutive unit number (Serial and warranty number). The charts that follow list the various vehicle identification number codes.

VEHICLE DATA

The Vehicle Data appears on the Rating Plate on the two lines following the identification number. The first three digits under W.B. designate the wheelbase in inches. The one or two letters under COLOR identify the exterior paint color (two letters designate a two-tone). The letter and three digits

under TYPE/G.V.W. designate the truck model within a series and the gross vehicle weight rating. The letter and numerals under BODY designate the interior trim, seat and body type. The transmission installed in the vehicle is identified under TRANS by either a numeric or alphabetical code (if two symbols appear, the first identifies the auxiliary transmission, if so equipped, and the second symbol identifies the main transmission). A letter and a number or two numbers under AXLE identify the rear axle ratio (when required, a letter is also stamped behind the rear axle code to identify the front axle capacity). The maximum gross vehicle weight in pounds is stamped under MAX. G.V.W.

A two-digit number is stamped under D.S.O. to identify the district which ordered the vehicle. If the vehicle is built to special order (Domestic Special Order, Foreign Special Order, Limited Production Option, or other special order), the complete order number will also appear under D.S.O. The charts that follow Figure 2 list the various vehicle data codes.

COMPLETE VEHICLES

(UNITED STATES)

①	MFD. BY FORD MOTOR CO. IN U.S.A.				⑦			
②	08/77	GYWR:	5750 LB/2608 KG		⑧			
③	FRONT GAWR:	2870LB	REAR GAWR	3218 LB	⑨			
④	1301 KG	WITH	1459 KG	WITH	⑩			
⑤	H78 — 15B	TIRES	H78 — 15B	TIRES	⑪			
⑥	15 x 5.5K	RIMS	15 x 5.5K	RIMS	⑫			
	AT 30 PSI COLD		AT 32 PSI COLD		⑬			
THIS VEHICLE CONFORMS TO ALL APPLICABLE FEDERAL MOTOR VEHICLE SAFETY STANDARDS IN EFFECT ON THE DATE OF MANUFACTURE SHOWN ABOVE.								
VEH IDENT NO. E04BHAE0000		F0187		T0571				
TYPE TRUCK								
COLOR	DSO	BODY	TRIM	SCH.	DATE	AXLE	TRANS	A/C

(CANADA)

MFD, BY FORD MOTOR CO. OF CANADA LTD.								
GYWR:								
FRONT GAWR:		REAR GAWR:		WITH TIRES	WITH TIRES			
	WITH TIRES			RIMS	RIMS			
AT	PSI COLD	AT	PSI COLD					
THIS VEHICLE CONFORMS TO ALL APPLICABLE FEDERAL MOTOR VEHICLE SAFETY STANDARDS IN EFFECT ON THE DATE OF MANUFACTURE SHOWN ABOVE								
VEH. IDENT. NO.		CANADA BUILT UNITS						
TYPE		UTILITZE SAME TYPE DATA AS U.S.A.						
COLOR	DSO	BODY	TRIM	SCH.	DATE	AXLE	TRANS	A/C
MADE IN CANADA								

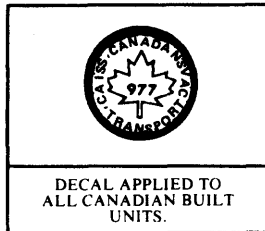

INCOMPLETE VEHICLES

THE INCOMPLETE VEHICLE LABEL IS ATTACHED TO A BOOKLET (INCOMPLETE VEHICLE MANUAL) AND SECURED TO A SUITABLE INTERIOR LOCATION FOR INFORMATION USE AT DESTINATION.

(UNITED STATES)

THIS INCOMPLETE VEHICLE MFD. BY FORD MOTOR COMPANY THE AMERICAN ROAD DEARBORN, MICHIGAN 48121 ON: 08/77			
VEH. IDENT. NO. E37HHA0002			
GVWR 1000 LB/4335 KG			
FRONT GAWR	REAR GAWR	REAR	REAR GAWR
4000 LB	6700 LB		LB
1814 KG	3039 KG		KG
FRONT		REAR	
8.00 — 16.5E		8.00 — 16.5E	
16.5 x 6.0		16.5 x 6.0	
60		55	
TIRES			
RIMS			
PSI COLD			
MAY BE COMPLETED AS: TRUCK BUS (NOT SCHOOL BUS)			

(EXPORT)

THIS INCOMPLETE VEHICLE MFD. BY FORD MOTOR COMPANY THE AMERICAN ROAD DEARBORN, MICHIGAN 48121 ON: 08/77			
VEH. IDENT. NO.			
GVWR			
FRONT GAWR	REAR GAWR	REAR	REAR GAWR
FRONT		REAR	
TIRES			
RIMS			
PSI COLD			
MAY BE COMPLETED AS:		THIS VEHICLE MFD FOR EXPORT ONLY ON DATE SHOWN ABOVE	

NOTE — The same information is on all safety certification decal although the location of the information on the decal may be different.

- ① Name of Manufacturer
- ② Date of Manufacture
- ③ Front Gross Axle Weight Ratings in Pounds (LB) and Kilograms (KG)
- ④ Front Tire Size
- ⑤ Rim Size
- ⑥ Front Tire Cold PSI
- ⑦ Gross Vehicle Weight Rating in Pounds (LB) and Kilograms (KG)

- ⑧ Rear Gross Axle Weight Rating In Pounds (LB) and Kilograms (KG)
- ⑨ Rear Tire Size
- ⑩ Rim Size
- ⑪ Rear Tire Cold PSI
- ⑫ Vehicle Identification Number (See Fig. 2 for details)
- ⑬ Vehicle Data (See Fig. 2 for details)

FIG. 1 Typical Vehicle Certification Decal

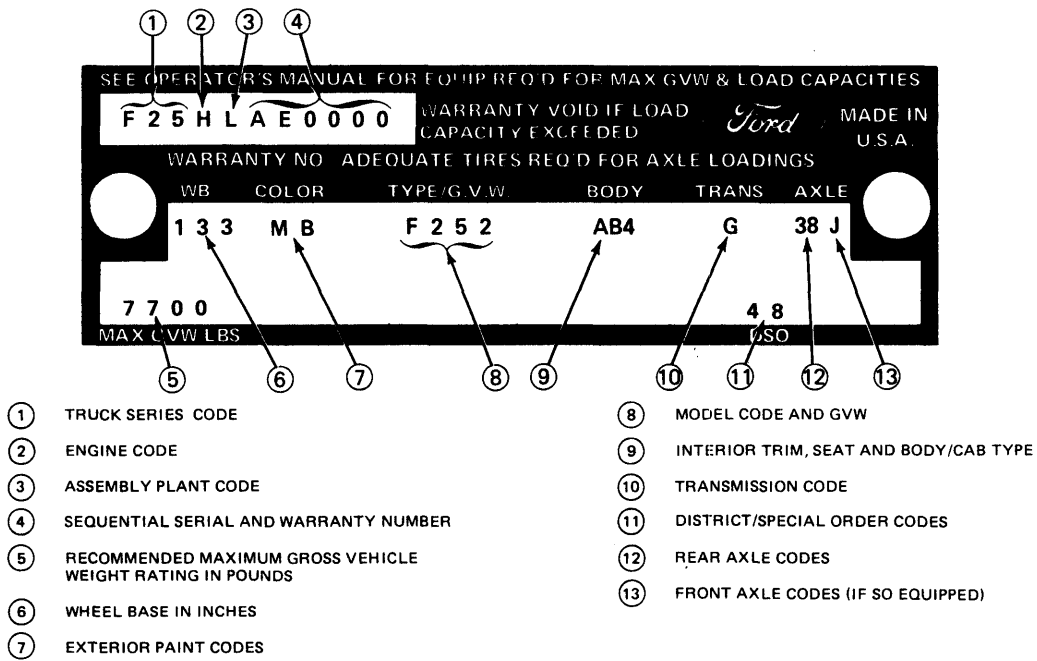

W1017-L

FIG. 2 Typical Truck Rating Plate

TRUCK SERIES CODES

OPERATOR'S MANUAL FOR EQUIPMENT FOR MAX GVW & LOAD CAPACITIES
 (ARRANGEMENTS VARY) (LOAD CAPACITY EXCEEDED)
 (ARRANGEMENTS VARY) (ADEQUATE THIS REED FOR AXLE LOADINGS)
 F 2 5 H L A E 0 0 0
 1 3 3 M B F 2 5 2 AB4 G 38 J
 7 7 0 0
 4 8
 DSO

Code	Description
U15	U-150 (Wagon) 4x4

E-100 THRU E-350

Conventional Code	Super Code	Description
E-100 Series		
E01	—	E100 Club Wagon 5 Passenger
E02	—	E100 Club Wagon 8 Passenger
E04	—	E100 Cargo Van
E05	—	E100 Window Van
E06	—	E100 Display Van

E-150 Series		
E11	S11	E150 Club Wagon 5 Passenger
E12	S12	E150 Club Wagon 8 Passenger
E14	S14	E150 Cargo Van
E15	S15	E150 Window Van
E16	S16	E150 Display Van

E-250 Series		
E20	S20	E250 Club Wagon 11 Passenger
E21	S21	E250 Club Wagon 5 Passenger
E22	S22	E250 Club Wagon 8 Passenger
E23	S23	E250 Club Wagon 12 Passenger
—	S29	E250 Club Wagon 15 Passenger
E24	S24	E250 Cargo Van
E25	S25	E250 Window Van
E26	S26	E250 Display Van

E-350 Series		
E30	S30	E350 Club Wagon 11 Passenger
—	S32	E350 Club Wagon 8 Passenger
—	S33	E350 Club Wagon 12 Passenger
—	S39	E350 Club Wagon 15 Passenger
E34	S34	E350 Cargo Van
E35	S35	E350 Window Van
E36	S36	E350 Display Van

Econoline "Cutaway" Model		
E27	—	E250 Cutaway
E37	—	E350 Cutaway

Parcel Delivery		
E28	—	E250 Cutaway
E38	—	E350 Cutaway

F-SERIES CONVENTIONAL — GAS

Chassis Cab Code	Pick-Up Code	Basic Series
F17	F10	F100
F16	F14	F150 4x4
F19	F15	F150
F27	F25	F250
F28	F26	F250 4x4
F37	F35	F350

F-SERIES SUPER CAB — GAS

Chassis Cab Code	Pick-Up Code	Basic Series
X17	X10	F100
X16	X14	F150 4x4
X19	X15	F150
X27	X25	F250
X28	X26	F250 4x4
X37	X35	F350

F-600 — CONVENTIONAL — GAS

Code	Basic Series
F60	F600
F61	F600
F65	F600 4x4
F66	F600 4x4

B-600 — COWL BUS — GAS

Code	Basic Series
B60	B600
B61	B600

F-700 — 7000 — CONVENTIONAL

Code	Basic Series
F70	F700 (Gas)
F82	F800 (Gas)
K70	F7000 (Diesel)
K71	F7000 (Diesel)

B-700 — 7000 BUS CHASSIS COWL

Code	Basic Series
B70	B700 (Gas)
B71	B700 (Gas)
J70	B7000 (Diesel)

P-600 — GAS

Code	Basic Series
P60	P600

L-SERIES — CONVENTIONAL

Code	Basic Series
L-Series — Diesel	
A90	LT-900 (LTL 9000 DSO)
L-Series — Gas	
F80, F81	L800
F90, F91	L900

L-SERIES — CONVENTIONAL (Cont'd)

Code	Basic Series
L-Series — Diesel	
K80	L8000
K81	L8000
K90	L9000
LT-Series — Gas	
T80, T81	LT800
T90, T91	LT900
LT-Series — Diesel	
U80, U81	LT8000
U90, U91	LT9000
LTS-Series — Gas	
V80, V81	LTS800
V90, V91, V92	LTS900
LTS-Series — Diesel	
Y80, Y81	LTS8000
Y90, Y91, Y92	LTS9000

N-SERIES — SHORT CONVENTIONAL

Code	Basic Series
N-Series — Gas	
N60	N600
N61, N62	N600
N70, N71	N700
N75, N76	N750
N80, N81	N800
N90, N91	N900
N-Series — Diesel	
R70, R71	N7000
R80, R81	N8000
R90	N9000
NT-Series — Gas	
S80, S81	NT800
S90, S91	NT900
NT-Series — Diesel	
W80, W81	NT8000
W90, W91	NT9000

C-SERIES — LOW TILT CABS

Code	Basic Series
C-Series — Gas	
C60	C600
C61	C600
C70	C700
C75	C750
C80	C800
C90, C91	C900
C-Series — Diesel	
D70	C7000
D80	C8000
CT-Series — Gas	
L80	CT800
L90, L91	CT900
CT-Series — Diesel	
Q80	CT8000

ENGINE CODES

ENGINE CODES

GAS ENGINE CODES—BRONCO

Code	Engine CID	Litre	Cyl.
H	351-2V	5.8L	8
S	400-2V	6.6L	8

GAS ENGINE CODES—LT. TRUCK (F-100 THRU F-350)

Code	Engine CID	Litre	Cyl.
B	300-1V	4.9L	6
G	302-2V	5.0L	8
Z	(DSO)		
H	351-2V	5.8L	8
S	400-2V	6.6L	8
J	460-4V	7.5L	8

GAS ENGINE CODES—MEDIUM TRUCK (F AND B-600)

Code	Engine CID	Litre	Cyl.
B	300-1V H.D.	4.9L	6
D	330-2V X.D.	5.4L	8
E	361-4V X.D.	5.9L	8
O	330-2V LPG (DSO)	5.4L	8
W	361-4V LPG (DSO)	5.9L	8
M	361-2V LPG (DSO)	5.9L	8
X	391-4V LPG (DSO)	6.4L	8
J	300-2V LPG (DSO)	4.9L	6
Z	(DSO)		

GAS ENGINE CODES—EXPORT LOW COMP.

Code	Engine CID	Litre	Cyl.
2	300-1V	4.9L	6
4	330-2V X.D.	5.4L	8
5	361-2V X.D.	5.9L	8
8	351-2V	5.8L	8

GAS ENGINE CODES—E-100 THRU E-350 (ECONOLINE AND CLUB WAGON)

Code	Engine CID	Litre	Cyl.
B	300-1V	4.9L	6
H	351-2V	5.8L	8
A	460-4V	7.5L	8
C	300-1V (3x6 Fuel Economy)	4.9L	6

GAS ENGINE CODES—700-900 SERIES AND N600-C600 PARCEL

Code	Low Comp. Code	Engine CID	Litre	Cyl.
G	—	300-1V H.D.	4.9L	6
D	4	330-2V H.D.	5.4L	8
E	—	361-4V H.D.	5.9L	8
F	—	361-4V H.D.	5.9L	8
J	—	475-4V	7.8L	8
K	—	477-4V S.D.	7.8L	8
L	—	534-4V S.D.	8.8L	8
Z	—	DSO		

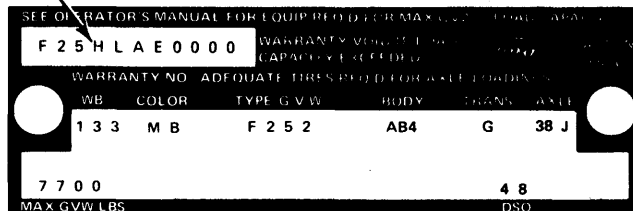

DIESEL ENGINE CODES — CATERPILLAR

CODE	CID	MODEL	H.P.	RPM
B	636	3208	175HP	2800
D	636	3208	210HP	2800
Q	636	3208	200HP	2800
H	893	3406	280HP	2100
J	893	3406 HT	280HP	1900
M	893	3406	325HP	2100
C		Special Order Caterpillar DSO		

DIESEL ENGINE CODES — CUMMINS

CODE	CID	MODEL	H.P.	RPM
1	855	NH230	230HP	2100
9	855	NTC230	230HP	2100
X	855	NTC230	230HP	1900
F	855	NTC250	250HP	2100
5	855	NTC250	250HP	1900
K	855	NTC270PT	270HP	2100
V	855	NTC290	290HP	2100
U	855	NTC290	290HP	1900
8	855	NTC350	320HP	2100
3	855	NTC350	320HP	1900
L	855	NTC350	350HP	2100
P	855	NTC350	350HP	1900
G	903	V903	295HP	2600
S		Special Order Cummins DSO		

DIESEL ENGINE CODES — DETROIT

Code	CID	Model	H.P.	RPM
1	318	6V-53TT	210HP	2500
0	318	6V-53TT	225HP	2500
2	426	671N	228HP	2100
7	568	8V71N	263HP	2100
6	568	8V71N	280HP	2100
T	568	8V71N	304HP	2100
N	568	8V71T	308HP	2100
E	568	8V71T	335HP	2100
Y	568	8V71T	350HP	2100
4	568	8V71TT	305HP	1950
A		Special Order Detroit DSO		
Z		Special Order DSO		
R		Delete Engine (Glider) DSO		

ASSEMBLY PLANT AND SEQUENTIAL SERIAL AND WARRANTY NUMBER CODES

ASSEMBLY PLANT CODES

Code	Assembly Plant
B	Oakville
C	Ontario Truck
E	Mahwah
H	Lorain
K	Kansas City
L	Michigan Truck
N	Norfolk
R	San Jose
S	Allen Park
U	Louisville
V	Kentucky Truck

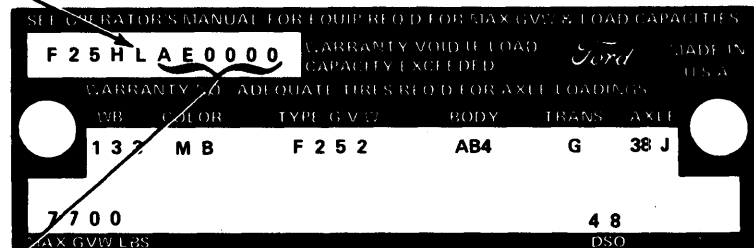

SEQUENTIAL SERIAL AND NUMBER WARRANTY NUMBER CODES
(1978 MODEL YEAR)

Bronco, LT Truck (F-100 Thru F-350)	
Code	Month and Year
AEO, 000 — AF9, 999	August, 1977*
AGO, 000 — AH9, 999	September, 1977
AJO, 000 — AK9, 999	October, 1977
BAO, 000 — BB9, 999	November, 1977
BCO, 000 — BD9, 999	December, 1977
BEO, 000 — BF9, 999	January, 1978
BGO, 000 — BH9, 999	February, 1978
BJO, 000 — BK9, 999	March, 1978
CAO, 000 — CB9, 999	April, 1978
CCO, 000 — CD9, 999	May, 1978
CEO, 000 — CF9, 999	June, 1978
CGO, 000 — CH9, 999	July, 1978
CJO, 000 — CK9, 999	August, 1978

F- and B-600 (Kentucky Truck Plant)	
Code	Month and Year
AEO, 000 — AE4, 999	August, 1977*
AGO, 000 — AG4, 999	September, 1977
AJO, 000 — AJ4, 999	October, 1977
BAO, 000 — BA4, 999	November, 1977
BCO, 000 — BC4, 999	December, 1977
BEO, 000 — BE4, 999	January, 1978
BGO, 000 — BG4, 999	February, 1978
BJO, 000 — BJ4, 999	March, 1978
CAO, 000 — CA4, 999	April, 1978
CCO, 000 — CC4, 999	May, 1978
CEO, 000 — CE4, 999	June, 1978
CGO, 000 — CG4, 999	July, 1978
CJO, 000 — CJ4, 999	August, 1978

E-100 Thru E-350 (Econoline and Club Wagon)	
Code	Month and Year
AEO, 000 — AF9, 999	August, 1977*
AGO, 000 — AH9, 999	September, 1977
AJO, 000 — AK9, 999	October, 1977
BAO, 000 — BB9, 999	November, 1977
BCO, 000 — BD9, 999	December, 1977
BEO, 000 — BF9, 999	January, 1978
BGO, 000 — BH9, 999	February, 1978
BJO, 000 — BK9, 999	March, 1978
CAO, 000 — CB9, 999	April, 1978
CCO, 000 — CD9, 999	May, 1978
CEO, 000 — CF9, 999	June, 1978
CGO, 000 — CH9, 999	July, 1978
CJO, 000 — CK9, 999	August, 1978

700Thru 9000 Series and N600 — C600 Parcel	
Code	Month and Year
AE5, 000 — AF9, 999	August, 1977*
AG5, 000 — AH9, 999	September, 1977
AJ5, 000 — AK9, 999	October, 1977
BA5, 000 — BB9, 999	November, 1977
BC5, 000 — BD9, 999	December, 1977
BE5, 000 — BF9, 999	January, 1978
BG5, 000 — BH9, 999	February, 1978
BJ5, 000 — BK9, 999	March, 1978
CA5, 000 — CB9, 999	April, 1978
CC5, 000 — CD9, 999	May, 1978
CE5, 000 — CF9, 999	June, 1978
CG5, 000 — CH9, 999	July, 1978
CJ5, 000 — CK9, 999	August, 1978

*Job #1—1978 Model Year

WHEEL BASE AND EXTERIOR PAINT CODES

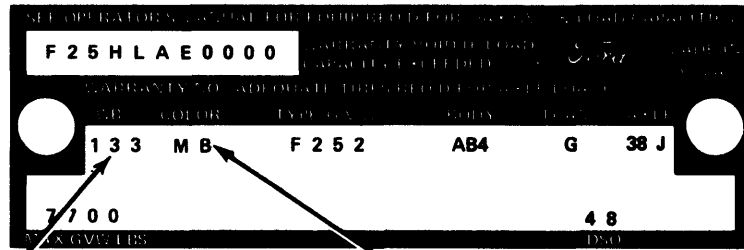

WHEEL BASE (IN INCHES)

Bronco			
104			
F-100 Thru F-350			
117	150		
133	155		
137	161		
139	167		
140			
F- and B-600			
134	182	212	
146	188	222	
156	194	242	
158	198	260	
176			
E-100 Thru E-350 (Econoline and Club Wagon)			
124			
138			
158			
700 Thru 9000 Series and N600— C600 Parcel			
099	146	167	203
111	148	174	204
124	150	175	206
134	153	176	212
135	154	184	220
136	155	185	222
137	158	186	236
138	161	188	242
143	162	194	250
144	166	202	260
			280

EXTERIOR PAINT COLOR CODE (2 CODES IF TWO TONED)

Refer To Volume 3 & 4, Group 30-00 For A Complete Listing of 1978 Truck Exterior Paint Codes.

TYPE/GVW AND MAX. G.V.W. CODES

SEE OPERATOR'S MANUAL FOR EQUIP REQ'D FOR MAX GVW & LOAD CAPACITIES

F 2 5 H L A E 0 0 0 0 WARRANTY VOID IF LOAD CAPACITY EXCEEDED *Ford* MADE IN U.S.A.

WARRANTY NO. ADEQUATE TIRES REQ'D FOR AXLE LOADINGS

WB	COLOR	TYPE	G.V.W.	BODY	TRANS	AXLE
1 3 3	M B	F 2 5 2		AB4	G	38 J

7 7 0 0 MAX GVW LBS 4 8 DSO

BRONCO		
Code	G.V.W.	
U150	6100	
U151	6400	
U152	6550	
U153	6010	

F-100 (4x2)		
Pickup Code	Chassis Cab Code	G.V.W.
F100	F170	4900
F101	F171	4800
F106	F176	5400
F107	F177	5600
F10N	F17N	5200

F-100 (4x2) Super Cab		
Pickup Code	Chassis Cab Code	G.V.W.
X108	X178	5700
X109	X179	5800
X10N	X17N	5200

F-150 (4x2)		
Pickup Code	Chassis Cab Code	G.V.W.
F150	F190	6050
F151	F191	6150

F150 (4x2) Super Cab		
Pickup Code	Chassis Cab Code	G.V.W.
X150	X190	6050
X152	X192	6200
X153	X193	6400

F-150 (4x4)		
Pickup Code	Chassis Cab Code	G.V.W.
F140	F160	6050
F141	F161	6300
F142	F162	6500

F-150 (4x4) SUPER CAB		
Pickup Code	Chassis Cab Code	G.V.W.
X143	X163	6400

F-250 (4x2)		
Pickup Code	Chassis Cab Code	G.V.W.
F250	F270	6200
F251	F271	6800
F252	F272	7700
F253	F273	7900

F-250 (4x2) SUPER CAB		
Pickup Code	Chassis Cab Code	G.V.W.
X251	X271	6800
X254	X274	6300
X255	X275	6550
X256	X276	7800
X257	X277	7050
X258	X278	7600
X259	X279	8100
X25N	X27N	7500

F-250 (4x4)		
Pickup Code	Chassis Cab Code	G.V.W.
F263	F283	6700
F264	F284	7300
F265	F285	8100
F266	F286	8400

F-250 (4x4) SUPER CAB		
Pickup Code	Chassis Cab Code	G.V.W.
X260	X280	7100
X261	X281	7600
X262	X282	8500

F-350 (4x2)		
Pickup Code	Chassis Cab Code	G.V.W.
F351	F371	6750
F351	F372	8000
F353	F373	8200
F353	F374	8300
F353	F375	8500
F353	F376	8900
F353	F377	9500
F353	F378	10,000
F354	F378	8300
F356	F378	8900
F359	F378	9900
F359	F37N	10,250
F359	F37P	9100

F-350 (4x2) SUPER CAB		
Pickup Code	Chassis Cab Code	G.V.W.
X359	X379	9200

F-600 (4x2)	
Code	G.V.W.
F600	16,000
F602	19,200
F603	14,000
F604	16,000
F605	17,400
F606	17,400
F611	20,200
F612	21,000
F613	22,000
F614	22,000
F615	23,000
F616	24,000
F618	17,900 U-Haul

F-600 (4x4)	
Code	G.V.W.
F650	17,200
F660	21,700
F661	24,000

B600 BUS (4x2)	
Code	G.V.W.
B600	17,400
B601	19,200
B602	19,200
B610	19,700
B611	20,200
B613	21,000
B615	22,000
B617	24,500
B618	22,160
B619	23,160

E-100 CLUB, CUSTOM, AND CHATEAU WAGONS	
Conv. Code	G.V.W.
E010	5500
E012	5900
E013	5700
E020	5900
E021	6000

E-150 CLUB, CUSTOM, AND CHATEAU WAGONS			
Conv. Code	Super Code	Conv. G.V.W.	Super G.V.W.
E112	S110	6200	6025
E113	S111	6400	6200
E114	S112	6500	6400
E120	S113	6300	6600
E123	S114	6500	6800
E124	S120	6700	6200
E124	S121	6700	6400
E124	S122	6700	6600
E124	S123	6700	6800

E-250 CLUB, CUSTOM, AND CHATEAU WAGONS			
Conv. Code	Super Code	Conv. G.V.W.	Super G.V.W.
E203	S200	7600	7600
E204	S201	7900	8000
E205	S202	8100	8300
E206	S203	8500	8500
E207	S204	8900	8500
E214	S210	6800	7000
E215	S211	7100	7200
E216	S212	7800	7400
E216	S213	7800	7700
E216	S214	7800	8000
E222	S220	8200	6900
E222	S221	8200	7200
E222	S222	8200	7400
E222	S223	8200	7700
E224	S224	6900	8000
E225	S225	7100	8300
E226	S226	7300	7700
E227	S227	7500	7700
E228	S228	7700	7700
E233	S230	7600	7600
E234	S231	7900	7800
E235	S232	8100	8000
E236	S233	8500	8300
E237	S234	8900	8500
E237	S290	8900	7000
E237	S291	8900	7900
E237	S292	8900	8100
E237	S293	8900	8200
E237	S294	8900	8300
E237	S295	8900	8400

E-350 CLUB, CUSTOM, AND CHATEAU WAGONS	
Code (Super)	G.V.W.
S300	8000
S301	8300
S302	8800
S303	9000
S304	9300
S320	7900
S321	8100
S322	8400
S323	8700
S324	9100
S330	8000
S331	8300
S332	8800
S333	9000
S334	9300
S390	8600
S391	8800
S392	9100
S393	9400

TYPE/GVW AND MAX. GVW CODES — CONTINUED

SEE OPERATOR'S MANUAL FOR EQUIPMENT AND MAX. GVW & LOAD CAPACITIES

F 2 5 H L A E 0 0 0 0 (WARRANTY VOID IF LOAD CAPACITY EXCEEDED)

WARRANTY NO. 20E0046 (THIS FIELD IS FOR AXLE LOADINGS)

SR COLOR TYPE GVW BODY TRANS AXLE

1 3 3 M B F 2 5 2 AB4 G 3 8 J

7 7 0 0 (MAX GVW LBS) 4 8 (GVW)

E-100 ECONOLINE CARGO, WINDOW, AND DISPLAY VANS

Conv. Cargo Code	Conv. Window Code	Conv. Display Code	G.V.W.
E040	E050	E060	5150
E041	E051	E061	5750

E-150 ECONOLINE CARGO, WINDOW, AND DISPLAY VANS

Conv. Cargo Code	Super Cargo Code	Conv. Window Code	Super Window Code	Conv. Display Code	Super Display Code	G.V.W. (Conv.)	G.V.W. (Super)
—	S140	—	S150	—	S160	—	6050
E141	—	E151	—	E161	—	6100	—
E142	—	E152	—	E162	—	6300	—

E-250 ECONOLINE CARGO, WINDOW, AND DISPLAY VANS

Conv. Cargo Code	Super Cargo Code	Conv. Window Code	Super Window Code	Conv. Display Code	Super Display Code	G.V.W. (Conv.)	G.V.W. (Super)
—	S240	—	S250	—	S260	—	6500
E241	S241	E251	S251	E261	S261	7550	7100
—	S242	—	S252	—	S262	—	7900
E243	—	E253	—	E263	—	6750	—
E244	—	E254	—	E264	—	8250	—

E-250 CUTAWAY VAN

Code	G.V.W.
E270	8400

E-250 CUTAWAY PARCEL DELIVERY VAN

Code	G.V.W.
E280	7700

E-350 ECONOLINE CARGO, WINDOW, AND DISPLAY VANS

Conv. Cargo Code	Super Cargo Code	Conv. Window Code	Super Window Code	Conv. Display Code	Super Display Code	G.V.W. (Conv.)	G.V.W. (Super)
—	S340	—	5350	—	S360	—	8100
—	S341	—	5351	—	S361	—	9100
—	S342	—	5352	—	S362	—	9400
E343	—	E353	—	E363	—	8550	—
E344	—	E354	—	E364	—	9500	—
E345	—	E355	—	E365	—	9800	—

E-350 CUTAWAY VAN

Code	G.V.W.
E370	8700 Single Rear
E371	9650 Single Rear
E372	8750 Dual Rear
E374	11,000 Dual Rear
E375	10,000 Dual Rear
E376	10,100 Dual Rear

E-350 CUTAWAY PARCEL DELIVERY VAN

Code	G.V.W.
E380	8750 Dual Rear
E382	10,000 Dual Rear
E383	10,500 Dual Rear
E384	9800 Dual Rear

TYPE/GVW AND MAX. G.V.W. CODES — CONTINUED

SEE OPERATOR'S MANUAL FOR EQUIP RECD FOR MAX GVW & LOAD CAPACITIES

F 2 5 H L A E 0 0 0 0 WARRANTY VOID IF LOAD CAPACITY EXCEEDED *Ford* MADE IN U.S.A.

WARRANTY NOT ADEQUATE TIRES RECD FOR AXLE LOADINGS

WB	COLOR	TYPE	G.V.W.	BODY	TRANS.	AXLE
1	3	M	B	F 2 5 2	AB4	G 38 J
7 7 0 0				4 8		
GVW LBS				DSO		

B-700 BUS CHASSIS COWL — GAS	
Code	G.V.W.
B702	23,160
B705	25,080
B706	24,500
B707	25,250
B708	27,080
B709	26,500
B710	27,250

B-7000 BUS CHASSIS COWL — DIESEL	
Code	G.V.W.
J707	26,500
J708	27,250
J709	27,080

F-700 — GAS	
Code	G.V.W.
F701	21,000
F703	23,000
F704	24,000
F706	25,500
F707	25,000
F708	27,000
F709	27,500

F-800 — GAS	
Code	G.V.W.
F820	23,000
F821	25,000
F822	25,500
F823	27,000
F824	27,500
F825	29,000
F826	31,000
F827	32,000

F-7000 — DIESEL	
Code	G.V.W.
K703	23,000
K705	24,000
K706	25,500
K707	27,500
K708	25,000
K709	27,000
K710	21,000

L-800 — GAS	
Code	G.V.W.
F800	23,000
F801	25,000
F803	25,500
F804	27,500
F805	29,000

L-800 — GAS (Cont'd)	
Code	G.V.W.
F806	31,000
F807	32,000
F808	34,000
F809	35,000
F811	31,800
F812	27,000

L-900 — GAS	
Code	G.V.W.
F900	25,500
F902	27,500
F905	31,000
F906	32,000
F908	34,000
F909	35,000
F912	23,000
F913	31,800

L-8000 — GAS	
Code	G.V.W.
K802	25,500
K803	27,000
K805	31,000
K806	32,000
K807	34,000
K808	35,000
K812	23,100
K813	31,800

L-9000 — GAS	
Code	G.V.W.
K902	32,000
K904	35,000
K907	28,000
K908	31,000

LT-800 — GAS	
Code	G.V.W.
T804	43,000
T806	46,000
T811	41,000
T812	44,800

LT-900 — GAS	
Code	G.V.W.
T900	39,000
T902	41,000
T904	43,000
T906	46,000
T907	50,000
T908	50,000
T909	54,000

LT-900 — GAS (Cont'd)	
Code	G.V.W.
T911	60,000
T914	44,800
T915	48,000
T916	52,000
T917	58,000

LT-8000 — DIESEL	
Code	G.V.W.
U800	39,000
U805	46,000
U806	50,000
U807	50,000
U808	54,000
U809	60,000
U810	55,000
U811	56,000
U812	62,000
U815	41,000
U816	44,800
U817	61,000

LT-9000 — DIESEL	
Code	G.V.W.
U900	43,000
U903	46,000
U904	50,000
U905	50,000
U906	54,000
U907	58,000
U908	60,000
U909	60,000
U910	62,000
U911	52,000
U912	62,000
U913	72,000
U914	44,800
U915	61,000
U916	48,000
U917	58,000
U918	74,000
U919	76,000

LTS-800 — GAS	
Code	G.V.W.
V804	46,000
V809	41,000
V810	44,000

LTS-900 — GAS	
Code	G.V.W.
V900	39,000
V904	46,000

LTS-900 — GAS (Cont'd)	
Code	G.V.W.
V905	50,000
V906	50,000
V907	52,000
V908	54,000
V909	56,000
V911	58,000
V912	60,000
V913	62,000
V914	64,000
V915	61,000
V918	41,000
V920	48,000

LT-9000 — GAS	
Code	G.V.W.
A900	44,800
A901	46,000
A902	48,000
A903	50,000
A904	50,000
A905	52,000
A906	54,000
A907	58,000
A908	60,000

LTS-9000 — GAS	
Code	G.V.W.
Y900	44,800
Y901	58,000
Y902	60,000
Y903	50,000
Y904	50,000
Y905	52,000
Y906	54,000
Y907	56,000
Y908	61,000
Y909	58,000
Y910	60,000
Y911	62,000
Y912	62,000
Y913	72,000
Y914	74,000
Y915	76,000
Y916	78,000
Y917	77,100
Y918	70,000
Y919	48,000
Y920	79,100
Y921	81,100

TYPE/GVW AND MAX. G. V. W. CODES — (CONTINUED)

SEE OPERATOR'S MANUAL FOR EQUIP. RECD. FOR MAX. GVW & LOAD CAPACITIES

F 2 5 H L A E 0 0 0

WARRANTY VOID IF LOAD CAPACITY EXCEEDED

WARRANTY NO. ADEQUATE TIRES RECD. FOR AXLE LOADINGS

WB: 1 3 3 COLOR: M B TYPE/GVW: F 2 5 2 BODY: AB4 TRANS: G AXLE: 38 J

7 7 0 0 4 8

MAX. GVW: LBS DSO

LTS-8000 — DIESEL	
Code	G.V.W.
Y800	39,000
Y804	46,000
Y805	50,000
Y806	50,000
Y807	52,000
Y808	54,000
Y812	60,000
Y814	64,000
Y815	55,000
Y816	56,000
Y817	61,000
Y818	41,000
Y819	62,000

N-800 — GAS	
Code	G.V.W.
N601	16,500
N602	19,500
N603	21,500
N612	23,000
N615	24,000
N620	22,000

N-700 — GAS	
Code	G.V.W.
N702	23,000
N703	25,500
N705	27,000
N706	27,500
N707	25,000
N710	21,000
N712	24,000

N-800 — GAS	
Code	G.V.W.
N800	23,000
N801	25,000
N803	25,500
N804	27,500
N805	29,000
N806	31,000
N807	27,000
N808	34,000
N813	31,800
N814	32,000
N815	35,000

N-900 — GAS	
Code	G.V.W.
N900	25,500
N902	27,500
N905	31,000
N906	32,000
N908	34,000
N909	35,000
N911	23,100
N912	31,800

N-7000 — GAS	
Code	G.V.W.
R702	23,000
R704	25,500
R705	25,000
R707	27,500
R708	27,000
R710	21,000
R712	24,000

N-8000 — GAS	
Code	G.V.W.
R802	25,500
R803	27,500
R805	31,000
R806	32,000
R807	34,000
R808	35,000
R810	23,100
R811	31,800

N-9000 — GAS	
Code	G.V.W.
R902	32,000
R904	35,000
R906	28,000
R907	31,800

NT-800 — GAS	
Code	G.V.W.
S804	43,000
S806	46,000
S811	41,000
S812	44,800

NT-900 — GAS	
Code	G.V.W.
S900	39,000
S902	41,000
S904	43,000
S906	46,000
S907	50,000
S909	54,000
S914	44,800
S915	48,000
S916	52,000

NT-8000 — DIESEL	
Code	G.V.W.
W800	39,000
W803	56,000
W804	62,000
W805	46,000
W806	50,000
W807	50,000
W808	54,000
W812	41,000
W814	44,800
W815	55,000
W816	60,000
W817	61,000

NT-9000 — DIESEL	
Code	G.V.W.
W903	46,000
W904	50,000
W906	54,000
W907	43,000
W910	58,000
W911	44,800
W912	48,000
W913	52,000
W914	60,000
W915	62,000
W916	72,000
W917	74,000
W918	76,000

P-800 — GAS	
Code	G.V.W.
P600	15,000
P603	12,000
P602	17,000
P605	17,000

C-600 — GAS	
Code	G.V.W.
C602	17,000
C612	23,000
C613	24,000
C617	21,200

C-700 — GAS	
Code	G.V.W.
C700	24,000
C701	25,000
C702	25,500
C703	27,000
C704	27,500
C705	21,000

C-800 — GAS	
Code	G.V.W.
C802	27,500
C803	31,000
C804	34,000
C807	25,100

C-900 — GAS	
Code	G.V.W.
C904	25,100
C906	31,000
C907	32,000
C910	34,000
C912	37,000
C914	25,100
C915	39,000

C-7000 — GAS	
Code	G.V.W.
D701	21,000
D702	25,500
D703	24,000
D704	25,000
D705	27,500
D706	27,000
D708	23,000

C-8000 — GAS	
Code	G.V.W.
D802	27,500
D806	25,100
D807	32,000
D808	35,000

CT-800 — GAS	
Code	G.V.W.
L801	42,860
L803	44,000
L805	45,000
L807	46,000
L808	48,000
L809	50,000

CT-900 — GAS	
Code	G.V.W.
L901	42,860
L902	44,000
L903	45,000
L914	46,000
L915	48,000
L916	50,000
L917	52,000
L918	54,000
L919	50,000

CT-9000 — DIESEL	
Code	G.V.W.
Q801	42,860
Q803	45,000
Q804	44,000
Q805	41,000
Q807	46,000
Q808	48,000
Q809	50,000

BODY AND TRANSMISSION CODES

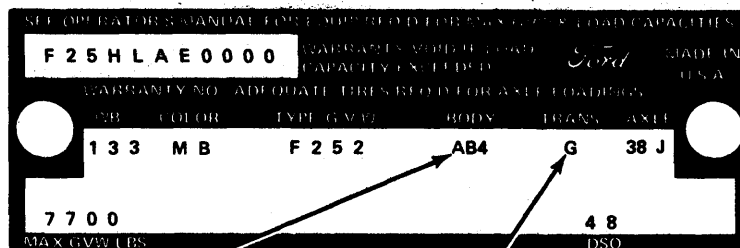

BODY CODES

Refer to Volume 3 & 4, Group 30-00 for a complete listing of 1978 Truck Body Codes.

TRANSMISSION CODES

Code	Description
Econoline — Club Wagon	
C	3-Speed Manual
G	Cruisomatic
B	Clark Manual 4-Speed Overdrive
Bronco — F-100-350	
G	Automatic
C	Ford Manual 3-Speed
F	Warner 4-Speed Manual
A	New Process 4-Speed Manual
B	Clark Manual 4-Speed Overdrive
F & B 600	
L	Allison AT540
P	Warner T-19 4-Speed
G	C-6 Automatic
4	Clark 280-V0 Overdrive 5-Speed
2	Clark 282-V Direct 5-Speed
M	Clark 285-V Direct 5-Speed
A	New Process 435 4-Speed
9	New Process 542-FD Direct 5-Speed
0	New Process 542-FL Direct 5-Speed

AUXILIARY TRANSMISSION

FORD HEAVY AND EXTRA-HEAVY TRUCK — PARCEL

Code	Description
4	Spicer 7231-D
7	Spicer R-8341-2
8	Spicer 7041

700 THRU 9000 SERIES AND N600-C600 PARCEL

Gas	Diesel	Description
L	—	Allison AT-540 Automatic
8	—	Allison MT-640 Automatic
H	H	Allison MT-650 Automatic
4	—	Clark 280 5-Speed
2	—	Clark 282 5-Speed
M	M	Clark 285 5-Speed
—	6	Clark 390 5-Speed
—	Z	Clark 397 5-Speed
I	—	Ford C-6 Automatic
C	C	Fuller RT-610 10-Speed
P	P	Fuller RT-613 13-Speed
—	X	Fuller T-905A 5-Speed
—	O	Fuller T-905B 5-Speed
—	3	Fuller RT-906 6-Speed
—	V	Fuller RT-910 10-Speed
—	5	Fuller RTO-910 10-Speed O/D
—	9	Fuller RTO-958LL 8-Speed
—	Q	Fuller RT-1110 10-Speed
—	8	Fuller RT-9509A 9-Speed
—	4	Fuller RT-9513 13-Speed
—	J	Fuller RTO-9513 13-Speed O/D
—	E	Fuller RT-12510 10-Speed
—	F	Fuller RTO-12513 10-Speed O/D
—	T	Fuller RTOF-12513 10-Speed
A	—	New Process NP-435 4-Speed
9	—	New Process NP-542-FD 5-Speed
0	—	New Process NP-542-FL 5-Speed
T	—	New Process NP-542-FO 5-Speed
—	G	Spicer SST-1007-2A 7-Speed
—	A	Spicer SST-1010 10-Speed
7	7	Spicer CM-5052A 5-Speed
D	D	Spicer CM-5252A 5-Speed
B	B	Spicer CM-6052A 5-Speed
K	K	Spicer CM-6052B 5-Speed
S	S	Spicer CM-6052C 5-Speed
—	Y	Spicer RP-85163-A 16-Speed
—	R	Delete Transmission (Glider)

AXLE CODES (REAR)

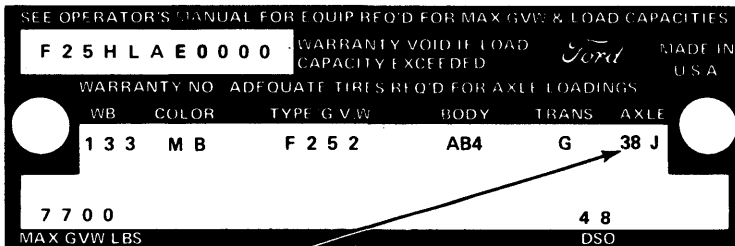

700 THRU 9000 SERIES AND N-600 — C-600 PARCEL

Code	Description	#Capacity	Ratio
KA	Rockwell R-170 w/Traction	23000	4.33
LA	Rockwell R-170 w/Traction	23000	5.29
MA	Rockwell R-170 w/Traction	23000	6.14
JF	Eaton 34-DSC	34000	4.11
BF	Eaton 34-DSC	34000	4.33
CF	Eaton 34-DSC	34000	4.56
DF	Eaton 34-DSC	34000	4.88
LF	Eaton 34-DSC	34000	3.70
FF	Eaton 34-DSC	34000	5.57
GF	Eaton 34-DSE	34000	6.14
HF	Eaton 34-DSE	34000	6.50
MF	Eaton 34-DSE	34000	7.17
KF	Eaton 34-DSE	34000	7.60
FN	Eaton 34-DPC	34000	7.60
FW	Eaton 34-DTE	34000	6.14/8.38
GW	Eaton 34-DTE	34000	6.50/8.87
HW	Eaton 34 DTE	34000	7.17/9.77
BC	Rockwell SLHD	34000	3.70
B1	Rockwell SLHD	34000	4.11
B2	Rockwell SLHD	34000	4.44
B6	Rockwell SLHD	34000	5.83
B7	Rockwell SLHD	34000	6.17
B8	Rockwell SLHD	34000	6.83
B9	Rockwell SLHD	34000	7.80
AJ	Eaton 38-DSC	38000	4.56
BJ	Eaton 38-DSC	38000	4.88
CJ	Eaton 38-DSC	38000	5.57
FJ	Eaton 38-DSC	38000	4.11
GJ	Eaton 38-DSC	38000	4.33
HJ	Eaton 38-DSC	38000	5.29
LJ	Eaton 38-DSC	38000	3.70
DJ	Eaton 38-DSE	38000	6.14
EJ	Eaton 38-DSE	38000	6.50
JJ	Eaton 38-DSE	38000	7.17
KJ	Eaton 38-DSE	38000	7.60
AR	Eaton 38-DPC	38000	5.05
ER	Eaton 38-DPC	38000	6.65
FR	Eaton 38-DPC	38000	7.60
TA	Rockwell SQHP	38000	3.70
TB	Rockwell SQHP	38000	4.11
TC	Rockwell SQHP	38000	4.44
TD	Rockwell SQHP	38000	4.63
TE	Rockwell SQHP	38000	4.88
TF	Rockwell SQHP	38000	5.29
TG	Rockwell SQHP	38000	5.83
TH	Rockwell SQHP	38000	6.17
TJ	Rockwell SQHP	38000	6.83
TK	Rockwell SQHP	38000	7.80
D1	Rockwell SQHD Hendrickson	38000	4.11
D2	Rockwell SQHD Hendrickson	38000	4.44
D3	Rockwell SQHD Hendrickson	38000	4.63
D4	Rockwell SQHD Hendrickson	38000	5.29
D5	Rockwell SQHD Hendrickson	38000	5.83
D6	Rockwell SQHD Hendrickson	38000	6.63
D7	Rockwell SQHD Hendrickson	38000	7.80
D8	Rockwell SQHD Hendrickson	38000	4.88
DA	Rockwell SQHD Hendrickson	38000	6.17
DB	Rockwell SQHD Hendrickson	38000	3.70
AV	Eaton 42-DPB	44000	7.60
DV	Eaton 42-DPB	44000	5.91
XB	Rockwell SRDD	44000	5.78
6Y	Rockwell SSSH	44000	3.90
1Y	Rockwell SSSH	44000	4.11
2Y	Rockwell SSSH	44000	4.33
5Y	Rockwell SSSH	44000	4.63
8Y	Rockwell SSSH	44000	4.88
4Y	Rockwell SSSH	44000	5.29
AX	Eaton 50-DP	50000	5.61
XK	Rockwell SHDD	58000	5.96
XS	Rockwell SFDD	65000	5.76
XT	Rockwell SFDD	65000	8.08

BRONCO AND F-100 THRU F-350

Code	Description	#Capacity	Ratio
12	Ford	2900	3.00
06	Ford	2900	2.75
14	Ford	3750	3.00
15	Ford	3750	3.25
16	Ford	3750	3.50
13	Ford	3750	2.75
H2	Ltd. Slip	3750	3.50
H9	Ltd. Slip	3750	4.11
H4	Ltd. Slip	3750	3.25
23	Dana 61	5300	3.31
22	Dana 61	5300	3.07
24	Dana 60	5300	4.10
37	Dana 60	5300	3.54
38	Dana 60	5300	3.73
B4	Dana 60 Limited Slip	5300	4.10
C7	Dana 60 Limited Slip	5300	3.54
C8	Dana 60 Limited Slip	5300	3.73
27	Dana 70	7400	4.10
28	Dana 70	7400	4.56
36	Dana 70	7400	3.73
D7	Dana 70 Limited Slip	7400	4.10

700 THRU 9000 SERIES AND N-600 — C-600 PARCEL

Code	Description	#Capacity	Ratio
43	Rockwell D-140	13000	5.29
41	Rockwell D-140	13000	5.83
42	Rockwell D-140	13000	6.20
44	Rockwell D-140	13000	6.80
62	Rockwell F-106	15000	6.20
64	Rockwell F-106	15000	6.80
66	Rockwell F-106	15000	7.20
F2	Eaton 15201	15000 2-Speed	5.83/8.12
F3	Eaton 15201	15000 2-Speed	6.33/8.81
52	Rockwell H-17	17500	5.83
53	Rockwell H-17	17500	6.17
54	Rockwell H-17	17500	6.83
55	Rockwell H-17	17500	7.17
E1	Eaton 16244	17500 2-Speed	5.57/7.57
E2	Eaton 16244	17500 2-Speed	6.17/8.58
E3	Eaton 16244	17500 2-Speed	6.50/9.04
E4	Eaton 16244	17500 2-Speed	4.88/6.78
EQ	Eaton 17121	18500	5.57
FQ	Eaton 17121	18500	6.14
GQ	Eaton 17121	18500	6.50
HQ	Eaton 17121	18500	7.17
JQ	Eaton 17121	18500	7.60
EH	Eaton 17221	18500 2-Speed	5.57/7.60
FH	Eaton 17221	18500 2-Speed	6.14/8.38
GH	Eaton 17221	18500 2-Speed	6.50/8.87
HH	Eaton 17221	18500 2-Speed	7.17/9.77
DK	Eaton 18121	22000	6.50
EK	Eaton 18121	22000	7.17
DB	Eaton 18221	22000 2-Speed	5.57/7.60
EB	Eaton 18221	22000 2-Speed	6.14/8.38
FB	Eaton 18221	22000 2-Speed	6.50/8.87
GB	Eaton 18221	22000 2-Speed	7.17/9.77
AG	Eaton 19121	23000	4.11
BG	Eaton 19121	23000	4.33
HG	Eaton 19121	23000	4.56
CG	Eaton 19121	23000	4.88
DG	Eaton 19121	23000	5.43
EG	Eaton 19121	23000	6.17
FG	Eaton 19121	23000	6.67
GG	Eaton 19121	23000	3.70
GG	Eaton 23121	23000	3.70
AG	Eaton 23121	23000	4.11
BG	Eaton 23121	23000	4.33
HG	Eaton 23121	23000	4.56
CG	Eaton 23121	23000	4.88
DG	Eaton 23121	23000	5.43
EG	Eaton 23121	23000	6.17
FG	Eaton 23121	23000	6.67
GP	Eaton 23221	23000 2-Speed	4.11/5.60
CP	Eaton 23221	23000 2-Speed	5.43/7.39
DP	Eaton 23221	23000 2-Speed	6.17/8.40
EP	Eaton 23221	23000 2-Speed	6.67/9.08
AP	Eaton 23221	23000 2-Speed	4.35/5.90
N1	Rockwell R-171	23000	4.11
N2	Rockwell R-171	23000	4.33
N3	Rockwell R-171	23000	4.63
N4	Rockwell R-171	23000	4.88
N5	Rockwell R-171	23000	5.29
N6	Rockwell R-171	23000	5.86
N7	Rockwell R-171	23000	6.14
1A	Rockwell R-170	23000	4.11
2A	Rockwell R-170	23000	4.33
3A	Rockwell R-170	23000	5.29
4A	Rockwell R-170	23000	6.14
7A	Rockwell R-170	23000	5.86
8A	Rockwell R-170	23000	3.70
JA	Rockwell R-170 w/Traction	23000	4.11

E-100 THRU E-350 (Non-Locking)

Code	Description	#Capacity	Ratio
01	Ford	2750	3.00
05	Ford	2750	2.75
13	Ford	3750	2.75
14	Ford	3750	3.00
16	Ford	3750	3.50
15	Ford	3750	3.25
22	Dana	5300	3.07
23	Dana	5300	3.31
38	Dana	5300	3.73
24	Dana	5300	4.10
36	Dana	7400	3.73
27	Dana	7400	4.10

E-100 THRU E-350 (Locking)

Code	Description	#Capacity	Ratio
H2	Ford	3750	3.50
H4	Ford	3750	3.25
H7	Ford	3750	3.00
C8	Dana	5300	3.73
D7	Dana	7400	4.10

F- AND B-600

Code	Description	#Capacity	Ratio
41	Rockwell D-140	13000	5.83
42	Rockwell D-140	13000	6.20
62	Rockwell F-106	15000	6.20
64	Rockwell F-106	15000	6.80
66	Rockwell F-106	15000	7.20
F2	Eaton 15201	15000 2-Speed	5.83/8.12
F3	Eaton 15201	15000 2-Speed	6.33/8.81
52	Rockwell H-172	17500	5.83
53	Rockwell H-172	17500	6.17
54	Rockwell H-172	17500	6.83
55	Rockwell H-172	17500	7.17
E1	Eaton 16244	17500 2-Speed	5.57/7.57
E2	Eaton 16244	17500 2-Speed	6.17/8.58
E3	Eaton 16244	17500 2-Speed	6.50/9.04

FRONT AXLE AND D.S.O. CODES

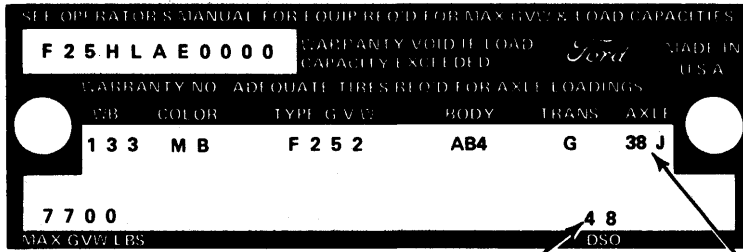

DISTRICT SALES OFFICE (DSO) CODE

DSO — FSO — PTO (DOMESTIC, FOREIGN AND SPECIAL ORDER)

The D.S.O. space will show a two digit code number of the district which ordered the unit (see chart below). This code will appear on all units — domestic or export. If unit is built on a D.S.O., E.S.O., P.T.O., (special orders) the complete order number is under the D.S.O. space after the district code.

FRONT AXLE CODES (Not Applicable On E-100 Thru E-350)

Bronco and F-100 Thru F-350				
Adjustable Steering Col. And Power Steering	With Power Steering	Code	Front Axle/ Power Steering	
—	J	—	Power Steering	
I	R	9	3800 #Dana-60F	
E	N	5	3550 #Dana 44-9F	
A	—	—	Adjustable Steering Col. and Power Steering	

F- and B-600				
P/Steering Delete	W/Power Steering	Code	Front Axle	
A	J	—	Power Steering	
—	K	2	5,500 STD, F-600	
—	L	3	6,000 STD, B-600	
D	M	4	7,000	
E	N	5	7,500	

700 THRU 9000 SERIES AND N-600 — C-600 PARCEL				
Axle Substitution	Power Steering	Axle Subst. and Power Steering	Delete Power or Manual Steering	Front Axle
V	K	A	2	5,500#
Y	J	Z	1	5,000#
C	L	W	3	6,000#
D	M	X	4	7,000#
E	N	O	5	9,000#
G	P	Q	7	12,000#
H	—	—	8	12,000# Steer Ease
—	S	B	—	16,000#
—	T	F	—	18,000#
—	U	I	—	20,000#
—	—	—	6	4,700#

DISTRICT CODES

11 Boston	41 Chigago	71 Los Angeles	Ford of Canada	
12 Buffalo	42 Cleveland	72 San Jose		
13 New York	43 Milwaukee	73 Salt Lake City	Mercury Regions	Ford Regions
14 Pittsburgh	45 Lansing	74 Seattle	A1 Central	B1 Central
15 Newark	46 Indianapolis	75 Phoenix	A2 Eastern	B2 Eastern
16 Philadelphia	47 Cincinnati	76 Denver	A3 Atlantic	B3 Atlantic
17 Washington	48 Detroit		A4 Midwestern	B4 Midwestern
21 Atlanta	52 Dallas	83 Government	A6 Western	B6 Western
22 Charlotte	53 Kansas City	84 Home Office Reserve	A7 Pacific	B7 Pacific
23 Memphis	54 Omaha	85 American Red Cross	12 Export	12 Export
24 Jacksonville	55 St. Louis	89 Transportation Services	Note: EXPORT ALPHABETICAL 1	
25 Richmond	56 Davenport	87 Body Company		
26 New Orleans	57 Houston			
28 Louisville	58 Twin Cities	90's Export		

WHEELS AND TIRES		GROUP 11 (1000 & 2000)
General Wheel and Tire Service	11-01	Wheel Hubs and Bearings —
Wheels and Tires —		Front (Except Front Drive)
Drop-Center Rim	11-02	Wheel Hubs and Bearings —
Wheels and Tires —		Front Wheel Drive
Three-Piece Rim	11-04	Wheel Hubs and Bearings Rear
Wheels and Tires —		(Semi Floating Axle)
Two-Piece Rim	11-03	Wheel Hubs and Bearings —
		Rear (Full Floating Axle)

General Wheel and Tire Service		PART 11-01	
APPLIES TO ALL MODELS			
SUBJECT	PAGE	SUBJECT	PAGE
SAFETY	01-2	Front Wheel Bearing Maintenance	01-10
DIAGNOSIS AND TESTING		Wheel and Tire Checking Procedure	01-8
Diagnosis Guides	01-3	ADJUSTMENTS (Cont'd.)	
ADJUSTMENTS		Wheel and Tire Vibration	
Balancing Wheels		Diagnosis Procedures	01-8
Dual Wheels and Wheels of Trucks		CLEANING AND INSPECTION	01-9
Equipped with Full Floating Axles	01-9	Aluminum Wheels & Rims	01-9
Rear Wheels of Trucks with		Front Wheel Bearings	01-9
Semi-Lock Differential	01-8	Rim & Wheel Maintenance	01-11
Single Rear Wheels F-100-F-350,		Safety Precautions	01-11
E-100-E-350, Bronco	01-8	Tires	01-9
		Wheels	01-9

SAFETY

When replacing tires, use the same size, load range and construction type (bias, bias belted or radial) as originally installed on your vehicle. When replacing wheels, use original equipment manufacturers wheels or equivalent available from your Ford dealer with equivalent capacity, width, offset and mounting configuration as those originally installed on your vehicle. Use of improper replacement wheels and tires may adversely affect ride, handling, load carrying capacity, bearing life, tire clearance to body and chassis components, vehicle ground clearance, vehicle width and brake cooling.

SAFETY PRECAUTIONS WHEN SERVICING TRUCK TIRES

CAUTION AND SAFETY FIRST are bywords when handling tires, particularly truck tires. Careful attention to the suggestions that follow may prevent crippling injuries, or even death. **Make it a rule to respect the terrific force contained in an inflated tire.** You may be glad some day that you did.

Prepare for any tire repair operation in a safe and efficient way. In changing tires on drop center wheels, remove the wheel and tire from the truck, as **changing tires with the wheel on the truck is hazardous, more difficult, and takes more time.** In servicing of all tires use caution not to drop them (or the wheels or assemblies) on the feet, hands or body, or heavily on the floor (Fig. 1). Practice good methods of lifting; use your legs as well as your arms and your body. This will help to prevent painful, internal injury. When carrying tires or wheels don't step in oil or grease. **Keep the floor clean and dry.**

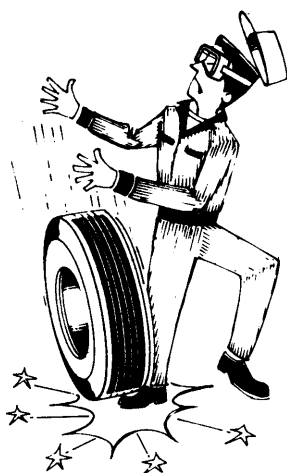

F1857-B

FIG. 1 Handling Wheels and Tires

Deflating a tire properly is very important to your safety. First, reduce

the pressure as much as you possibly can by pushing the valve core plunger. **Only then should you remove the valve core.** Keep your eyes away from the valve: Fig. 2 shows the safe way to do it.



F1853-B

FIG. 2 Safe Air Removal

Demounting tires from wheels or rims requires special care. Tires on drop center rims are best handled on a wheel holder, or tire-changing machine (Fig. 3).

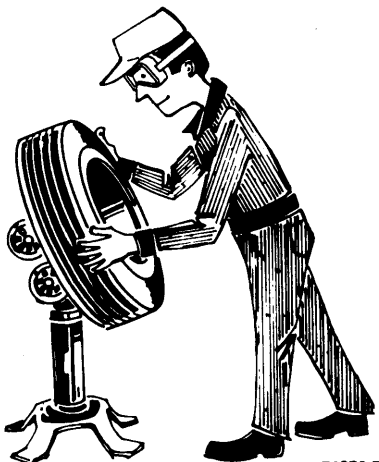

F1856-B

FIG. 3 Changing Tire on Drop Center Rim

This can help prevent cuts on hands and wrists and will make it unnecessary to use a mallet for seating the tire.

Use only standard tire mounting tools and equipment. The use of makeshift tools, screwdrivers or pliers to force tires on or off rims or wheels is dangerous.

Always lubricate tire beads to assure sealing of tire beads on rim with rubber lubricant ESA-M1B6-A, or equivalent.

The Rotunda tire changer includes a bead seater/inflator using an automatically adjustable inflation ring, which aids in properly seating the bead for inflation. To properly operate the Rotunda tire changer, follow the instructions provided.

As with the drop-center rims, be certain on split-rim assemblies that all air is out before unlocking a rim or ring. **Use special care when using tire irons.** Grip them firmly and keep them free of oil and grease. They can slip and fly with tremendous force (Fig. 4).



F1858-B

FIG. 4 Use of Tire Irons

A careful inspection should be made of the tire and all necessary repairs should be performed. A tire spreader is very helpful (Fig. 5) but use care when working around it. Keep the spreader arms closed when the machine is idle.

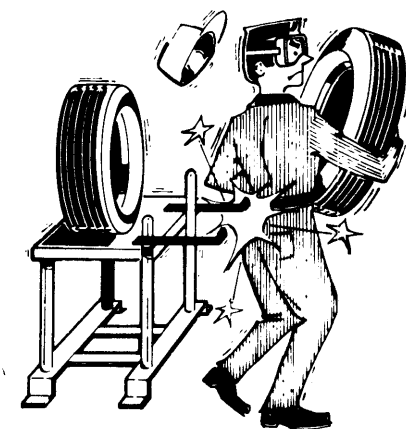

F1860-B

FIG. 5 Tire Spreader

Inspect the rim parts carefully for rust, damage or distortion (Fig. 6). Never use rims, locking rings or flanges which are out of shape, rusted or cracked or broken in any way. **Never use a ring or other rim parts of different manufacture than the original rims or any different size or type.**

Tires and rims often require a buffing operation before being mounted once the regular repairs have been made.

Always wear Safety Goggles, or a face shield when performing any buffing operation.

Avoid hammering rings or rims with steel hammers. Small bits of steel may be broken off the hammer or rim, flying into the eyes (wear safety goggles) face or

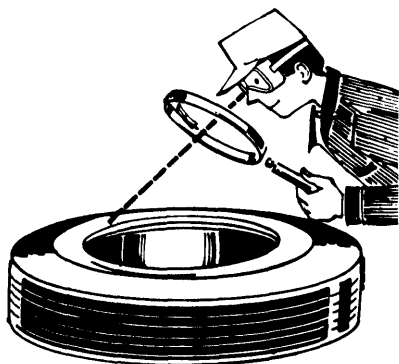

F1854-B

FIG. 6 Visual Inspection

body. Use rubber-covered, steel-headed hammers wherever possible (Fig. 7). Rubber mallets only should be used on passenger car tires; although with modern tire changing equipment no pounding is necessary.

Make certain the rim ring is seated to full depth of the groove, fits tightly all around, and is securely locked.

Stand away from the valve stem as far as possible while inflating tires. Avoid a



F1859-B

FIG. 7 Seating of Rings

position where the face or body is immediately over the work being done on any tire in which there is pressure.

Attach a portable safety device, made especially for the purpose, to the assembly. This portable device should be used with all types of wheels and rims.

If the assembly is not of the type which requires inflation to seat the rings, a **Safety Cage** should be used, although the portable device is the best (Fig. 8).



F1855-B

FIG. 8 Inflation Details

Use only accurate, tested gauges to insure proper air pressure. Check all gauges regularly with a master gauge.

Play it **SAFE**. Set a good example for others who work with you. Follow the above suggestions completely. **If you are ever tempted to take a short cut because you are in a hurry, that is the time that you could get hurt.**

Finally, always remember, a jack is provided for wheel and tire maintenance only. **Never run the engine when the vehicle is supported by a jack.**

DIAGNOSIS AND TESTING

DIAGNOSIS GUIDES

The following guides can be used as an aid in wheel and tire service diagnosis.

PROBLEM	POSSIBLE CAUSE	CORRECTION
<ul style="list-style-type: none"> • Tires show excess wear on edges of tread 	<ul style="list-style-type: none"> • Underinflated tires • Vehicle overloaded • High speed cornering • Incorrect toe setting 	<ul style="list-style-type: none"> • Adjust air pressure in tires • Correct as required • Correct as required • Set toe to specifications
<ul style="list-style-type: none"> • Tires show excess wear in center of tread • Excessive tire wear problems 	<ul style="list-style-type: none"> • Tires overinflated • Improper tire pressure • Incorrect tire/wheel usage • Loose or leaking shock absorbers • Front wheels out of alignment • Front wheel bearings out of adjustment • Loose, worn or damaged steering linkage or joints • Loose, worn or damaged suspension components, bushings and ball joints • Wheels and tires out of balance • Excessive lateral and/or radial runout of wheels and tires 	<ul style="list-style-type: none"> • Adjust air pressure in tires • Adjust air pressure in tires • Install correct tire/wheel combination • Tighten or replace as necessary • Align front wheels • Adjust front wheel bearings • Inspect, repair or replace as required • Inspect, repair or replace as required • Balance wheels and tires • Check, repair or replace as required

COMPLAINT	POSSIBLE CAUSE	CORRECTION
<p>Demountable Rims Driver reports excessive vehicle vibration rough steering and excessive fatigue. Related maintenance complaints include excessive vibration damage and repair costs plus severe tire wear</p>	<ul style="list-style-type: none"> • Improper procedures in mounting the rim to the cast wheel. Failure to follow proper torquing sequences and recommended foot pounds of torque results in "rim chording" where the rim clamps exert pressure as they are tightened which forces the rim out of round forming flat sides on the rim. • Improper positioning of side ring's split in relation to the rim's valve opening and welded drivers. • Out of balance rim and/or cast wheel, tire or hub and drum assembly. • Out of round rim (excessive radial runout). 	<ul style="list-style-type: none"> • Replace chorded rims. Check shop practices and tools to be sure manufacturer's recommendations on torque foot pounds and procedures are followed. • Reassemble with the ring split opposite (180°) the rim's valve opening and welded drivers to improve balance. • Determine out of balance component and balance or replace. • Replace the rim and check the following: <ul style="list-style-type: none"> — For proper handling of rim prior to use: — For overloading and unbalanced loads. — For road hazards and rugged operating conditions. — For proper rim specifications. — For proper mounting.
<p>Disc Wheels</p>	<ul style="list-style-type: none"> • Dirt and rocks wedged between disc and rim. • Out of balance wheel and/or tire or hub and drum assembly. • Improper positioning of the side ring's split. • Out of round wheel (excessive radial runout). 	<ul style="list-style-type: none"> • Clean and recommend the advantages of gutter mount design. • Determine the out of balance component and balance or replace. • Reassemble with the ring split opposite (180°) the valve opening to improve balance. • Replace the wheel and check for: overhauling and unbalanced loads. Road hazards and rugged operating conditions. Proper wheel specifications.
<p>Vehicle</p>	<ul style="list-style-type: none"> • Loose or worn drive line or suspension parts. 	<ul style="list-style-type: none"> • Identify location of vibration carefully as it may be transmitted through frame making a rear end vibration appear to come from the front. Then repair or replace loose and worn parts.
<p>Drivers report excessive vehicle vibrations rough steering, excessive fatigue, severe tire wear and road malfunctions.</p>	<ul style="list-style-type: none"> • Excessive lateral runout. • Loose or improper attaching parts • Worn or distorted spacers. • Overloading or unbalanced loads. • Road hazards (curb and rock impacts, etc.). • Improperly installed rim. 	<ul style="list-style-type: none"> • Check mounting. If proper, replace the rim. • Tighten or replace. • Replace. • Check rim specs against work load requirements with tire engineer, recommend correct tire and rim. Check on loading procedures. • Check operating conditions with tire engineer for possible change to heavier duty tire and rim. • Recommend that clamp nuts be retorqued after a 50-100 mile seating in period of the rim assembly to the wheel.
<p>Disc Wheels</p>	<ul style="list-style-type: none"> • Excessive lateral runout. • Bent or distorted disc from overloading road impact hazards or improper handling. • Loose mountings — Damaged studs, cap-nuts, enlarged stud holes, worn or broken hub face, or foreign material on mounting surfaces. 	<ul style="list-style-type: none"> • Replace wheel. • Replace wheel. Attempts to straighten wheel can result in fractures in the steel and weakening of the disc or the weld between disc and rim. Check loading and operating conditions, and shop practices. • Tighten and/or replace worn or damaged parts. Clean mounting surfaces.
<p>Vehicle</p>	<ul style="list-style-type: none"> • Improper alignment. • Loose, worn or broken suspension parts. 	<ul style="list-style-type: none"> • Have vehicle aligned. • Repair or replace.

COMPLAINT	POSSIBLE CAUSE	CORRECTION
Cracks develop in rim base, back flange or the gutter area	<ul style="list-style-type: none"> • Overloading or road hazards. • Improper use of tools. 	<ul style="list-style-type: none"> • Replace rim or wheel. Check loading and operating conditions. Avoid over inflation of tires. Check specs for rim load capacity, working loads, tire size, ply rating and tire construction. • Check mounting, demounting and maintenance procedures.
Demountable or Wheel Rims Side rings fail to hold properly, and are cracked or sprung on inspection	<ul style="list-style-type: none"> • Improper side and/or lock ring for wheel involved. • Improper mounting and demounting techniques. • Overloading, overinflation, road hazards. 	<ul style="list-style-type: none"> • Recommend proper side and/or lock rings for rim. • Replace damaged rings. Check and recommend proper procedures. • Check operating conditions and recommend right specifications.
Cracked or Broken Wheel Discs Cracks develop in the wheel disc from hand hole to hand hole, from hand hole to rim, or from hand hole to stud. Stud holes become worn, elongated or deformed, metal builds up around stud hole edges, cracks develop from stud hole to stud hole. Related driver complaints; unusual operating noise or vibration, and on the road failures	<ul style="list-style-type: none"> • Metal fatigue resulting from overloading and/or road hazards. • Truck operated with loose wheel mounting. 	<ul style="list-style-type: none"> • Replace wheel. Check position of wheel on vehicle for working load specifications. • Replace wheel and check for: <ul style="list-style-type: none"> — Installation of correct studs and nuts, and recommend exact specifications. — Cracked or broken studs, and replace. — Worn hub face machine if not excessive, or replace if severe. — Broken or cracked hub barrel replace. — Worn stud grooves replace or install recommended serrated bolts. — Clean mounting surfaces and re-torque cap nuts periodically. — Rust streaks fanning out from stud holes are a sure indication that the cap nuts are, or have been loose.
Demountable or Wheel Rims Decreased strength because of excessive rust or corrosion, bead seating problems, or loss of pressure with tubeless tires.	<ul style="list-style-type: none"> • Adverse storage or operating conditions. • Poor maintenance practices. 	<ul style="list-style-type: none"> • Recommend Goodyear Motor Wheel protective finish, or equivalent. • Recommend correct cleaning and protective procedures.
Wheel Disc	<ul style="list-style-type: none"> • Poor maintenance. 	<ul style="list-style-type: none"> • Keep clean and protected with paint.
Demountable or Wheel Rims Related maintenance complaints on tire damage included erratic or spotty wear, tire slippage, ply separation, excessive flexing, bead chafing, tube pinching, valve stem tearouts	<ul style="list-style-type: none"> • Wrong rim selection. • Rims of different size in dual mountings. • Improper inflation. • Severe hop and wobble. 	<ul style="list-style-type: none"> • Match rims and tires to working loads and operating conditions. • Match rim size before mounting duals. Detachable side and lock rings should also be matched correctly. • Follow specifications. • Follow recommendations under "Hop" and "Wobble."
Wheel Disc	<ul style="list-style-type: none"> • Rim flexing. • Bent or distorted disc. • Other conditions. 	<ul style="list-style-type: none"> • Recommend gutter mounted design. • See Disc Wheels under "Wobble." • See "Tire Mounting Difficulties," "Rim Mounting Difficulties," and "Wheel Mounting Difficulties."
Demountable or Wheel Rims Maintenance reports tire mounting problems, and drivers may report on road tire mounting failures	<ul style="list-style-type: none"> • Mismatched tire and rim sizes. • Defective or mismatched rings for rim used. • Overinflation of tires. • Corrosion and dirt. 	<ul style="list-style-type: none"> • Follow specifications. • Follow specifications. • Follow recommended tire pressures. • See "Corrosion."
Demountable Rims Maintenance reports rim mounting problems	<ul style="list-style-type: none"> • Improper application or mismatched parts, including spacer and clamps. • Corroded or worn parts. 	<ul style="list-style-type: none"> • Follow manufacturer's specifications. Check specs when chains, V-Belt drives, or special load tires are involved. • Clean or replace.
Disc Wheels Wheel mounting problems is the complaint	<ul style="list-style-type: none"> • Improper application or mismatched parts, including studs and nuts. • Corroded or worn parts. 	<ul style="list-style-type: none"> • Follow manufacturer's specifications. Check specs for disc and spacing when chains, V belt drives, or special load tires are involved. • Clean or replace.

COMPLAINT	POSSIBLE CAUSE	CORRECTION
Dual Tires Rubbing (kissing)	<ul style="list-style-type: none"> Insufficient Wheel Spacing. 	<ul style="list-style-type: none"> Check tire and wheel sizes — Make certain proper size tire and wheels are used.
Damage Stud Threads	<ul style="list-style-type: none"> Sliding wheel across studs during assembly. 	<ul style="list-style-type: none"> Replace studs. Follow proper wheel installation procedures.
Loose Drum	<ul style="list-style-type: none"> Stud too long. 	<ul style="list-style-type: none"> Replace stud with proper length stud.
Loose inner wheel	<ul style="list-style-type: none"> Excessive stud standout from mounting face of hub permitting wheel nut to bottom out. 	<ul style="list-style-type: none"> Replace stud with proper length stud.
Broken Studs	<ul style="list-style-type: none"> Loose Cap nuts. Overloading. 	<ul style="list-style-type: none"> Replace studs. Follow proper torque procedure. Replace studs. Compare actual load against wheel load ratings.
Stripped threads	<ul style="list-style-type: none"> Excessive torque. 	<ul style="list-style-type: none"> Replace Studs. Follow proper torque procedure.
Rust streaks from stud holes	<ul style="list-style-type: none"> Loose Cap Nuts. 	<ul style="list-style-type: none"> Check complete assembly. Replace damaged parts. Follow proper torque procedure.
Damaged inner or outer cap nuts	<ul style="list-style-type: none"> Loose wheel assembly. 	<ul style="list-style-type: none"> Replace cap nuts. Check for proper stud nuts standout. Follow proper torque procedure.
Frozen inner or outer cap nuts	<ul style="list-style-type: none"> Corrosion or galling. 	<ul style="list-style-type: none"> If corrosion is slight, wire brush away corrosion. If corrosion is excessive, replace studs and nuts. If condition persists, lubricate first three threads of each stud with a graphite-based lubricant. <p>CAUTION: Do not permit lubricant to get on ball seats of stud holes or on ball face of cap nuts.</p>

CF2602-2A3

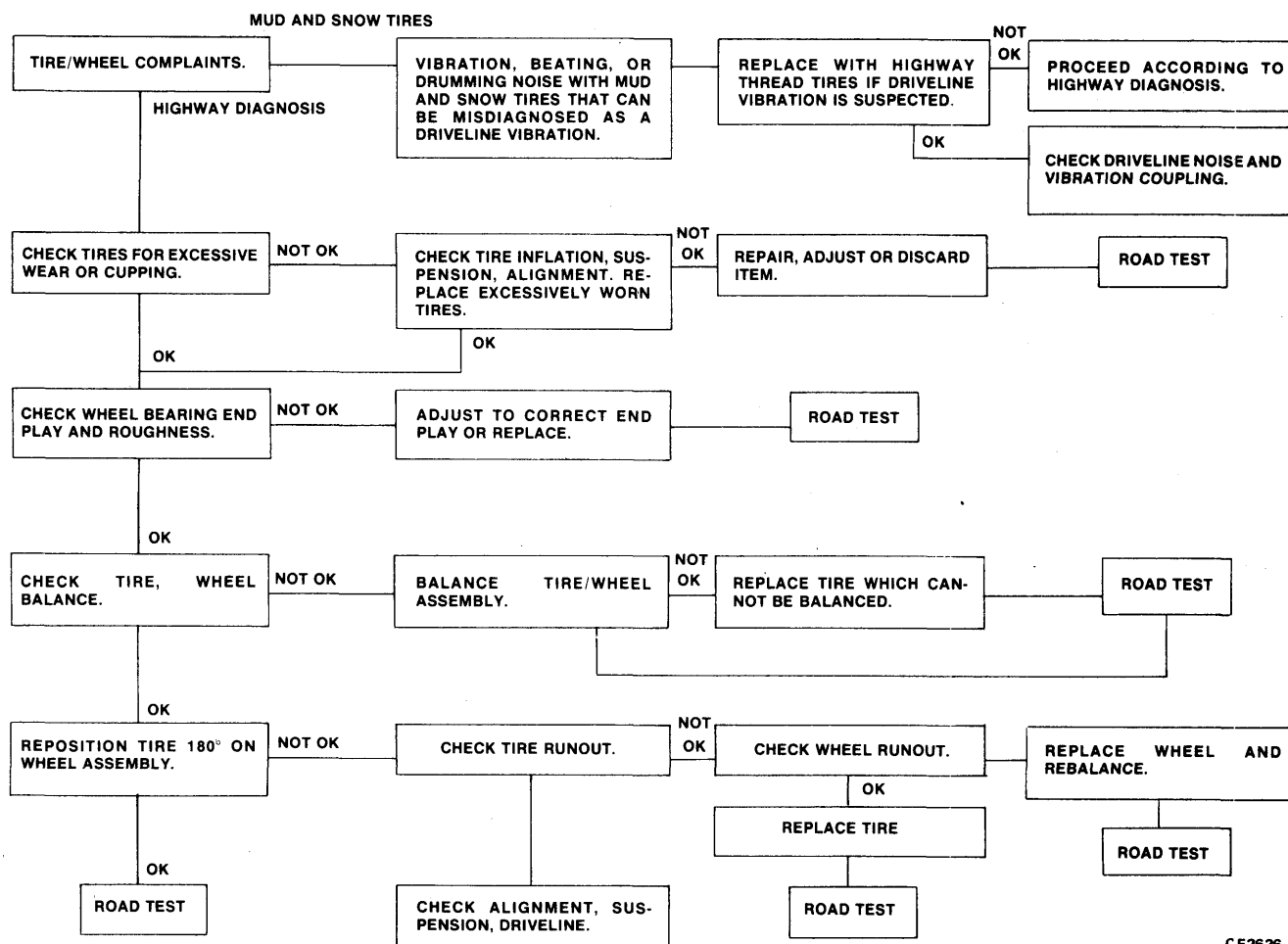

CF2626-A

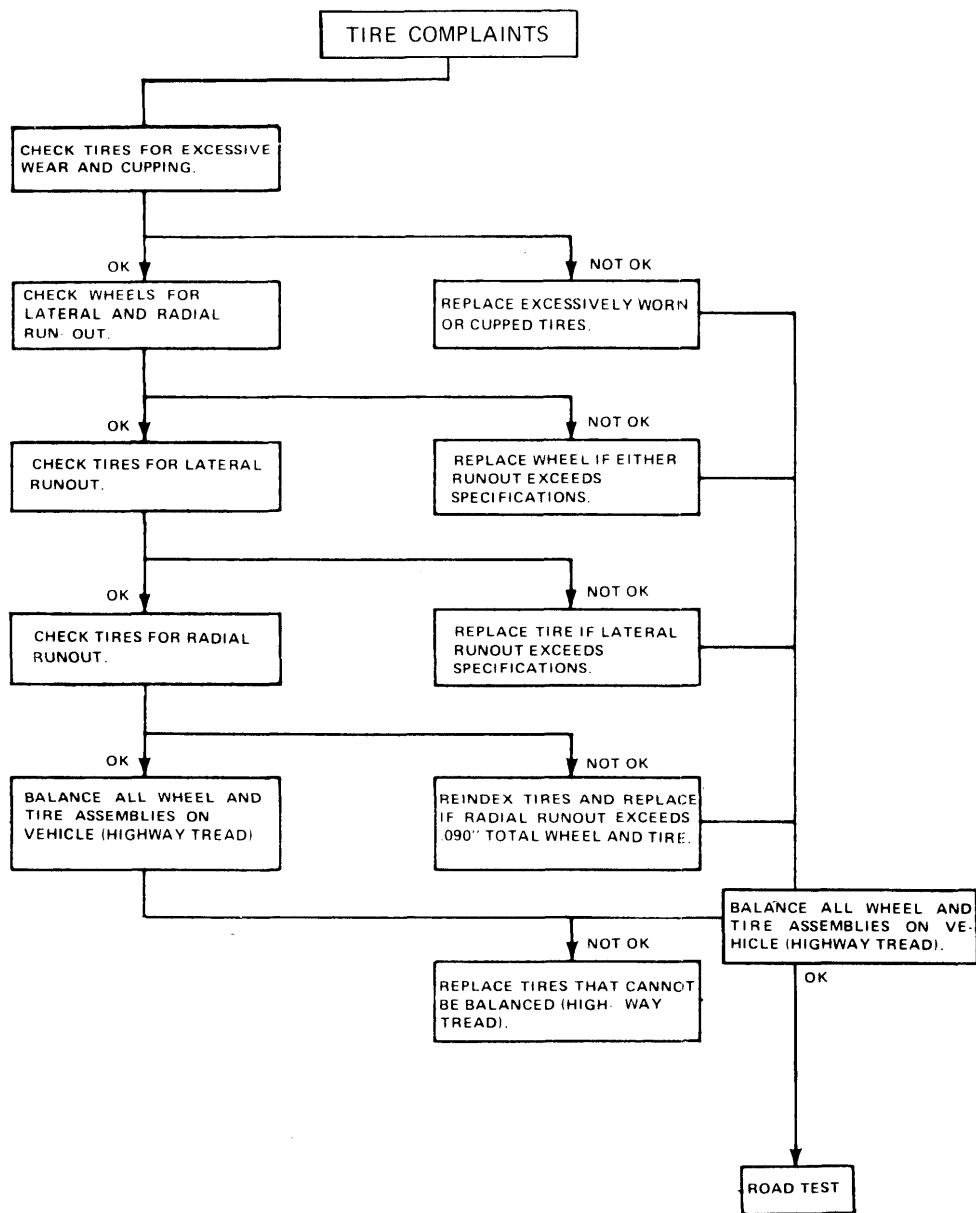

ADJUSTMENTS

WHEEL AND TIRE CHECKING PROCEDURE

Inspect tires for wear from incorrect mounting misalignment, loose wheel bearings, bent wheels, or cupping or scalping from imbalance. Tires which show irregularities and definite roughness must be replaced.

See the instructions provided with the Rotunda Wheel Balancer.

Make certain that the brakes are not dragging and wheel bearings are properly adjusted before attempting to spin the wheels. On vehicles equipped with disc brakes, push the brake shoes into the caliper to free the rotor.

WHEEL AND TIRE VIBRATION DIAGNOSIS PROCEDURES

NOTE: Mud and snow type tire vibration can often be mistaken for driveline problems, especially when mud and snow type tires are used on all wheels on four wheel drive vehicles.

- Road test vehicle to verify complaint. As soon as possible after the road test, raise vehicle on a hoist to prevent tire flat spotting. Check tires for excessive wear, inflation pressure or cupping. Check for alignment, or suspension problems that are indicated by the tire wear patterns.
- Spin front tires by hand to check bearing roughness. Replace worn bearings.
- Check for visible wheel or tire wobble. Replace as required.
- Check tire and wheel balance. Correct as necessary. Balance wheels by either static and dynamic wheel balance. Refer to section on "Balancing Wheels".
- If problem still exists, check both the radial runout and lateral runout of the tire as shown in Fig. 9.
- If radial runout is more than .090 inch, perform one of the following:
 - Reposition the tire 180 degrees on the wheel.
 - Find the highest point of tire radial runout. Mark this point on the tire. Find lowest point of radial runout on the wheel. Mark this point on the wheel. Demount the tire. Align the high point of the tire, with the low point on the wheel. Remount the tire. Recheck radial runout. If tire radial runout is still more than .090 inch, check the wheel. If radial runout is less than .070 inch, replace the tire. If the wheel is more than .070, replace the wheel. Rebalance the reworked assembly.

- If lateral runout is more than .090 inch, measure the wheel lateral runout (Fig. 9). If lateral runout is less than .070 inch, replace the tire. If total lateral runout is more than .070 inch, replace the wheel. After replacing, check runout again.

NOTE:

- When remounting the tire on the wheel, use ample tire mounting lubricant, ESA-M1B6, or equivalent, on the tire and wheel bead seat area. Inflate tires to 45 psi for passenger

wheel. Make sure the jack is secure and safe.

Spin the wheel with the engine and transmission in high gear at 30—40 mph on the speedometer. Do not spin powered wheels with a wheel spinner. Start the wheel as gradually as possible. Take care to avoid jerking condition on trucks equipped with an automatic shift. Use an accelerator pedal prop on vehicles not equipped with a hand throttle.

To balance, place the pick-up as close to the wheel as possible; then, with the

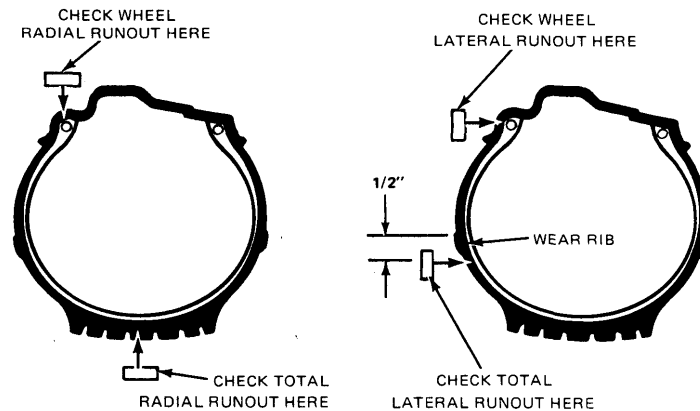

F2457-A

FIG. 9 Correct Placement of Runout Indicator Pickup

car type tires, or 80 psi for truck type tires to insure proper bead seating. Bleed tires to specified inflation pressure.

- If wheel and tire assembly is still not in balance after using on-the-vehicle balancer, or dynamic balance machine, the problem could be unbalanced brake drums. With vehicle raised on a hoist, remove the tire and wheel assembly. Place the wheel lug nuts on the wheel studs. Engage the transmission and drive the rear wheels to 30-50 mph (48-80km). If vehicle vibrates, perform static and dynamic balance on the drums by welding metal weights on the drum. Reinstall the wheel and tire assembly. Recheck balance and correct if necessary. Road test for final results.

BALANCING WHEELS

Single Rear Wheels F-100-350, E100-350, BRONCO

Don't use the spinner on any single rear wheels.

Jack up one rear wheel at a time, locate the jack securely under the frame, approximately one-foot ahead of the rear

wheel spinning at the speed where the maximum vibration is showing, read the strobe and follow the same procedure as balancing front wheels.

Rear Wheels of Truck with Semi-lock Differential

Use one of the following methods for rear wheels:

- Place a jack under the frame, one foot ahead of the rear wheel you want to balance. Jack up the wheel. Place another jack under the axle near the opposite rear wheel, and raise the wheel. Place the pick-up under the wheel. Spin the wheel with the motor to approximately 60—70 mph, to where the most vibration shows. Read the strobe and follow the same procedure required for balancing front wheels.
- Jack up the rear wheels as noted in step 1. Remove the rear wheel opposite the wheel you are to balance. Balance the rear wheel on the vehicle and reinstall the other wheel. After reversing the position of the jacks, balance the opposite rear wheel. Do not remove the first rear wheel.

Dual Wheels and Wheels of Trucks Equipped with Full-Floating Axles

Jack up the rear wheels with the jack located securely under the differential housing. Raise the wheels 1-1/2 inches from the floor.

Disconnect the wheel from the axle drive by removing the hub flange nuts or

screws. Pull the hub flange out to clear the studs at least 1/2 inch.

Spin Dual Wheels with an 800-C2 or 500-C Heavy-Duty Truck Spinner or equivalent.

FRONT WHEEL BEARING MAINTENANCE

Wheel bearings are adjustable. Satisfactory operation and long life of

bearings depend on proper adjustment and correct lubrication. **If bearings are adjusted too tightly, they will overheat and wear rapidly. An adjustment that is excessively loose can cause pounding and contribute to uneven tire wear, steering difficulties and inefficient brakes. The bearing adjustment should be checked at regular inspection intervals.**

CLEANING AND INSPECTION

WHEELS

Wheel stud nuts should be inspected and tightened twice within the first 500 miles of operation. After the first 1000 miles of operation, they should again be inspected and tightened. Loose wheel stud nuts may cause shimmy stud damage and/or failure, possible wheel damage, and vibration. Elongated stud holes in the wheels may also result from the loose stud nuts.

Keep the wheels and hubs clean. Stones or lumps of mud wedged between the wheel and drum will unbalance a wheel and tire.

Check for damage that would affect the runout of the wheels. Wobble or shimmy caused by a damaged wheel will eventually damage the wheel bearings and cause uneven tire wear. Inspect the wheel rims for dents that could permit air to leak from the tires.

TIRES

The tires should be checked frequently to be sure that the air pressures agree with those specified for the tires and vehicle model. Inspect the tire tread, and remove all stones, nails, glass or other objects that may be wedged in the tread. Check for holes or cuts that may permit air leakage from the tire, and make the necessary repairs.

Inspect the tire side walls for cuts, bruises, and other damage. If internal damage is suspected, demount the tire from the wheel for further inspection, repair or replacement.

Check the tire valve for air leaks, and replace the valve if necessary. Replace any missing valve caps.

On F-100-350, E-100-350, BRONCO it is important that all wheels be balanced. Fig. 10 describes common tire wear conditions.

FRONT WHEEL BEARINGS

Wheel bearings are adjustable, to correct for bearing and shoulder wear of the spindle. Satisfactory operation and long life of bearings depend on proper adjustment and correct lubrication. **If bearings are adjusted too tightly, they**

will overheat and wear rapidly. An adjustment that is excessively loose can cause pounding and contribute to uneven tire wear, steering difficulties and inefficient brakes. The bearing adjustment should be checked at regular inspection intervals.

Front hub assemblies and bearings should be cleaned, inspected and lubricated whenever the hub assemblies are removed or at the mileage/time periods indicated in the maintenance schedule.

New hub assembly grease seals should be installed when the hub is removed. A damaged or worn seal may permit bearing lubricant to reach the brake linings, resulting in ineffective brake operation and necessitating premature replacement of linings.

Bearing adjustment is described in Part 11-10 for front wheels. Part 11-12 covers front drive bearing adjustment. Parts 11-11 and 11-14 cover rear wheel bearing adjustments.

ALUMINUM WHEELS AND RIMS CLEANING

Whenever tire is removed, thoroughly examine the complete wheel. Remove all grease and road dirt and use a wire brush or steel wool to remove the rubber from the bead seat.

GUTTER AREA

Projections on the side wall of the gutter may cause uneven seating of the side or lock ring and lead to chipping of the gutter. Such projections should be removed.

MOUNTING AREA

Smooth all projections in the mounting area to assure even pressures when tightening nuts.

FIXED FLANGED AREA

Nicks and gouges in the vicinity of the fixed flange may lead to rim fracture.

STRAIGHTENING WHEELS

Do not heat wheels in an attempt to soften them for straightening to repair damage from striking curbs, etc. The special alloy used in these wheels is heat-treated, and uncontrolled heating from

welding affects the properties of the material. Do not weld the wheels for any reason.

VALVES

Aluminum and steel drop-center wheels for tubeless tires come from the factory with air valve installed. If it becomes necessary to replace an air valve it should be installed using 14 ft-lbs of torque on the hex nut.

MAINTENANCE AND PROTECTION IN CORROSIVE ENVIRONMENTS

Due to aluminum's natural resistance to corrosion, aluminum forged disc wheels and rims do not need to be painted for most operating conditions. Washing them (do not use highly alkaline cleaning agents) when washing the rest of the rig will be enough to keep wheels looking good for many years. Certain environments, as created by some operations, can lead to corrosion. Some of these are: livestock hauling, salt, chloride compounds used for snow removal and highly alkaline materials. When these conditions are encountered, the following practice is recommended:

1. Clean frequently with steam or high-pressure water from a hose. Use of a mild detergent will speed up the cleaning process.
2. When tires are removed, the entire wheel should be cleaned and inspected. For maximum protection, there are various types of coatings which give good results. The following procedures are suggested:

Surface Preparation

1. Remove all the soil and oil from the wheel surface with either high-pressure steam or solvent. Suitable solvents would be mineral spirits and regular paint thinner, obtained in paint stores.
2. Remove any adherent soil or oxidation products by using a wire brush.
3. Clean the surface again with solvent, using mineral spirits to remove loose products.
4. Apply a clear protective or pigmented product as follows:

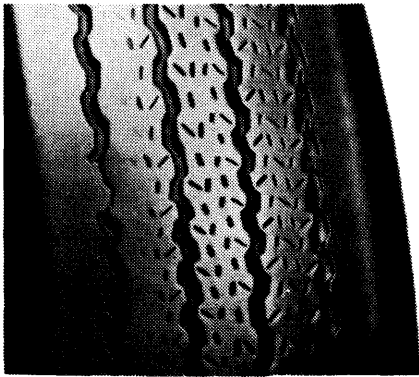

UNDERINFLATION

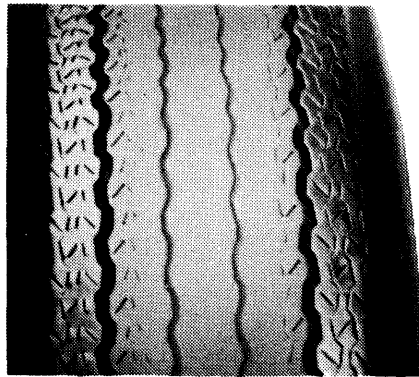

OVERINFLATION



CUPPING—UNDERINFLATION AND/OR MECHANICAL IRREGULARITIES

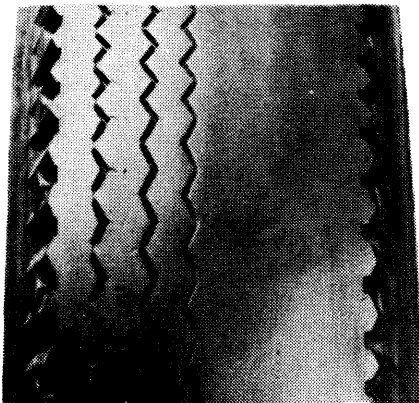

INCORRECT TOE-IN OR EXTREME CAMBER

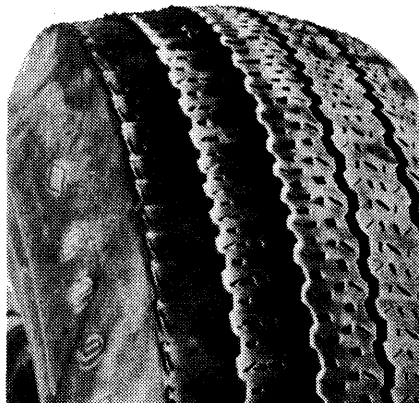

FEATHERING DUE TO MISALIGNMENT OR SEVERE CORNERING

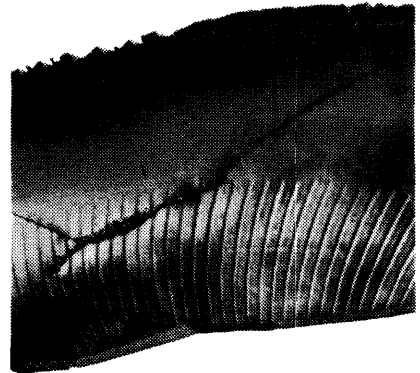

STONE BRUISE

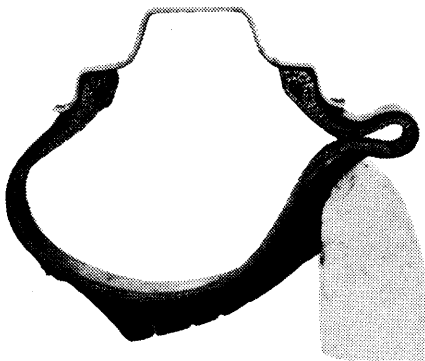

STONE BRUISE

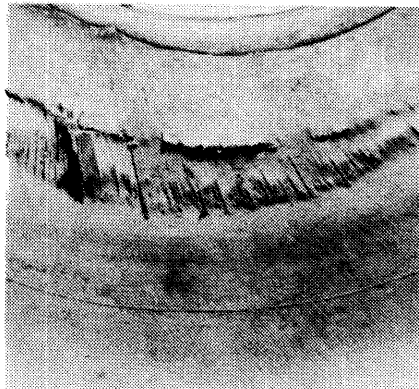

UNDERINFLATION

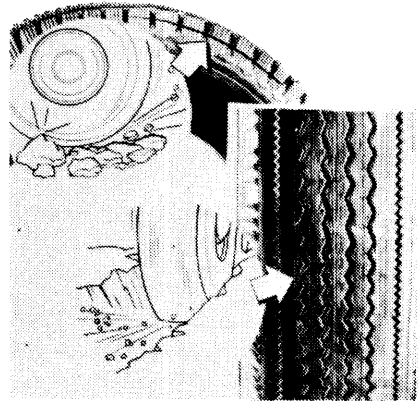

ROCK CUT

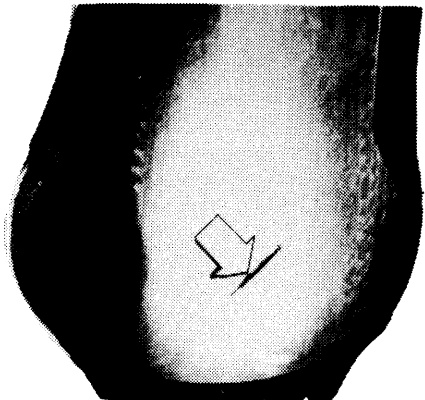

BRUISE

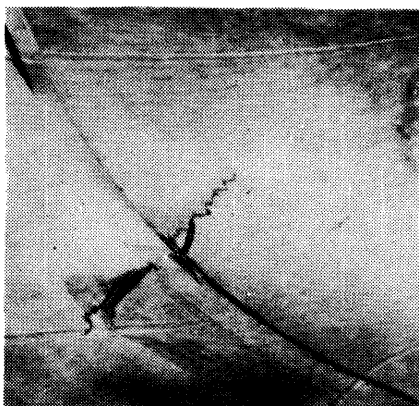

HEAT BRUISE

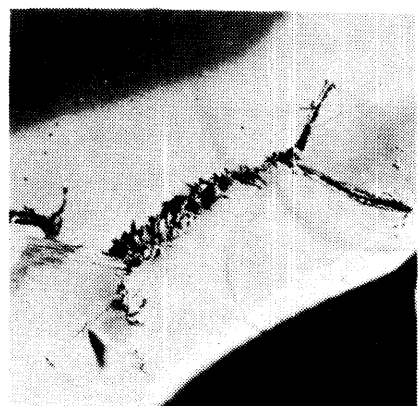

DOUBLE BRUISE—SHARP OBJECT AND RESULTING FATIGUE F1467-D

FIG. 10 Tire Wear Conditions

Clear Protective Coating

Spray apply about 1 1/2 to 2 mils wet film thickness, air curing clear epoxy polyamide meeting Military Specification MIL-C-22750 (WEP) or equivalent. To properly spray this particular coating, mix components A and B of the two-part organic coating and thin where necessary with 10 percent toluol. Spray apply with a spray gun at a pressure of 30-40 pounds (suction feed).

Pigmented Protective Coating

Primer-Spray apply the inhibited primer, meeting Military Specification MIL-C-23377 (SEP) or equivalent. Spray this primer at a 1 to 2 mil wet film thickness. Allow to air dry from 2 to 4 hours before top-coating.

Top Coat-Spray a 1 1/2 to 2 mils wet film of a leafing aluminum pigmented epoxy. Allow enough time to air dry before handling; overnight will usually be sufficient.

RIM AND WHEEL MAINTENANCE DURING TIRE INSPECTIONS

1. Check all metal surfaces thoroughly while making tire inspections, including areas between duals and on inboard side of wheel. Watch for:
 - excessive rust or corrosion build-up
 - cracks in metal
 - bent flanges, resulting from road obstructions
 - deep rim tool marks on rings or in gutter areas
 - loose, missing or damaged nuts or clamps
 - bent or stripped studs
 - damaged or missing rim drive plates
 - matched rim parts
2. Pull damaged rims or wheels.
CAUTION: Excessively corroded or cracked rims or rings can be dangerous. Deflate tires prior to the removal of rims or wheels from the vehicle.
3. Mark damaged or hazardous areas with chalk so that part will be removed from service.
4. Replace parts as required.

CAUTION: Insure that replacements are made with the proper sizes and types of rims and rings.

5. Inflate tires only to recommended air pressures.

DURING TIRE CHANGES

1. Check all metal surfaces. Watch particularly for the following items:
 - Cracks in the rim base, in the back flange and gutter areas. These are caused by deep rim tool marks, overloading and overinflating tires or using larger than recommended tire sizes.
 - Cracks in the wheel disc, between the stud holes or hand holes. These are caused by loose wheel nuts, improper installation procedures or the use of incorrect sizes or types of attaching parts.
 - Cracks through the side ring, spreading laterally through the entire section. These are caused by improper mounting and demounting techniques, impact with road obstructions, or excessive clamping torques.
 - Sprung side ring, resulting from improper mounting procedures.
 - Erosion and chipping of the bead seat of the lock ring, resulting from excessive corrosion. This may occur with this part as well as others if protective measures are not taken.
2. Replace the parts as necessary.
CAUTION: Insure that replacements are made with the proper sizes and types of rims and rings. Note: Openings between the ends of the split side rings must not be less than 3/32" except where the ring design calls for an abutting condition, or more than 5/16" after the ring is seated during operation. Split lock rings used with the endless side rings must not butt.
3. Thoroughly remove rust, dirt and other foreign materials from all surfaces. Hand or electric wire brushes, sand blasting or chemical baths may be used. Gutter of rim base should be cleared of rust and other

materials obstructing safe, positive seating of rings. Bead seat areas of rim should be free of rust and rubber deposits. This is especially important for drop-center tubeless rims, because the 15 degree bead seat is the air-sealing element.

4. Rings should be cleaned with wire brush. Pay particular attention to seating surfaces and bead seat areas. Paint rim by brush or spray with a fast-drying metal primer. Surfaces should be clean and dry prior to painting. Insure that bare metal areas on the outside or tire side of rim are covered. This is especially important on drop-center tubeless rims, because warm and sometimes moist air is in constant contact with the metal surface on the tire side of the rim.
5. Lubricate the tire side of the rim base just prior to mounting tire. Avoid the use of any lubricant which contains water or solvent that is injurious to rubber. A combination lubricant and rust-preventive compound is preferable. This protective measure is of particular importance with drop-center tubeless rims as the air in the tire is contained by the tire-side rim surface.
6. Inflate tire only to recommended air pressure.

SAFETY PRECAUTIONS

1. Insure that rings are properly seated, prior to inflation.
2. Use safety cage or lock ring guard. In emergency situations where a safety cage or portable safety device is not available, use clip-on type air chuck, so that operator may stand aside during inflation. When clip-on air chuck is used, pressure must be restricted to maximum inflation capacity of tire or rim, whichever is lower.
3. Air tank should incorporate moisture trap when used with drop-center tubeless rims in order to reduce the moisture in contact with the metal rim surfaces.

Wheels and Tires — Drop-Center Rim

PART 11-02

APPLIES TO BRONCO, E-100-E-350, F-100-F-350 AND MEDIUM TRUCKS

SUBJECT	PAGE	SUBJECT	PAGE
DESCRIPTION		REMOVAL AND INSTALLATION	
Front Wheel Assembly	02-1	Tire Replacement Precautions	02-2
Front Wheel Assembly —		Wheel Replacement	
Four Wheel Drive	02-1	E-100 to E-350, F-100 to F-350	02-1
Rear Wheel Assembly	02-1	Medium Trucks	02-2
		SPECIFICATIONS	02-2

DESCRIPTION

FRONT WHEEL ASSEMBLY

Each front wheel and tire assembly is bolted to its respective front hub and rotor assembly. Two opposed tapered roller bearings are installed in each front hub and rotor assembly (Fig. 1). A grease retainer is installed at the inner end of the hub to prevent lubricant from leaking. The entire assembly is retained on its spindle by the lock nut, adjusting nut and cotter pin.

FRONT WHEEL ASSEMBLY— FOUR-WHEEL DRIVE

The front axles used on 4-wheel drive models are described in Parts 15-30, 15-32 and 15-33 of this manual. The locking hub assemblies are described in Part 11-12.

REAR WHEEL ASSEMBLY

Information on rear wheels may be found in Group 11, Parts 11 and 14.

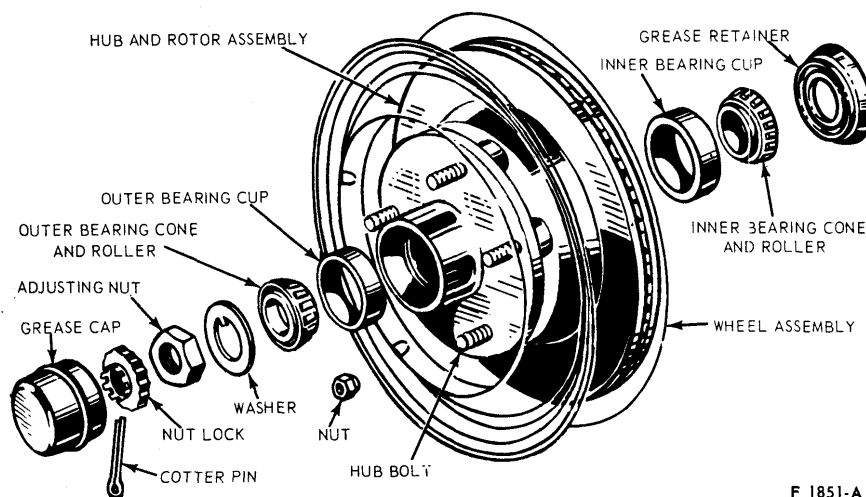

F 1851-A

FIG. 1 Front Hub, Bearings and Grease Retainer—Disc Brakes—F100-F350, 4x2, E100-E350

REMOVAL AND INSTALLATION

WHEEL REPLACEMENT

E-100 to E-350, F-100 to F-350

Removal

1. Pry off the hub cap or wheel cover (if the vehicle is so equipped), and loosen but do not remove the wheel stud nuts.
2. Raise the vehicle until the wheel and tire clear the floor.
3. Remove the wheel stud nuts and the wheel and tire from the hub and drum assembly, or the hub and rotor assembly.

Installation

1. Clean all dirt from the hub and rotor assembly. The replacement wheel and tire must be clean.
2. Position the wheel and tire on the hub and rotor assembly, and install the wheel stud nuts. Tighten the stud nuts enough to hold the wheel firmly in place. **Always tighten alternate nuts to draw the wheel evenly against the hub and drum (or hub and rotor).**

E-350 and F-350 with dual wheels have mounting bolt holes which are

alternately flared inward and outward. These surfaces must be mated when the wheels are mounted. Fig. 2 illustrates the dual wheel radial alignment locating pin used on E-350 and F-350.

3. Lower the vehicle to the floor, and tighten the wheel stud nuts to the specified torque. **On a new vehicle, and each time a wheel and tire is installed, the wheel nuts should be tightened to specification and rechecked at 500 miles.**

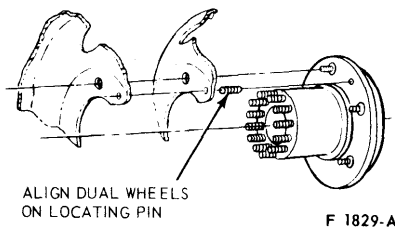

FIG. 2 Dual Rear Wheel Radial Alignment to Hub (E-350, F-350)

Medium Trucks

Removal

1. Loosen but do not remove the wheel stud nuts.
2. Raise the vehicle until the wheel and tire clear the floor.
3. Remove the wheel stud nuts and the wheel and tire from the hub and drum.

Installation

1. Clean all dirt from the hub and drum.

- The replacement wheel and tire must be clean.
2. Position the wheel and tire on the hub and drum, and install the wheel stud nuts. Tighten the stud nuts enough to hold the wheel firmly in place. **Always tighten alternate nuts to draw the wheel evenly against the hub and drum.**

- On dual wheels, be sure to back off the outer nut before tightening the inner nut. Then tighten the outer nut.
3. Lower vehicle to the floor, and tighten the wheel stud nuts to the specifications. On a new vehicle, and each time a wheel and tire is installed, the wheel nuts should be checked for tightness.

TIRE REPLACEMENT PRECAUTIONS

The tire must be completely deflated before removal, and the bead must not be damaged by a tire iron.

After installation, a tube tire should be inflated to recommended pressure,

deflated, and then inflated again to insure that the tube is not folded inside the tire. Be sure the tube flap is properly positioned before inflating the tire. On F100-350, E100-350 and B-150 it is important that each front and rear tire and wheel be balanced.

When installing tires on F-100/350, B-150, and E-100/350 vehicles, thoroughly lubricate the tire beads with lubricant ESA-M1B6A, or equivalent. Inflate the tire until both bead seats against the rim of the wheel, then deflate to the specified "Tire Inflation Pressures" shown in the 1977 Truck Owners Manual for each vehicle series. To seat the tire beads, the initial inflation for passenger-type tires is 30 psi maximum; for truck-type tubeless tires, 50 psi maximum; for truck-type tube tires 75 psi maximum. Follow the instructions supplied with the Rotunda (35-002, 35-0010 or equivalent) tire changer. Refer to Part 11-01 for diagnosis and testing procedures, safety procedures and illustrations.

SPECIFICATIONS

WHEEL TORQUE LIMITS — F-100 THRU F-350, E-100-E-350, BRONCO

Model	Nut Size	Ft-Lb
E-100-E-250 F-100, F-150 (4 x 4), Bronco, F-150, F-250 (4 x 4)	1/2-20	90
F-350, E-350 W/S R. Wheels	9/16-18 ①	135 145

Model	Nut Size	Ft-Lb
E-350, F-350, (W/Dual Rear Wheels) ① (and 7400 lb Axle) ②	9/16-18 ②	220

① E-350, F-250 and F-350 Single Rear Wheel Lug Nuts are Black in Color. (.066 inch length)

② E-350, F-350, Dual Rear Wheel Lug Nuts are Zinc Plate or Black, in Color. (.94 inch length). The Lug Nuts Should not be mixed. The Dual Wheel Lug Nuts are Left Handed Threads for Left Rear Wheels Only.

CF1804-F

Wheels and Tires — Two-Piece Rims

PART 11-03

APPLIES TO F-250, F-350 VEHICLES

SUBJECT	PAGE	SUBJECT	PAGE
DESCRIPTION	03-1	REMOVAL AND INSTALLATION (Cont'd)	
REMOVAL AND INSTALLATION	03-1	Mounting Tire to Wheel	03-1
Tire Removal and Mounting		Removal Side Ring from Rim	
Two-Piece Semi-Drop Center Rims	03-1	with Tire	03-1

DESCRIPTION

Two-piece drop center wheels with a lock ring (Fig. 1) are used with 16 inch tube-type tires only.

Refer to Part 11-01 for diagnosis and testing procedures, safety procedures and illustrations.

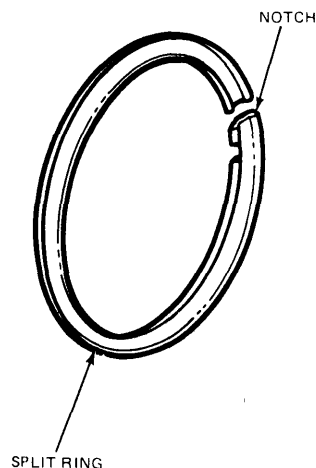
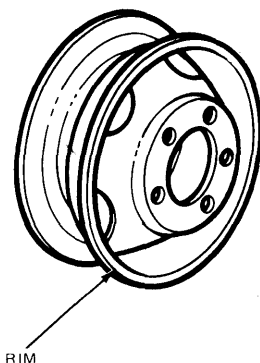
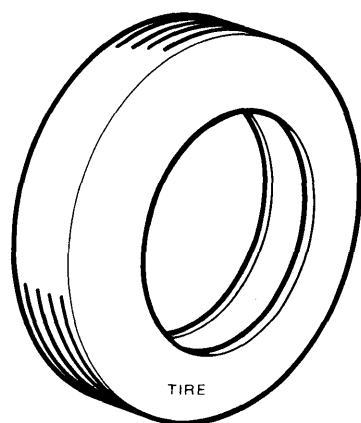

F2627-A

FIG. 1 Two-Piece Rim

REMOVAL AND INSTALLATION

The tire must be completely deflated before removal, and the bead must not be damaged by a tire iron.

After installation, a tube tire should be inflated to recommended pressure, deflated, and then inflated again to insure that the tube is not folded inside the tire. Be sure the tube flap is properly positioned before inflating the tire.

It is recommended that tire-changing equipment be used in changing all truck tires. See Safety Precautions in Part 11-01.

TIRE REMOVAL AND MOUNTING—TWO-PIECE SEMI-DROP CENTER RIM—F250-F350

Recent developments make possible the removal and mounting of tires from this type of wheel-rim combination with mechanical tire-changing equipment. If available, follow instructions of

equipment manufacturer. Otherwise, use the following instructions.

This two-piece wheel uses a split C-type ring, as shown in Fig. 2.

Removal of Side Ring from Rim with Tire

1. Remove valve core and deflate the tire completely and place the wheel (ring side up) on the floor.
2. Break the tire bead free from the rim, being careful not to damage the bead (Fig. 3).
3. Insert the straight end of the rim tool into and under the tool notch in the ring (Fig. 4).
4. Force the tool downward to disengage the ring from the rim gutter. Work the tool around the rim, freeing the ring from the rim, and remove the ring.
5. Turn the wheel over and loosen the opposite tire bead from the rim by

driving the hook end of the rim tool between the rim flange and the tire bead. Pry the tire bead away from the taper, and remove the tire from the rim (Fig. 5).

Mounting Tire to Wheel

1. Position the tube in the tire and place the wheel (gutter side up) on the floor. Lubricate both beads of the tire with ESA-M1B6A or equivalent and position the tire on the rim. It is important that the tire be lubricated well as it must be forced over the safety bead hump and the rim edge (Fig. 6). Be sure the tube flap is correctly positioned.
2. Position the ring with the tool notch about 3 inches from the valve stem.
3. Insert the rim tool under the ring at a position approximately 180 degrees from the notch and pry tire onto rim. Work the remaining section of rim over the gutter with a second tool.

4. Make certain that the ring is entirely seated in the gutter. If the ring is not seated correctly as described, it may be forced off violently, either during inflation or when the vehicle is operated.

5. After installation, inflate the tire and tube to 80 psi maximum to snap the tire beads over the bead hump and fully seat the tire against the rim and lock ring. Deflate the tire, then reinflate it to recommended pressure

to insure that the tube is not folded inside the tire. **Always use a cage or safety chain during initial inflation.**
 6. Check the end gap of the lock ring (Fig. 1), the gap should be 3/8 inch.

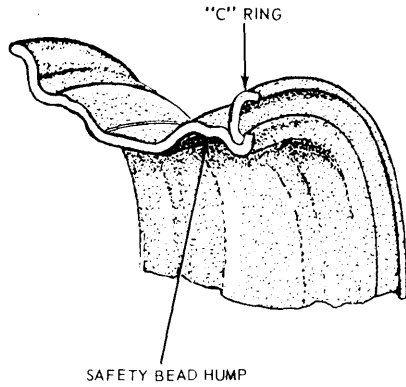

FIG. 2 Two-Piece Split Ring—Light Truck

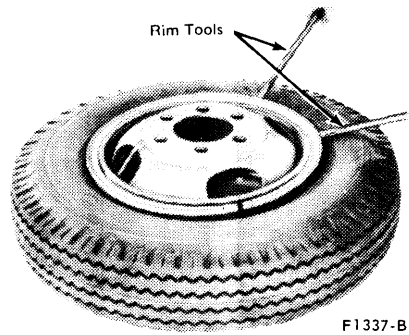
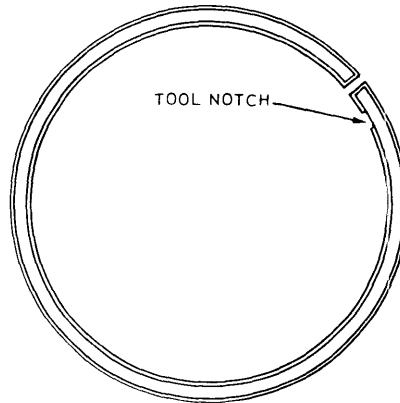

FIG. 3 Loosening Tire Bead



F1473-C

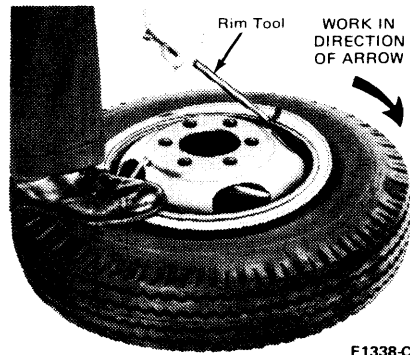
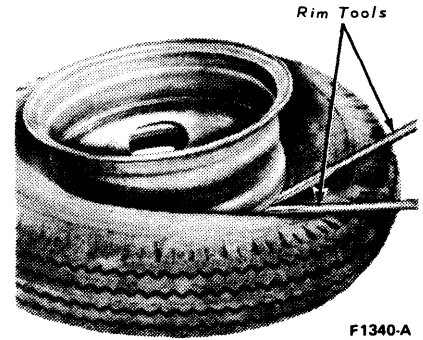
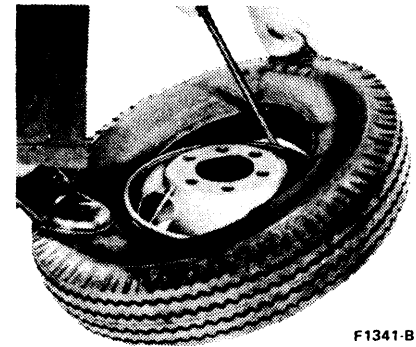

FIG. 4 Removing Split Ring



F1340-A

FIG. 5 Removing Tire From Rim



F1341-B

FIG. 6 Installing First Tire Bead on Wheel

Wheels and Tires — Three-Piece Rims

**PART
11-04**

APPLIES TO ALL 600-9000 SERIES VEHICLES

SUBJECT	PAGE	SUBJECT	PAGE
DESCRIPTION		REMOVAL AND INSTALLATION (Cont'd)	
Tires04-1	Wheel and Tire Removal from Vehicle04-2
Wheels and Rims		DISASSEMBLY AND ASSEMBLY	
Drop Center04-1	Accu-Ride XL Rims04-8
Drum Mounting04-1	Drop-Center Tubeless Rims and Wheels04-5
Three-Piece Rim04-1	Semi-Drop Wheels04-5
Two-Piece Convertible Rims04-1	Three-Piece Rims and Wheels04-7
REMOVAL AND INSTALLATION		Two-Piece Rims and Wheels04-6
Demountable Rims		SPECIFICATIONS04-11
Installation04-2		
Disc Wheel Installation04-3		

DESCRIPTION

TIRES

Both the tube type and tubeless tires are used. The tubeless tires are mounted on 15 degrees drop-center rims and wheels. The tube type tires are mounted on semi-drop wheels, two-piece flatbase rims or wheels, and three-piece flatbase rims or wheels (Figs. 1 and 2).

WHEELS AND RIMS

DROP-CENTER

The tubeless tires are all mounted on drop-center rims and wheels. The drop-center rim or wheel is of single-piece construction and is available in both demountable rim and disc wheel configuration. The drop-center rim or wheel has a 15 degree bead seat for sealing tubeless tires. The drop-center rim or wheel is available in either aluminum or steel.

TWO-PIECE CONVERTIBLE RIMS

The two-piece convertible rim consists of a side ring and flatbase rim and is available in the demountable rim or disc wheel configuration. The rim has a 5 degree bead seat for tube type tires.

THREE-PIECE RIM

The three-piece rim consists of a lock ring, side ring and flatbase type rim. It

is available in the demountable rim or disc wheel configuration. The disc wheel is available in aluminum or steel, however, the lock ring and side ring are made of steel in all cases. The rim has a 5 degree bead seat for tube type mountings.

DRUM MOUNTING

Both the inboard and outboard drum mountings are used. On inboard mounting the drum is inside the mounting hub or spoke wheel, on outboard mounting the drum is outside the mounting hub.

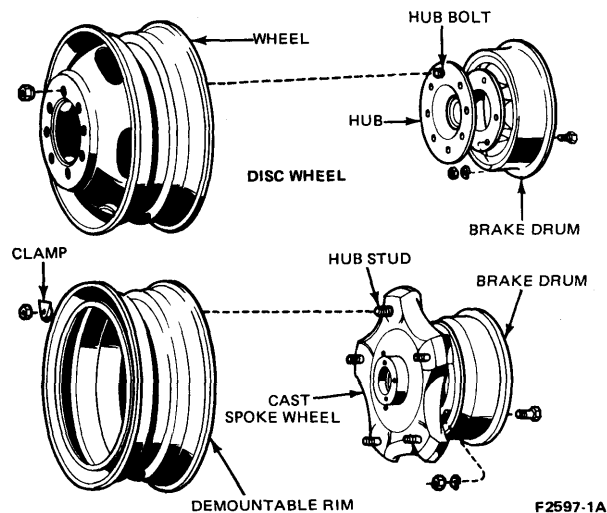

FIG. 1 Typical Front Wheel/Rim Installation

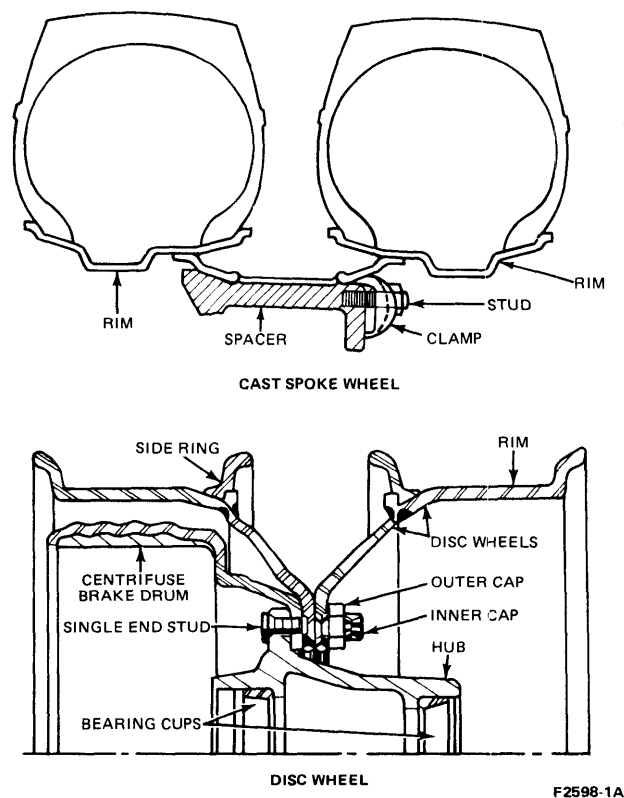

FIG. 2 Typical Rear Wheel/Rim Installation

REMOVAL AND INSTALLATION

WHEEL AND TIRE REMOVAL FROM VEHICLE

1. Prior to removal of the tire and rim from the vehicle, deflate the tire completely by first reducing the pressure as much as possible by depressing the valve core plunger, then removing the valve core. (See safety precautions in this Part). If working on dual wheels, deflate both tires completely before loosening the mounting bolts.
2. Loosen, but do not remove the wheel stud nuts.
3. Raise the vehicle until the wheel and tire clear the floor.
4. Remove the wheel stud nuts and the wheel and tire from the hub and drum. On dual disc wheels, the inner cap nut will also have to be removed if the inner tire is to be removed. On dual cast spoke wheels, the spacer will also have to be removed.

DEMOUNTABLE RIMS INSTALLATION

1. Make sure that all parts, including rims, rings, spacer bands, and cast wheel studs are free from damage, dirt or rust as described in this Part. Replace any damaged parts.

2. With dual wheels, place rims and spacer band on wheel and proceed to the next step. On single wheels, place the rim on the wheel and proceed to Step 7.

Note: Spacer bands are designed to render adequate lateral strength with the minimum amount of weight. Spacer bands should not be subjected to loads or pressures other than those loads or pressures present during normal use.

3. Check the spacer band for concentricity, and ensure that it has not been distorted or bent, or otherwise mishandled in shipment.
4. Do not move the vehicles, wheels, axles or assemblies by rolling on spacers.
5. Place the inside rim over the cast spoke wheel as far as possible up to the mounting bevel.
6. Push the spacer band over the cast spoke wheel with a consistent pressure on both sides. Guard against cocking. The band should fit snugly to the spokes and against the inside rim gutter edge. (At this point, the concentricity can be checked by turning the spacer band on the wheel).

7. Install outer rim (or rim in case of single wheel) with the rim in between the spokes as shown in Fig. 3. Install the clamps and start the nuts onto the studs.
8. Refer to Fig. 4 for the cast spoke wheel triangulation torquing and proceed to the next step.
9. Turn nut No. 1 until snug.
10. Rotate the wheel/rim assembly until nut No. 3 is in the top position. Turn until snug.
11. Again rotate the wheel/rim assembly until nut No. 4 is in the top position and turn the nut until snug. Since the entire weight of the tire/rim assembly is on the top spoke position, this procedure allows even application of force against three points of the rim for proper alignment.
12. Repeat the triangle procedure; this time bringing each nut to recommended torque of 220-260 ft-lbs.
13. Bring remaining nuts to torque of 220-260 ft-lbs.
14. Check to see that clamps do not bottom out, and be sure that on dual wheels, rim edges consistently meet the spacer band edges.
CAUTION: Insufficient mounting torque can cause rim slippage,

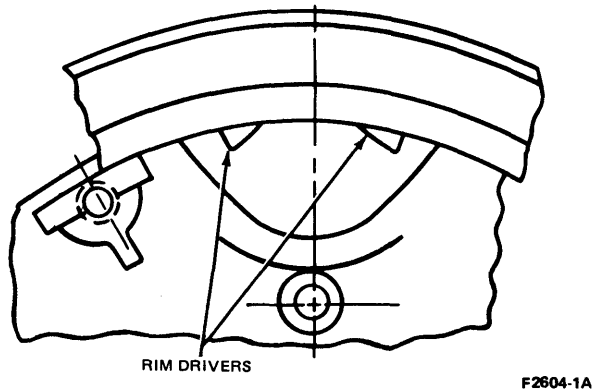

FIG. 3 Cast Spoke Wheel Rim Driver Arrangement

resulting in broken valves, worn parts and damaged tires. Excessive mounting torque can cause damage by stripping studs, collapsing spacer bands or forcing rims into an out-of-round condition. Note: Even when the triangulation method is used, nuts will still lose torque when the vehicle is operated. This is caused by the "seating in" of the rim assembly to the wheel. After 50-100 miles of operation the nuts should again be brought to recommended torque and

thereafter periodically inspected and retorqued. The wheel/rim assembly will then remain tight, barring accidents such as stud breakage or clamp failure.

DISC WHEEL INSTALLATION

1. Check all parts for damage, including wheels and rings. Insure that studs, nuts, and mounting faces of hub and wheels are clean and free from grease as described in this Part. Replace any worn or damaged parts.
2. Mount single wheel or inner dual wheel over studs, being careful not to damage stud threads (Fig. 5). Studs and cap nut threads should be dry. No oil or lubricant should be used.
3. Draw the single cap nut or dual inner cap nut alternately in the sequence shown in Fig. 6. Left side wheels have left-hand threads. Do not tighten them fully, however. This procedure will permit uniform seating of the nuts and insure even, face-to-face contact of the wheels and hub.
4. Tighten the nuts fully to 400-500 ft-lbs in the same sequence. Mount the outer wheel (for dual wheels) and repeat the tightening procedure.

CAUTION: Insufficient mounting torque can cause wheel shimmy, resulting in damage to parts and extreme tire tread wear. Excessive mounting torque can cause studs to break and discs to crack in the stud hole area.

5. After 50 to 100 miles of service recheck the wheel nut torque. When the inner cap nut (on dual wheels) are re-tightened, be sure to first loosen the outer cap nuts several turns; then re-tighten.

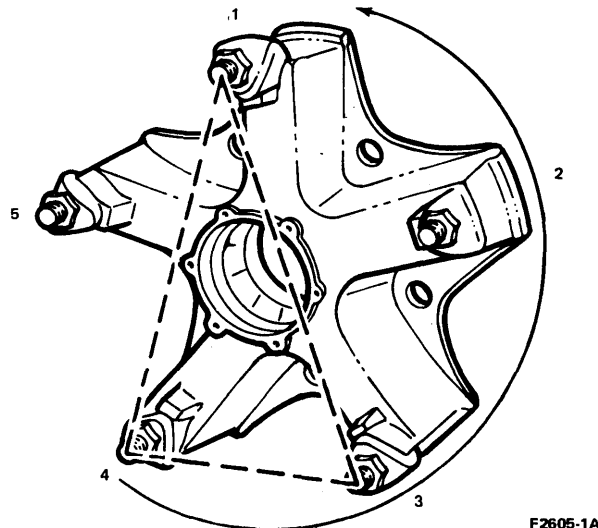
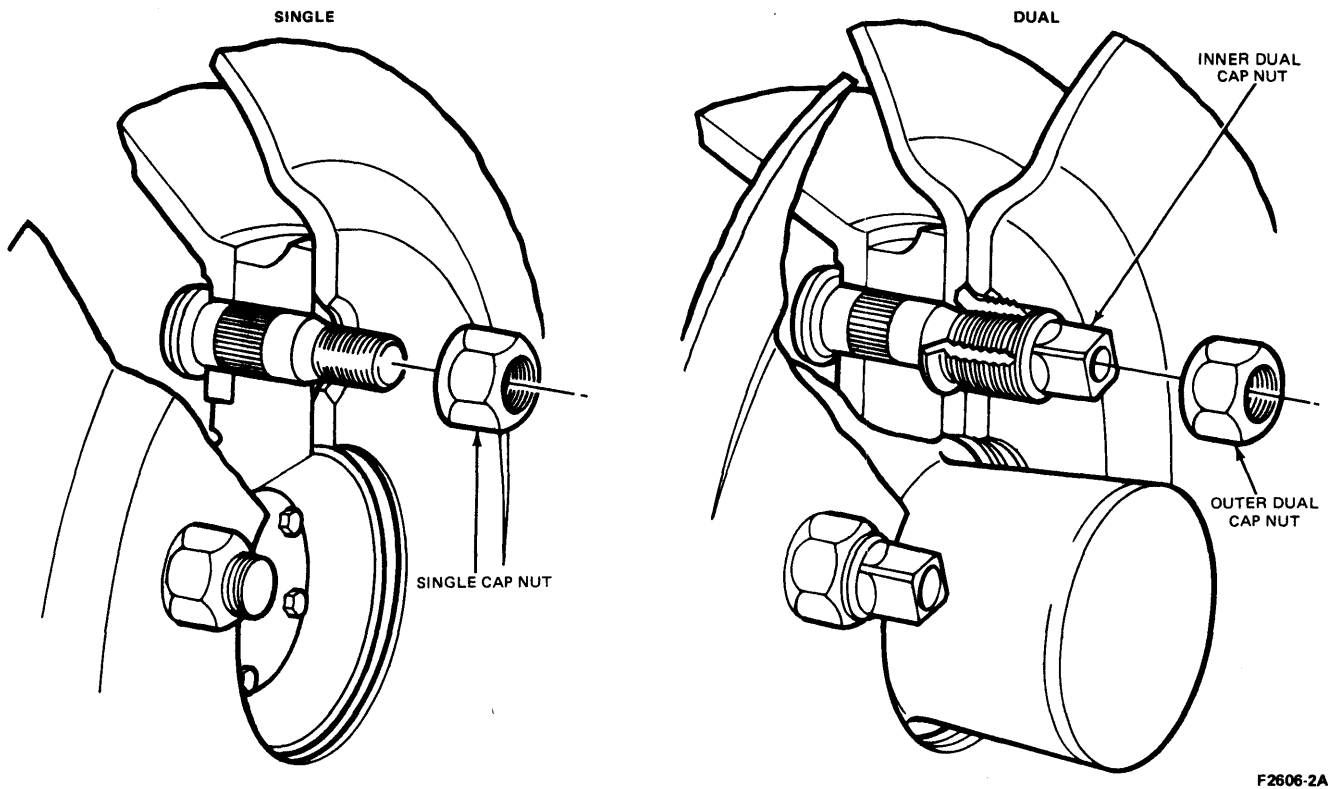
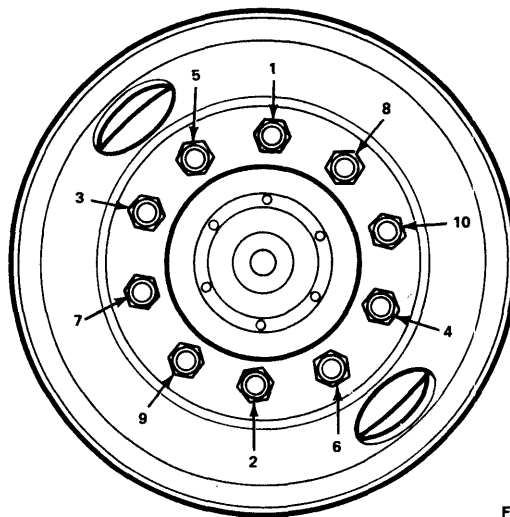

FIG. 4 Cast Spoke Wheel Triangulation Torquing



F2606-2A

FIG. 5 Disc Wheel Mounting



F2607-1A

FIG. 6 Disc Wheel Tightening

DISASSEMBLY AND ASSEMBLY

DROP-CENTER TUBELESS RIMS AND WHEELS

DEMOUNTING

1. Make certain the tire is completely deflated with the valve core removed.
2. With the tire lying flat, loosen both beads by walking on the tire with the heels close to the rim.
3. With the wide side of the rim down, lubricate the top bead.
4. With the stops toward the rim, insert the spoon ends of the two tubeless tire tools about 10" apart (Fig. 7, View A). Holding the bead in the well with foot, pull one tool toward the center of the rim.
5. Hold the tool in position with one foot and pull the second tool toward the center of the rim (Fig. 7, View B). Progressively work the bead off the rim, taking additional bites with the tools as necessary.
6. Stand the assembly in a vertical position. Lubricate the second bead.
7. At the top of the assembly insert the straight end of the tool between the bead and back the flange of the rim at about a 45 degree angle (Fig. 7, View C). Turn the tool so that it is perpendicular to the rim. Pry the second bead off.
8. Clean and inspect the wheel and tire as previously described in this Part.

MOUNTING

1. Be sure the right valve is used and properly installed in the rim.
2. Inspect the rim to insure the bead seats are clean and smooth.
3. Place the rim on the floor with the wide side down and lubricate the first bead of the tire and upper bead seat of the rim (Fig. 8, View A).

4. Push the first bead into the well of the rim and onto the rim as far as possible. Using the straight end of the tool (with stop resting on the rim flange) take small bites to work remaining section of the first bead onto rim (Fig. 8, View B).
5. Hold the second bead in the well by standing on the tire and anchor with the vise-grip pliers (snub side toward the tire).
6. Using the spoon end of the tire tool with stop toward the rim, use small bites until the bead slips over the flange. If necessary, insert the second tire tool and lubricate last 6" of bead before completing the mounting (Fig. 8, View C).
7. Inflate the tire as previously described in this Part, making certain that all the safety precautions are followed. Check for leaks.

SEMI-DROP WHEELS

CAUTION: Demounting and mounting truck tires can be extremely dangerous if proper safety precautions are not followed. Before starting with this procedure, PLEASE read all safety precautions described in Part 11-01.

DEMOUNTING

1. Place the tire and wheel on the floor with the side ring up. Make certain that the tire is completely deflated and that the valve core is removed.
2. To loosen the first bead, drive the hooked end of the rim tool between the tire and rim flange and press downward on the bead (Fig. 9, View A).
3. Progress around the rim, using the two tools as shown in View A.

4. To remove the ring, insert the tool in the notch and force the ring opposite of the notch into the gutter, then pry off (Fig. 9, View B).
5. Pry out and up on the side ring, carefully but firmly. Take care not to bend the side ring.
6. Force the upper tire bead into the well opposite the valve slot and with the tire tool, pry the opposite portion of the bead over the edge of the rim (Fig. 9, View C).
7. Turn the tire over, and by means of rim tools, loosen the bead on the opposite bead seat. Insert the straight end of the tool between the bead and back flange of the rim at about a 45 degree angle. Turn tool so that it is perpendicular to the rim. Make sure one portion of the second bead is still in the rim well, then pry the opposite portion of the bead over the edge of the rim. This will free the tire (Fig. 9, View D).
8. Clean and inspect the wheel and tire as previously described in this Part.

MOUNTING

1. Place the tire on the rim so that the valve is in line with the rim slot and insert the valve through the slot. Force the first bead down into the well of the rim just to side of the valve with foot. Mount the first bead over the rim lip with the rim tool progressing from each side of the foot approximately opposite foot (Fig. 10, View A).
2. To apply the second bead, start at the point opposite the valve and press the tire bead over the rim lip and into the rim well with foot pressure. Mount the remainder of the bead over the rim lip by means of thin tire tool,

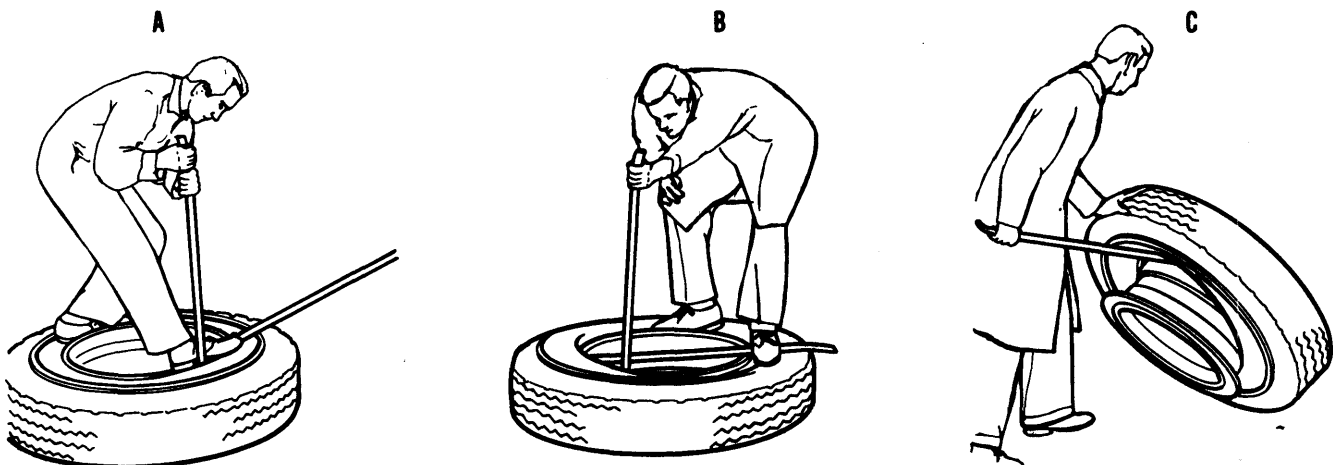

FIG. 7 Tubeless Tire Removal

being careful not to pinch the tube. If necessary, insert the second tire tool and lubricate the last 6" of the bead before completing the mounting (Fig. 10, View B).

- Place the half of side ring opposite tool notch under the rim lip with cutaway portions in the position as shown. Force part of the ring directly opposite of the notch down below the rim lip approximately 1" to aid in mounting. Insert the thin end of the rim tool in the tool notch and pull ring outward over the rim lip, while striking the ring with a rubber mallet to start engagement over the rim. Remove the rim tool, then strike the remaining portion of the side ring to force it down over the rim lip (Fig. 10, View C).
- Inflate the tire as previously described in this Part, making certain that all

safety precautions are followed. Check for leaks.

TWO-PIECE RIMS AND WHEELS

CAUTION: Demounting and mounting truck tires can be extremely dangerous if proper safety precautions are not followed. Before starting with this procedure, PLEASE read all safety precautions described in Part 11-01.

DEMOUNTING

- Place the tire on the floor and make certain that the tire is completely deflated and that the valve core is removed.
- Insert the hooked end of the tire tools between the side-ring and the side wall of the tire and pry the bead loose from the side-ring by downward pressure on the rim tools. Continue prying progressively around the tire

until the bead is completely free from the side ring (Fig. 11, View A).

- Insert the tapered end of the tool into the prying notch on the side ring and pry the side ring from the groove in the rim by prying progressively around the tire until the ring is free (Fig. 11, View B).
- Turn the assembly over and unseat the second tire bead from the rim. Lift the rim from the tire (Fig. 11, View C).
- Clean and inspect the wheel and tire as previously described in this Part.

MOUNTING

- Insert the tube and flap into the tire and inflate sufficiently to round out the tube. Apply rubber lubricant to the inside and outside surfaces of both the tire beads and to that portion of the tube and flap that appears between the beads.

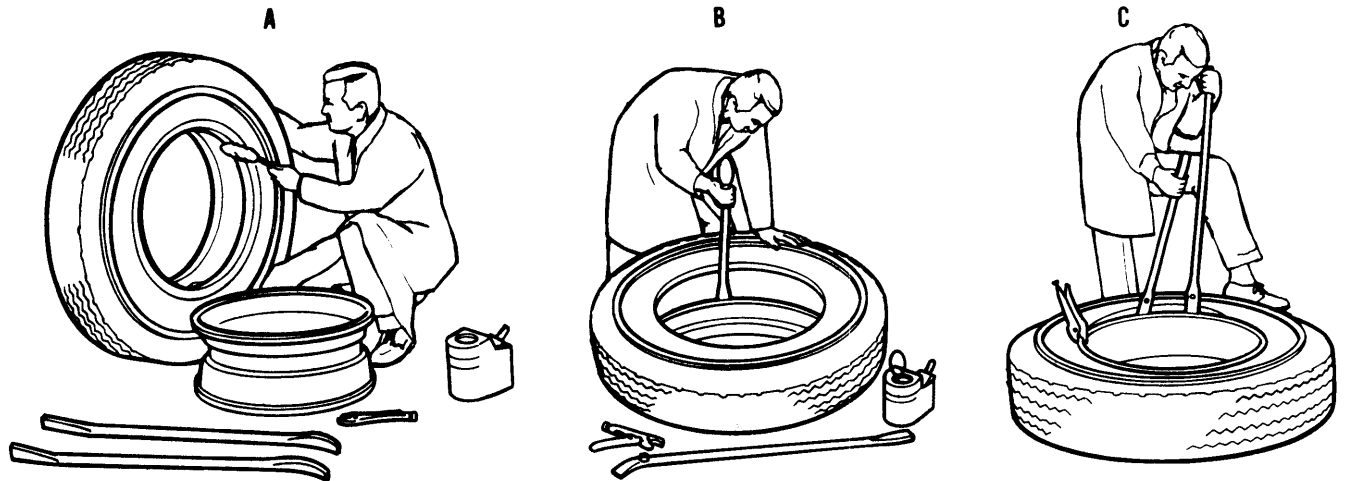

F2609-2A

FIG. 8 Tubeless Tire Mounting

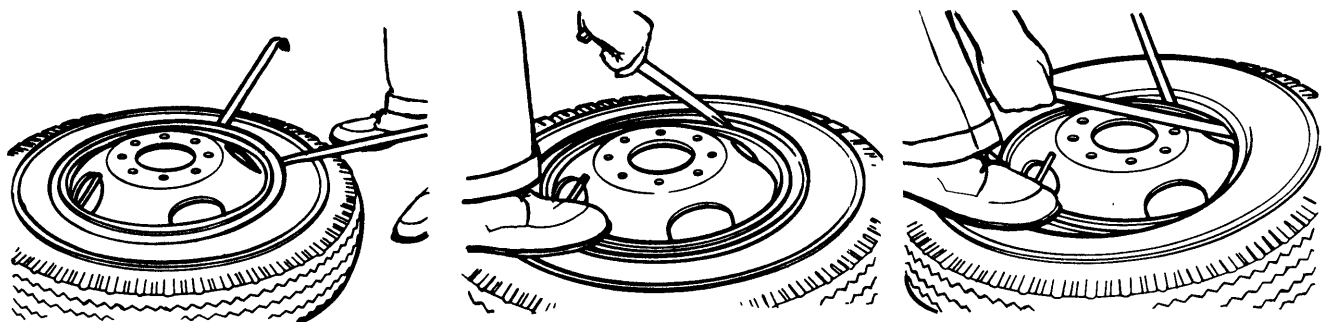

DEMOUNTING: First remove valve core to completely deflate tire before loosening mounting bolts. Place tire and wheel on floor with side ring up. To loosen first bead, drive hooked end of rim tool between tire and rim flange and press downward on bead. Progress around rim, using 2 tools, as shown.

To remove ring, insert tool in notch and force ring opposite of notch into gutter, then pry off. Pry out and up on side ring, carefully but firmly. (Be careful not to bend side ring.)

Force upper tire bead into well opposite the valve slot and with tire tool pry opposite portion of bead over edge of rim.

F2610-2A

FIG. 9 Demounting Semi-Drop Wheels

- Lay the rim flat on the floor with the valve slot up. Align the valve with the valve slot, place the tire onto the rim and insert the valve through the valve slot (Fig. 12, View A).
- Place the side-ring on the rim base so that the ring split is opposite the valve stem. Place the leading end of the ring into the groove (Fig. 12, View B).
- Starting at the valve side, progressively "walk" the side ring into place. Check to see that the ring is fully seated in the groove.
Note: Openings between the ends of the split side ring must not be less than 5/32-inch except where the ring design calls for an abutting condition, or more than 5/16-inch after ring is seated in during operation.
- Inflate the tire as previously described in this Part, making certain that all

safety precautions are followed. Check for leaks.

THREE-PIECE RIMS AND WHEELS

CAUTION: Demounting and mounting truck tires can be extremely dangerous if proper safety precautions are not followed. Before starting with this procedure, PLEASE read all safety precautions described in Part 11-01.

DEMOUNTING

- Place the tire and wheel on the floor with the side ring up and make certain that the tire is completely deflated with the valve core removed.
- Insert hooked end of the tire tools between the side ring and side-wall of the tire (Fig. 13, View A). Pry the bead loose from the side ring by downward pressure on the rim tools.

Continue prying progressively around the tire until the bead is completely free from the side ring.

- With the side flange and tire bead pushed down, insert the tapered end of the tool into the notch near the split in the lock ring and push downward to pry the lock ring from the gutter groove of the rim base (Fig. 13, View B).
- Use the hooked end of the tool to complete removal of the lock ring, progressively working around the tire (Fig. 13, View C). Lift off the side flange.
- Turn the assembly over and unseat the second tire bead from the rim. Lift the rim from the tire. Remove the tube and flap (if used) from the tire.

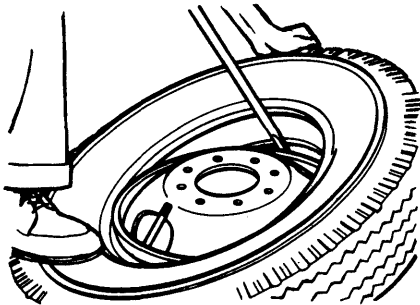

MOUNTING: Place tire on rim so that valve is in line with valve hole and insert valve through valve hole. Force first bead down into well of rim just to side of valve with foot. Mount first bead over rim gutter with rim tool progressing from each side of foot to point approximately opposite foot.

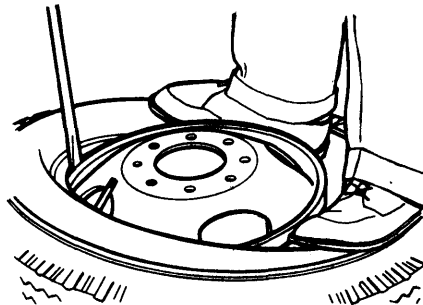

To apply second bead, start at point opposite valve and press bead toe over rim gutter and into rim well with foot pressure. Mount remainder of bead over rim gutter by means of thin tire tool, being careful not to pinch tube.

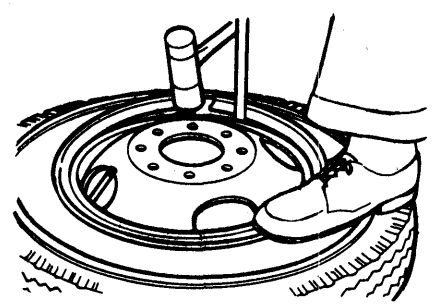

Place half of side ring in rim gutter with cutaway portions in position as shown. Insert thin end of rim tool or heavy screwdriver and pull ring outward toward centered position. Strike with mallet forcing ring into gutter. Inflate tire in safety cage.

F2611-2A

FIG. 10 Mounting Semi-Drop Wheels

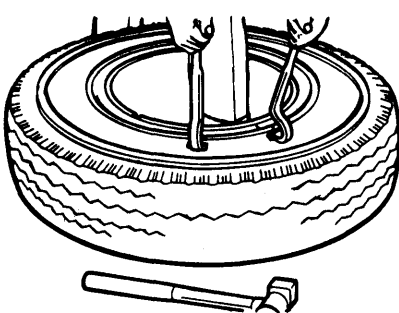

DEMOUNTING: Before removing tire and rim assembly from truck, deflate tire completely by removing valve core. If working on duals, deflate both tires completely before loosening mounting bolts. Remove tire from truck and place on floor side, ring up. Insert hooked end of tire tools between side-ring and side-wall of tire and pry bead loose from side-ring by downward pressure on rim tools. Continue prying progressively around tire until bead is completely free from side-ring.

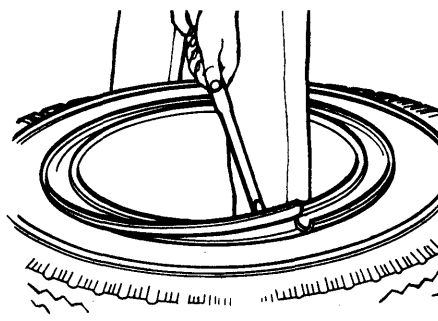

Insert tapered end of tool into prying notch on side-ring and pry side-ring from its groove in rim by progressively around tire until ring is free.

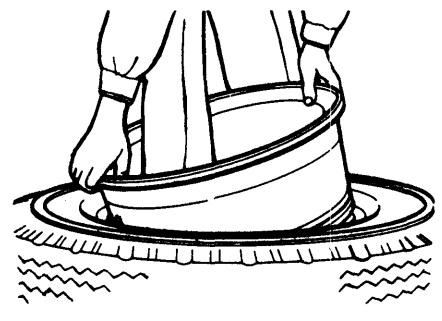

Turn the assembly over and unseat second tire bead from rim. Lift rim from tire. Remove tube and flap, if any, from tire.

F2612-2A

FIG. 11 Demounting Two-Piece Rims and Wheels

MOUNTING

1. Insert the tube and flap (if used) into the tire and inflate sufficiently to round out the tube. Apply rubber lubricant to the inside and outside surfaces of both the tire beads and to that portion of the tube and flap that appears between the beads.
2. Lay the rim flat on the floor with the valve slot up. Align the valve with the rim valve slot. Place the tire into the rim and insert the valve through the valve slot (Fig. 14, View A).

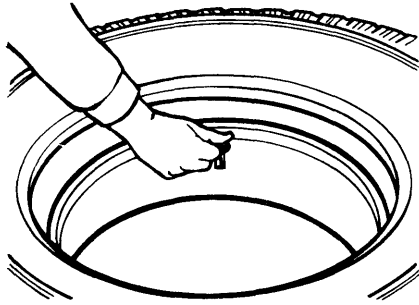

MOUNTING: Insert tube and flap into tire and partially inflate to round out tube. Apply rubber lubricant to inside and outside surfaces of both beads and to that portion of tube and flap that appears between beads. Lay rim flat on floor with valve slot up. Align valve with rim valve slot, place tire onto rim and insert valve through valve slot.

3. Place side flange on the rim base and stand on flange to position the flange below the gutter grooves in the rim base (Fig. 14, View B).
4. Snap the leading end of the lock ring into the gutter groove of the rim base and progressively "walk" the lock ring into place (Fig. 14, View C). Check to ensure that the lock ring is fully seated in the gutter groove.
5. Inflate the tire as previously described in this Part, making certain that all

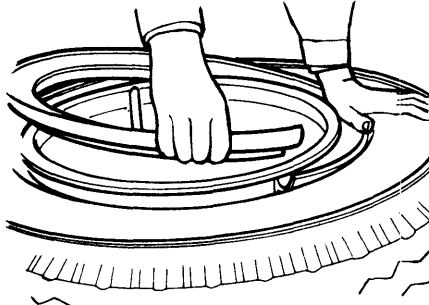

Place side-ring on the rim base so that ring split is opposite valve stem. Place leading end of ring into the groove in the rim as shown.

safety precautions are followed. Check for leaks.

ACCU-RIDE XL RIMS

CAUTION: Demounting and mounting truck tires can be extremely dangerous if proper safety precautions are not followed. Before starting with this procedure, PLEASE read all safety precautions described in Part 11-01.

For mounting and demounting instructions for Accu-Ride XL rims refer to Fig. 15.

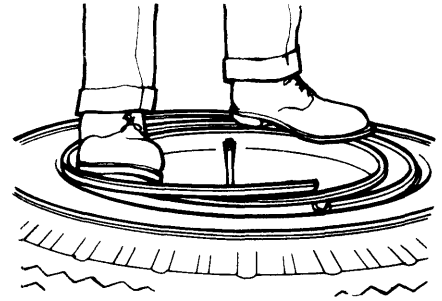

Starting at the valve side, progressively "walk" side-ring into place. Check to insure ring is fully seated in groove.

F2613-2A

FIG. 12 Mounting Two-Piece Rims and Wheels

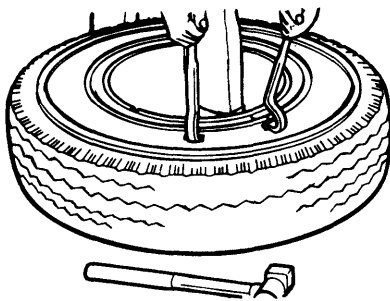

DEMOUNTING: Before removing tire and rim assembly from truck, deflate tire completely by removing valve core. If working on duals, deflate both tires completely before loosening mounting bolts. Remove tire from truck and place on floor side, ring up. Insert hooked end of tire tools between side-ring and side-wall of tire and pry bead loose from side-ring by downward pressure on rim tools. Continue prying progressively around tire until bead is completely free from side-ring.

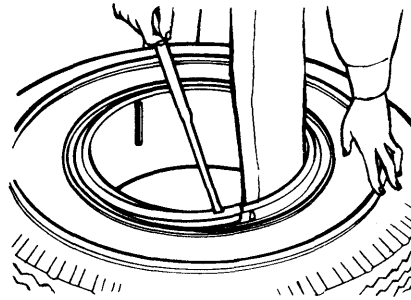

With side flange and tire bead pushed down, insert tapered end of tool into notch near split in lock-ring and push downward to pry lock-ring from gutter groove of rim base.

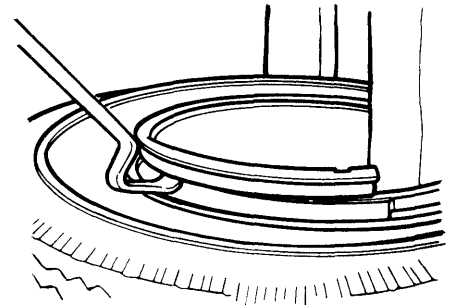

Use hooked end of tool to complete removal of lock-ring, progressively working around tire. Lift off side-flange. Turn the assembly over and unseat second tire bead from rim. Lift rim from tire. Remove tube, and flap if any, from tire.

F2614-2A

FIG. 13 Demounting Three-Piece Rims and Wheels

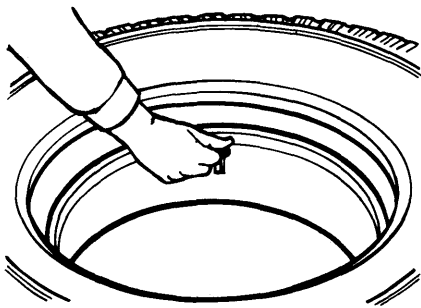

MOUNTING: Insert tube and flap into the tire and partially inflate to round out tube. Apply rubber lubricant to inside and outside surfaces of both beads and to that portion of tube and flap that appears between beads. Lay rim flat on floor with valve slot up. Align valve with rim valve slot, place tire onto rim and insert valve through valve slot.

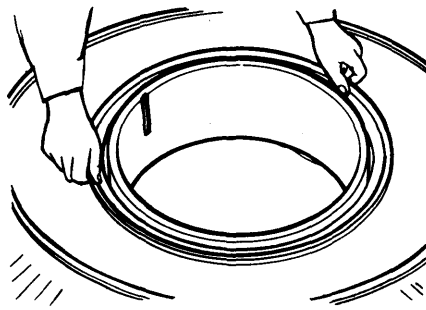

Place side flange on rim base and stand on flange to position it below gutter grooves in rim base.

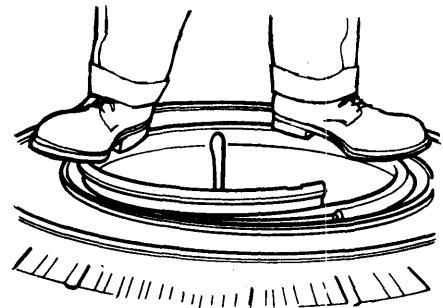

Snap leading end of lock-ring into gutter groove of rim base and progressively "walk" lock into place. Check to insure lock-ring is fully seated in gutter groove.

F2615-2A

FIG. 14 Mounting Three-Piece Rims and Wheels

Tools required: 1 rim mallet — 2 tubeless tire tools RT-31 — 2 rim tools RT-29 or RT-30

MOUNTING

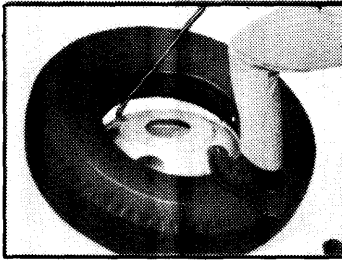

Place tire on rim so that valve is in line with rim slot and insert valve through the slot. Force first bead down into well of rim with foot just to side of valve. Mount first bead over rim lip with rim tool working alternately from each side of foot until first bead is seated.

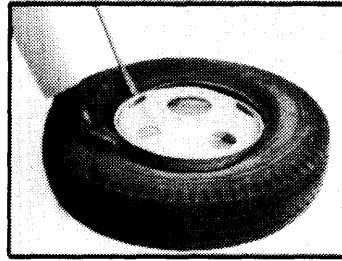

To apply second bead, start at point opposite valve and press tire bead over rim lip and into rim well with foot pressure. Mount remainder of bead over rim lip by means of thin tire tool, being careful not to pinch tube. If necessary, insert second tire tool and lubricate last 6" of bead before completing mounting.

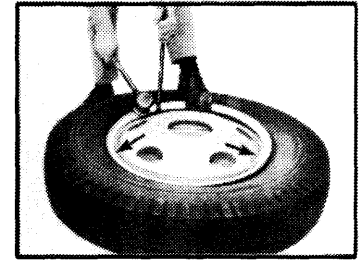

Place the half of side ring opposite tool notch under rim lip with cutaway portions in position as shown. Force part of ring directly opposite notch down below rim lip approx. 1" to aid in mounting. Insert thin end of rim tool in tool notch and pull ring outward over rim lip, while striking ring with rubber mallet to start engagement over rim. Remove rim tool, then strike remaining portion of side ring to force it down over rim lip.

DEMOUNTING

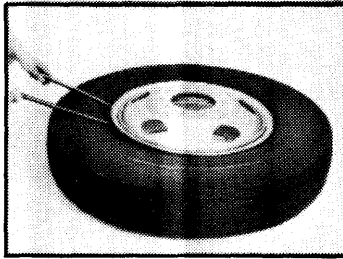

First, standing clear of rim, remove valve core to completely deflate tire. Place tire and wheel on floor with side ring up. To loosen first bead, drive hooked end of rim tool between tire and rim flange and press downward on bead. Progress around rim, using 2 tools, as shown.

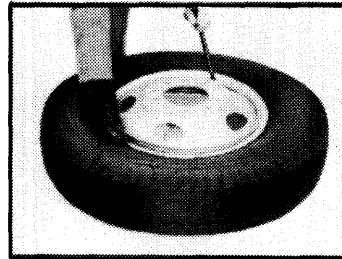

To start removal of ring, insert rim tool into tool notch and pry up on ring while forcing opposite side of ring down at least 1" as shown. To fully remove ring, insert a second rim tool to the right of tool notch and work ring off with this second tool.

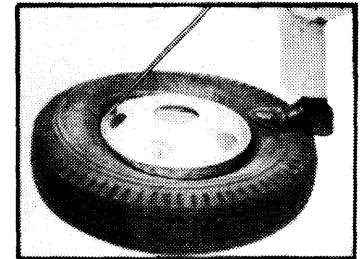

Force upper tire bead into well opposite the valve slot and with tire tool pry opposite portion of bead over edge of rim.

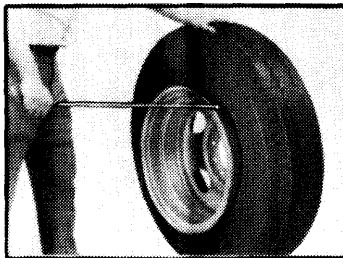

Turn tire over, and by means of rim tools, loosen bead on opposite bead seat.

Stand assembly in vertical position. Lubricate second bead. At top of assembly insert straight end of tool between bead and back flange of rim at about a 45° angle. Turn tool so that it is perpendicular to rim.

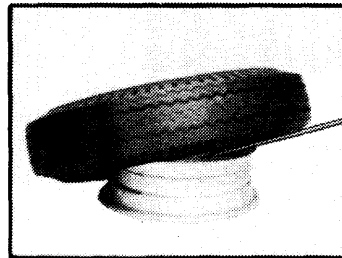

Make sure one portion of second bead is still in the rim well, then pry opposite portion of bead over edge of rim. This will free the tire from the rim as shown.

SPECIAL NOTE:

Interchanging of 20 x 6.0 XL and 20 x 6.5 XL side ring is not recommended. The 20 x 6.0 XL side ring will not carry the load of the 20 x 6.5 XL assembly, even though parts will satisfactorily fit together.

The 20 x 6.5 XL side ring satisfactorily fits the 20 x 6.0 XL assembly but flange height is greater than that of rim.

Effective 9/13/74 SR238XL-3 revised as common ring for both 20 x 6.0 and 20 x 6.5 sizes.

FIG. 15 Accu-Ride XL Rims—Mounting and Demounting

SPECIFICATIONS**TIRE SIZES AND TYPES**

Type	Size	Code Letter
Tube Type	10.00 x 20 (12 PR)	F
	10.00 x 20 (14 PR)	G
	11.00 x 20 (12 PR)	F
	11.00 x 20 (14 PR)	G
	10.00 x 22 (12 PR)	F
	10.00 x 22 (14 PR)	G
	11.00 x 22 (12 PR)	F
	11.00 x 22 (14 PR)	G
Tubeless	11.00 x 22.5 (12 PR)	F
	11.00 x 22.5 (14 PR)	G
	12.00 x 22.5 (12 PR)	F
	12.00 x 22.5 (14 PR)	G
	11.00 x 24.5 (12 PR)	F
	11.00 x 24.5 (14 PR)	G
	12.00 x 24.5 (12 PR)	F
	12.00 x 24.5 (14 PR)	G
Tubeless Radials	10R x 22.5 (14 PR)	G
	11R x 22.5 (14 PR)	G
	11R x 24.5 (14 PR)	G

CF2616-1A

WHEEL TORQUE LIMITS

Description	Nut Size	Torque Limits (ft-lb)
Disc Wheel Nuts	3/4-16	450-500
	1-1/8-16	450-500
Cast Wheel Rim Clamp Nut	3/4-10	200-260

CF2617-2A

Wheels, Hubs and Bearings — Front (Except Front Drive)

PART 11-10

APPLIES TO ALL MODELS

<u>SUBJECT</u>	<u>PAGE</u>	<u>SUBJECT</u>	<u>PAGE</u>
DESCRIPTION		REMOVAL AND INSTALLATION	
Front Wheel Assembly	10-1	Disc Brakes	
ADJUSTMENTS		Medium, Heavy and Extra	
Front Wheel Bearing		Heavy Vehicles	10-5
All Medium, Heavy and Extra		F-100 — F-350, E-100 — E350	10-5
Heavy Trucks	10-4	Drum Brakes	
Double Nut with Lock Ring		P-600	10-4
9000 and 12000 Pound		Front Wheel Grease Seal	
Front Axle	10-4	and Bearings	10-4
Single Nut with Cotter Pin		Front Hub Seal	
16000, 18000 and 20000		National	10-6
Pound Front Axle	10-4	Stemco	10-6
F-100 — F-350 (4x2) and		Oil Lubrication	
E-100 — E-350	10-4	Medium, Heavy, Extra Heavy	
P-600	10-4	Vehicles	10-6
		SPECIFICATIONS	10-9

DESCRIPTION

FRONT WHEEL ASSEMBLY

Each front wheel and tire assembly is bolted to its respective front hub and brake drum or hub and rotor assembly. Two opposed tapered roller bearings are installed in each hub, Figs. 1 and 2. A

grease retainer is installed at the inner end of the hub to prevent lubricant from leaking into the drum or onto the rotor. The entire assembly is retained to its spindle by the lock nut or adjusting nut

and cotter pin, or an adjusting nut and lock nut combination.

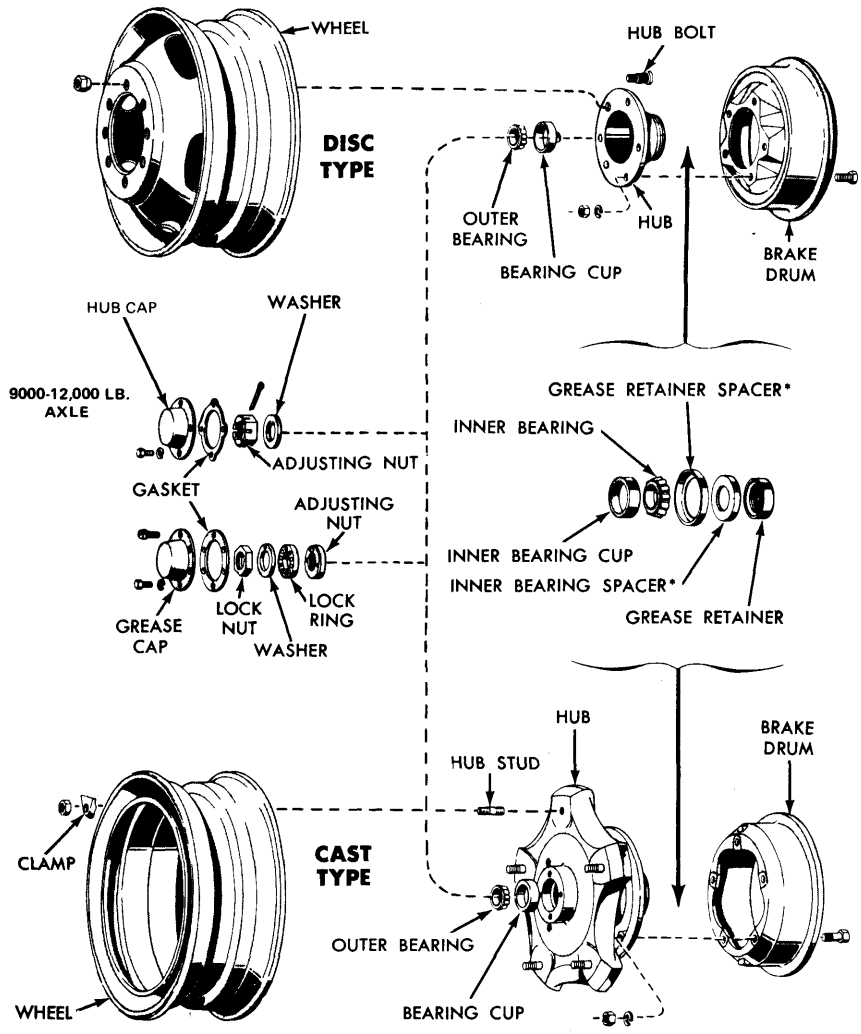

F1466-C

FIG. 1 Typical Front Hubs and Bearings

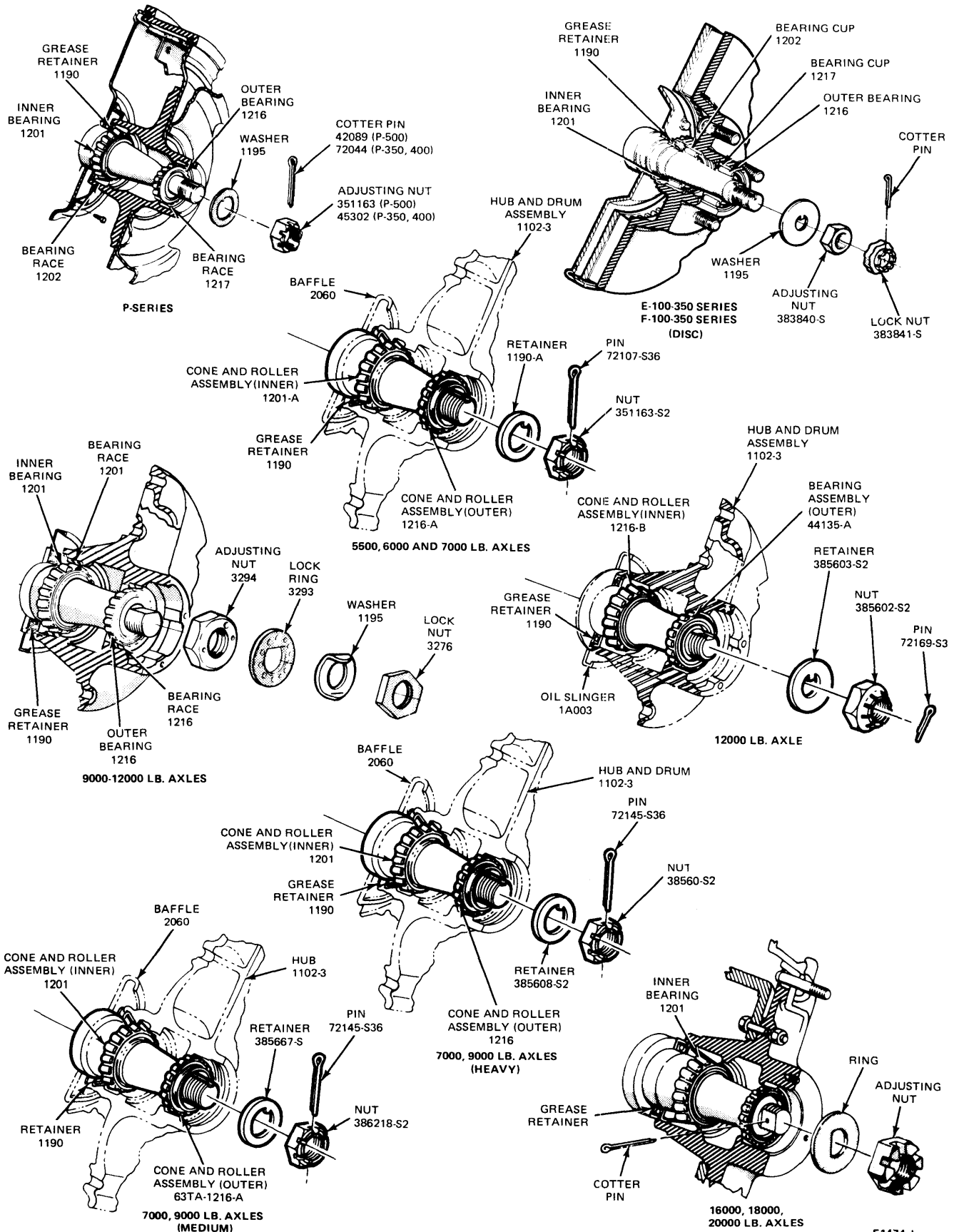

F1474-J

FIG. 2 Front Hubs, Bearings and Grease Retainers

In winter, keep reservoir filled with a solution of two parts water to one part solvent. This helps prevent freezing and damage to the reservoir.

CHECK HEADLIGHT ALIGNMENT

Check the headlights for proper alignment. If necessary, align the headlights using the Headlight Aiming

Kit—Model T.R.E 540 or equivalent. Be sure to use the latest manufacturers instructions.

Body

**PART
50-41**

APPLIES TO ALL MODELS

SUBJECT	PAGE	SUBJECT	PAGE
PRE-DELIVERY		LUBRICATION	
After Road Test	41-1	Cab Latch Mechanism (C-Series)	41-2
Check Bumpers and Mouldings	41-1	Lock and Pivot Points	41-2
Check Doors, Locks and Latches	41-1	MAINTENANCE	
Check Exterior For Fit and Appearance	41-1	Clean Body and Door	
Check Front Bumper Bolt Torque	41-1	Drain Holes	41-2
Check Seat Control	41-1	SPECIFICATIONS	41-2
Check Seatback Latches	41-1		
Check Tailgate Operation	41-1		
Check Windows and Vents	41-1		
Clean and Inspect Vehicle	41-1		
Remove Shipping Protective Material	41-1		

PRE-DELIVERY

CHECK SEAT CONTROL

Check lever operation and test freeness of seat movement on track and solid lock in detent when lever is released. If equipped with suspension seat, check for proper functioning of all controls.

CHECK SEATBACK LATCHES

Be sure latches operate properly and retain seatback.

CHECK WINDOWS AND VENTS

Check ease of operation, matching position of both window handles, and tight fit against weatherstrip. Check for alignment to opening. Refer to 1978 Truck Shop Manual, Group 42, for detailed instructions.

CHECK EXTERIOR FOR FIT AND APPEARANCE

Inspect the body exterior for door and hood gaps or evidence of rubbing or binding with adjacent panels. Check exterior moldings for adequate retention or extreme misalignment. Inspect bumpers for appearance.

CHECK DOORS, LOCKS AND LATCHES

Be sure all doors open, close and lock from both inside and outside the vehicle. Check for proper latching and alignment of latch and striker.

CHECK TAILGATE OPERATION

Lubricate as necessary. Check latch alignment and adjust, if necessary. Refer to 1978 Truck Shop Manual, Group 44, for detailed adjustment procedures.

CHECK BUMPERS AND MOLDINGS

Check condition, fit and alignment. Adjust as required. Refer to the 1978 Truck Shop Manual, Group 47, for detailed instructions.

CHECK FRONT BUMPER BOLT TORQUE

Tighten to specifications given in Specifications Section of this Part.

REMOVE SHIPPING PROTECTIVE MATERIAL

Remove all shipping covers from

vehicle except the tape under the hood flange on L-Series trucks. **This tape should not be removed.**

CLEAN AND INSPECT VEHICLE

Remove the windshield markings and tapes. Wash the vehicle and check for leaks. Inspect metal and paint condition, and touch up chips and scratches. Check for excess sealer. **CAUTION:** Do not use steel wool, abrasive type cleaners, or strong detergents containing highly alkaline or caustic agents on chrome plated materials, aluminum wheels, or anodized aluminum parts because the protective coating may be damaged and discoloration or paint deterioration.

AFTER ROAD TEST

Remove seat protector and tapes. Inspect interior paint condition, and touch up chips and scratches. Check for soft trim soilage and excess sealer.

Check information on ownercard with warranty plate and be sure Owner's Manual is in glove compartment.

LUBRICATION

LOCK AND PIVOT POINTS

To eliminate any binding conditions on pivot and friction points, spray polyethylene grease on hood hinges, auxiliary catch and latch; door hinges, hinges check, rotor and striker plate; and on the tailgate hinges. Operate all pivot points several times to be sure lubricant has been worked in.

Also, apply lock lubricant to the lock cylinders, including the ignition lock, and

insert and turn key several times to work in the lubricant.

See Part 50-03 for lubricant specifications.

CAB LATCH MECHANISM (C-SERIES)

Lubricate the lock handle linkage and locking cams with 10W oil at all pivot points. Operate the mechanism to work the lubricant into all points.

MAINTENANCE

CLEAN BODY AND DOOR DRAIN HOLES

Drain holes, located along the bottom surface of the door and side panels,

should be inspected periodically for obstructions. A practical time for inspection is whenever vehicle is washed.

Use a small screwdriver or similar tool to clean drain holes.

SPECIFICATIONS

FRONT BUMPER BOLTS TORQUE

3/8 Inch	30-40 Ft-Lbs.
7/16 Inch	50-70 Ft-Lbs.
9/16 Inch	80-90 Ft-Lbs.
1/2 Inch	75-105 Ft-Lbs.
5/8 Inch	140-180 Ft-Lbs.

CY 1375-B

DECIMAL AND METRIC EQUIVALENTS

Fractions	Decimal In.	Metric MM.	Fractions	Decimal In.	Metric MM.
1/64	.015625	.39688	33/64	.515625	13.09687
1/32	.03125	.79375	17/32	.53125	13.49375
3/64	.046875	1.19062	35/64	.546875	13.89062
1/16	.0625	1.58750	9/16	.5625	14.28750
5/64	.078125	1.98437	36/64	.578125	14.68437
3/32	.09375	2.38125	19/32	.59375	15.08125
7/64	.109375	2.77812	39/64	.609375	15.47812
1/8	.125	3.1750	5/8	.625	15.87500
9/64	.140625	3.57187	41/64	.640625	16.27187
5/32	.15625	3.96875	21/32	.65625	16.66875
11/64	.171875	4.36562	43/64	.671875	17.06562
3/16	.1875	4.76250	11/16	.6875	17.46250
13/64	.203125	5.15937	45/64	.703125	17.85937
7/32	.21875	5.55625	23/32	.71875	18.25625
15/64	.234375	5.95312	47/64	.734375	18.65312
1/4	.250	6.35000	3/4	.750	19.05000
17/64	.265625	6.74687	49/64	.765625	19.44687
9/32	.28125	7.14375	25/32	.78125	19.84375
19/64	.296875	7.54062	51/64	.796875	20.24062
5/16	.3125	7.93750	13/16	.8125	20.63750
21/64	.328125	8.33437	53/64	.828125	21.03437
11/32	.34375	8.73125	27/32	.84375	21.43125
23/64	.359375	9.12812	55/64	.859375	21.82812
3/8	.375	9.52500	7/8	.875	22.22500
25/64	.390625	9.92187	57/64	.890625	22.62187
13/32	.40625	10.31875	29/32	.90625	23.01875
27/64	.421875	10.71562	59/64	.921875	23.41562
7/16	.4375	11.11250	15/16	.9375	23.81250
29/64	.453125	11.50937	61/64	.953125	24.20937
15/32	.46875	11.90625	31/32	.96875	24.60625
31/64	.484375	12.30312	63/64	.984375	25.00312
1/2	.500	12.70000	1	1.00	25.40000

METRIC-ENGLISH CONVERSION TABLE

Multiply	by	to get equivalent number of:	Multiply	by	to get equivalent number of:
LENGTH			ACCELERATION		
Inch	25.4	millimetres (mm)	Foot/sec ²	0.304 8	metre/sec ² (m/s ²)
Foot	0.304 8	metres (m)	Inch/sec ²	0.025 4	metre/sec ²
Yard	0.914 4	metres	TORQUE		
Mile	1.609	kilometres (km)	Pound-inch	0.112 98	newton-metres (N-m)
AREA			Pound-foot	1.355 8	newton-metres
Inch ²	645.2	millimetres ² (mm ²)	POWER		
	6.45	centimetres ² (cm ²)	Horsepower	0.746	kilowatts (kW)
Foot ²	0.092 9	metres ² (m ²)	PRESSURE OR STRESS		
Yard ²	0.836 1	metres ²	Inches of water	0.249 1	kilopascals (kPa)
VOLUME			Pounds/sq. in.	6.895	kilopascals
Inch ³	16 387.	mm ³	ENERGY OR WORK		
	16.387	cm ³	BTU	1 055.	joules (J)
	0.016 4	litres (l)	Foot-pound	1.355 8	joules
Quart	0.946 4	litres	Kilowatt-hour	3 600 000.	joules (J = one W's)
Gallon	3.785 4	litres		or 3.6 x 10 ⁶	
Yard ³	0.764 6	metres ³ (m ³)	LIGHT		
MASS			Foot candle	1.076 4	lumens/metre ² (lm/m ²)
Pound	0.453 6	kilograms (kg)	FUEL PERFORMANCE		
Ton	907.18	kilograms (kg)	Miles/gal	0.425 1	kilometres/litre (km/l)
Ton	0.907	tonne (t)	Gal/mile	2.352 7	litres/kilometre (l/km)
FORCE			VEL		
Kilogram	9.807	newtons (N)	Miles/hour	1.60	
Ounce	0.278 0	newtons			
Pound	4.448	newtons			
TEMPERATURE					
Degree Fahrenheit	(+°F-32)÷ 1.8	degree Celsius			

Buy Now

