

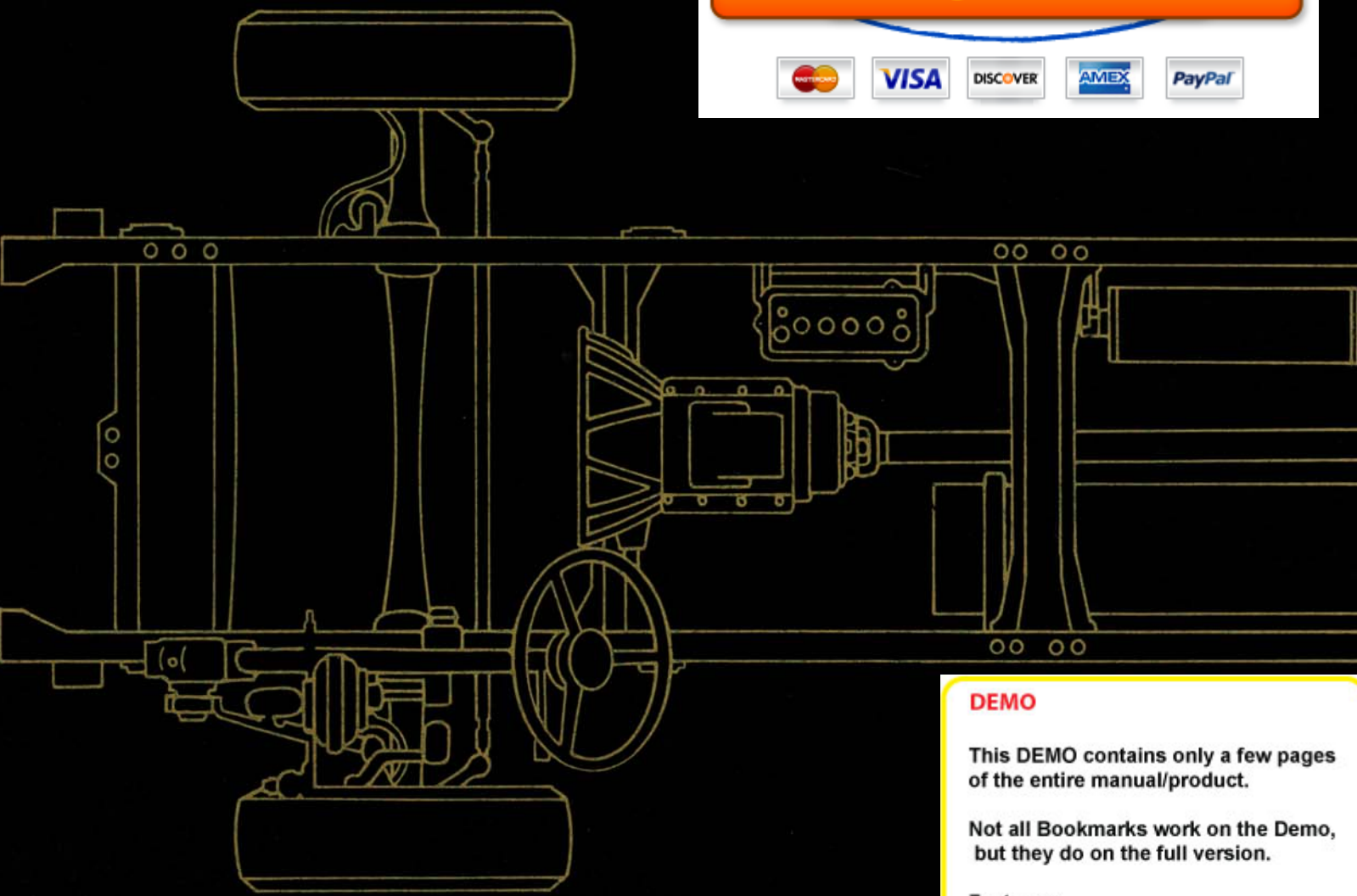

# 1974 TRUCK SHOP MANUAL

**Buy Now**



## Complete 5 Volume Set

Volume 1 - Chassis

Volume 2 - Engine

Volume 3 & 4 - Body and Electrical

Volume 5 - Maintenance and Lubrication

**DEMO**

This DEMO contains only a few pages of the entire manual/product.

Not all Bookmarks work on the Demo, but they do on the full version.

Features:

- Searchable text
- Printable pages
- Bookmarked for easy navigation
- High Resolution images
- Zoom to see exact details
- Money back Guarantee
- Transfer to USB flash drive support



License #2011/74

Copyright © 2012, Forel Publishing Company, LLC, Woodbridge, Virginia

All Rights Reserved. No part of this book may be used or reproduced in any manner whatsoever without written permission of Forel Publishing Company, LLC. For information write to Forel Publishing Company, LLC, 3999 Peregrine Ridge Ct., Woodbridge, VA 22192

## **1974 Ford Truck Shop Manual**

**EAN: 978-1-60371-082-4**

**ISBN: 1-60371-082-5**

Forel Publishing Company, LLC

3999 Peregrine Ridge Ct.

Woodbridge, VA 22192

Email address: [sales@ForelPublishing.com](mailto:sales@ForelPublishing.com)

Website: <http://www.ForelPublishing.com>



This publication contains material that is reproduced and distributed under a license from Ford Motor Company. No further reproduction or distribution of the Ford Motor Company material is allowed without the express written permission of Ford Motor Company.

---

## **Note from the Publisher**

This product was created from the original Ford Motor Company's publication. Every effort has been made to use the original scanned images, however, due to the condition of the material; some pages have been modified to remove imperfections.

---

## **Disclaimer**

Although every effort was made to ensure the accuracy of this book, no representations or warranties of any kind are made concerning the accuracy, completeness or suitability of the information, either expressed or implied. As a result, the information contained within this book should be used as general information only. The author and Forel Publishing Company, LLC shall have neither liability nor responsibility to any person or entity with respect to any loss or damage caused, or alleged to be caused, directly or indirectly by the information contained in this book. Further, the publisher and author are not engaged in rendering legal or other professional services. If legal, mechanical, electrical, or other expert assistance is required, the services of a competent professional should be sought.

---



# 1974 TRUCK SHOP MANUAL

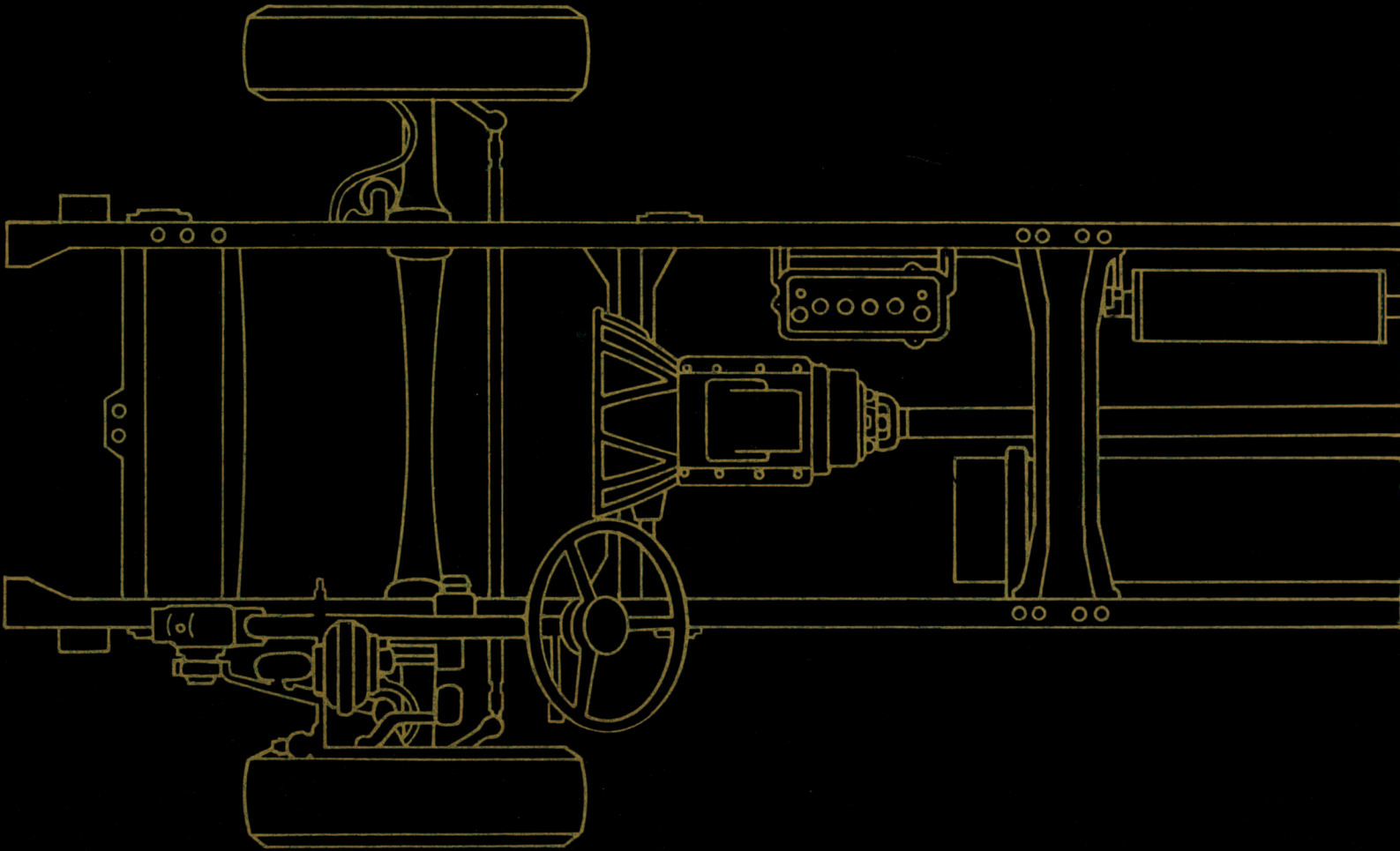

**Volume 1**

# **Chassis**

Second Printing

# Group Index

# 1974 TRUCK SHOP MANUAL

## Volume I Chassis

Identification Codes	10
Wheels and Tires	11
Brakes	12
Steering	13
Suspension	14
Driving Axles and Drive Shafts	15
Clutch and Manual Transmission	16
Automatic Transmission	17

### Vol. II

Vehicle Identification	20
Gasoline Engines	21
Diesel Engines	22
Ignition System	23
Fuel System—Gasoline	24
Fuel System—Diesel	25
Exhaust System	26
Cooling System	27
Starting System	28
Emissions Controls	29

### Vol. III & IV

Identification Codes	30
Charging System	31
Lighting System	32
Instruments, Clusters and Controls	33
Main Wiring Harnesses and Circuit Protection	34
Auxiliary Equipment	35
Ventilating, Heating and Air Conditioning	36
Seats	41
Window Glass and Mechanisms	42
Stationary Window Glass	43
Doors, Hood & Tailgate	44
Interior Trim	45
Tops	46
Body Shell, Exterior Trim, Frame & Underbody	47

### Vol. V

Maintenance and Lubrication	50
-----------------------------	----



## FOREWORD

This manual is divided into five volumes: 1 – Chassis, 2 – Engine, 3 – Electrical, 4 – Body, 5 – Pre-delivery, Maintenance and Lubrication. These volumes provide Service Technicians with complete information covering normal service repairs on all 1974 model vehicles built by the Ford Motor Companies in the U. S. and Canada.

Information in each volume is divided into groups covering a general system. For easy reference, information in each group has been broken into smaller units or parts. There is one part for each component within the system as well as a general service part for information common to several similar components. Page numbers indicate this division.

Example: (Group 11- (Part) 02- (Page) 21

Page numbers are consecutive within each part.

The table of contents on the first page of the volume indicates the groups contained in each of the five volumes, and a tab locator is provided for finding each group of that particular volume. The first page of each group has an index to the smaller parts, and the first page of each part contains an index with page location for each service operation covered.

The descriptions and specifications in this manual were in effect at the time this manual was approved for printing. Ford Marketing Corporation reserves the right to discontinue models at any time, or change specifications or design without notice and without incurring obligation.



Service Publications

# Identification Codes

**GROUP**  
10

## GENERAL INFORMATION

### VEHICLE CERTIFICATION LABEL

The Vehicle Certification Label (V.C. Label) is attached to the rear face of the driver's door. The upper half of the label contains the name of the manufacturer,

the month and year of manufacture and the certification statement. The V.C. Label also contains the Vehicle Identification Number.

The remaining information codes on

the V.C. Label are the same as the Truck Rating Plate Codes (Fig. 1). Vehicle codes shown on the Truck Rating Plate are explained in the following paragraphs.

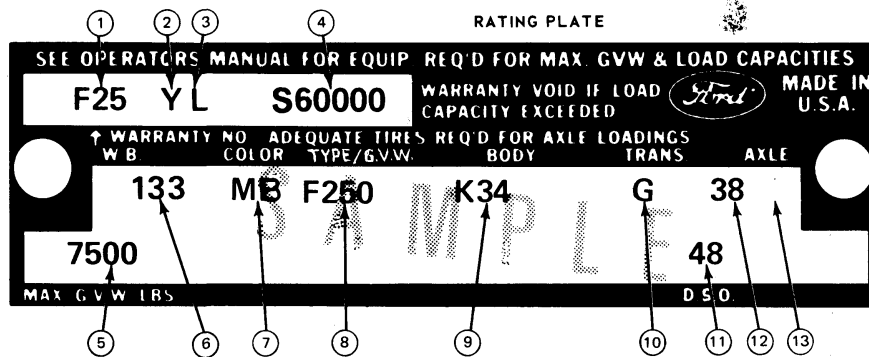

- ① TRUCK SERIES CODE
- ② ENGINE CODE
- ③ ASSEMBLY PLANT CODE
- ④ CONSECUTIVE UNIT NO.
- ⑤ RECOMMENDED MAX. GROSS VEHICLE WEIGHT

- ⑥ WHEELBASE
- ⑦ EXTERIOR PAINT CODES
- ⑧ MODEL CODE
- ⑨ BRONCO, ECONOLINE AND 100-6000 - TRIM CODE; 700-9000 SERIES - FIRST CHARACTER IS CAB TRIM, SECOND IS SEAT TYPE, AND THIRD IS BODY CODE

- ⑩ TRANSMISSION CODES
- ⑪ DISTRICT/SPECIAL ORDER CODES
- ⑫ REAR AXLE CODES
- ⑬ FRONT AXLE CODES (IF SO EQUIPPED)

FIG. 1 Typical Truck Rating Plate and Vehicle Certification Label

### RATING PLATE

Fig. 1 illustrates a typical Truck Rating Plate. On light and medium cowl and windshield vehicles, the Rating Plate is mounted on the right side of the cowl top panel under the hood. On stripped Parcel Delivery vehicles, the rating plate is placed in an envelope and included in the Boxed Items parts. On Bronco models, the plate is mounted on the inside panel of the glove compartment door. On all other vehicles, the Rating Plate is mounted on the rear face of the left front door.

### VEHICLE IDENTIFICATION NUMBER

The identification number is the first line of numbers and letters appearing on

the Rating Plate (Fig. 1). The first letter and two numbers indicate the truck model and series (the letter prefix identifies the type of body or cab and the numbers are the first two numbers of a truck series). The letter following the truck series code designates the engine identification code. The letter following the engine identification code indicates the assembly plant at which the vehicle was built. The remaining numbers indicate the consecutive unit number. The charts that follow list the various vehicle identification number codes.

### VEHICLE DATA

The Vehicle Data appears on the Rating Plate on the two lines following the identification number. The first three

digits under W.B. designate the wheelbase in inches. The one or two letters under COLOR identify the exterior paint color (two letters designate a two-tone). The letter and three digits under TYPE/G.V.W. designate the truck model within a series. The letter and numerals under BODY designate the interior trim and body type (the letter identifies the interior trim scheme and the numerals identify the body or cab type). The transmission installed in the vehicle is identified under TRANS by either a numeric or alphabetical code (if two symbols appear, the first identifies the auxiliary transmission, if so equipped, and the second symbol identifies the main transmission). A letter and a number or two numbers under AXLE identify the

rear axle ratio (when required, a letter is also stamped behind the rear axle code to identify the front axle capacity). The maximum gross vehicle weight in pounds is stamped under MAX. G.V.W.

A two-digit number is stamped under D.S.O. to identify the district which ordered the vehicle. If the vehicle is built to special order (Domestic Special Order, Foreign Special Order, Limited Production Option, or other special order), the complete order number will

also appear under D.S.O. The charts that follow list the various vehicle data codes.

**W.B. (WHEELBASE)**

The wheelbase in inches is entered in this space.

**MAX. G.V.W. LBS**

The maximum gross vehicle weight in pounds is recorded in this space.

**D.S.O.**

If vehicle is built on a D.S.O., F.S.O., L.P.O. (special orders) the complete order number will be reflected under the D.S.O. space including the District Code Number.

**MODEL DESIGNATION (FIRST 3 CODE SYMBOLS--  
WARRANTY SERIAL NO. LINE)**

U	Bronco	F-26	F-28	F-250 4x4	K-80	L-8000	(Diesel)
	Basic Series	F-35	F-37	F-350	K-81	L-8000	
U-15	U-100 (Wagon) 4 x 4		F-50	F-500	K-90	L-9000	
E	Econoline		F-60	F-600	N-60	N-600	
	Basic Series		F-61	F-600	N-61	N-600	
	100 Series		F-65, 4 x 4	F-600	N-70	N-700	(Gas)
E-11	E-100 Club Wagon		F-66, 4 x 4	F-600	N-75	N-750	
E-14	E-100 Regular Van		F-70	F-700	N-80	N-800	
E-15	E-100 Window Van		F-75	F750	N-90	N-900	
E-16	E-100 Display Van		F-60	F-6000	R-60	N-6000	
	200 Series		K-61	F-6000	R-61	N-6000	
E-21	E-200 Club Wagon		K-70	F-7000	R-70	N-7000	(Diesel)
E-22	E-200 Custom Club Wagon				R-80	N-8000	
E-23	E-200 Chateau Wagon	B	Bus	(Gas)	R-81	N-8000	
E-24	E-200 Regular Van	B-50	B-500		R-90	N-9000	
E-25	E-200 Window Van	B-60	B-600		S-80	NT-800	
E-26	E-200 Display Van	B-61	B-600		S-90	NT-900	(Gas)
	Bus Models	B-70	B-700		W-80	NT-8000	
E-30	"Cutaway" Camper	B-75	B-750		W-90	NT-9000	(Diesel)
	300 Series	J-70	B-7000	(Diesel)	C-60	C-600	
E-31	E-300 Club Wagon				C-61	C-600	
E-32	E-300 Custom Club Wagon	P	Parcel	(Gas)	C-70	C-700	(Gas)
E-33	E-300 Chateau Wagon	G	Parcel	(Diesel)	C-75	C-750	
E-34	E-300 Regular Van	P-35	P-350		C-80	C-800	
E-35	E-300 Window Van	P-40	P-400		C-90	C-900	
E-36	E-300 Display Van	P-50	P-500		D-60	C-6000	
	Bus Models	P-60	P-600	(DSO)	D-70	C-7000	(Diesel)
V-80	LTS 800	G-50	P-5000	(DSO) (Diesel)	D-80	C-8000	
V-90	LTS 900				T-80	LT-800	
					T88	LT-880	
F	Conventional				T-90	LT-900	(Gas)
					U-80	LT-8000	
K	Conventional				U-90	LT-9000	(Diesel)
	Chassis				L-80	CT-800	
Pick-up	Cab				L-90	CT-900	(Gas)
F-10	F-17	F-100			Q-80	CT-8000	(Diesel)
F-11	F-18	F-100 4x4			Z-90	W-9000	
F-25	F-27	F-250			X-90	WT-9000	(Diesel)

ENGINE CODES BRONCO-ECONO-CLUB WAGONS-PARCEL-SCHOOL BUS-LT & MED TRUCKS			
Code		CID Engine	Cyl.
T	Gas (Bronco)	200-1V	6
G		302-2V	8
A	Gas (Econoline)	240-1V	6
G		302-2V	8
B		300-1V	6
A	Gas (F100-250-350)	240-1V	6
B		300-1V	6
G		302-2V	8
Y		360-2V	8
H		390-2V	8
J		460-4V	8
B	Gas (600 Series)	Medium 300-1V	6
B		300-1V H.D.	6
C		330-2V	8
D		330-2V H.D.	8
E		361-2V	8
K		359-2V (DSO)	8
U		Diesel (CAT) 522 (V 150)	8
V	(CAT) 522 (V 175)	8	
W	DORSET (DSO) 380	6	
B	Gas (Parcel Delivery)	300-1V	6
1	Gas (Low Compression Export)	240-1V	6
4		330-2V H.D.	8
8		360-2V	8
5		361-2V	8
Heavy and Extra Heavy Truck-Series 700 through 9000 LN 500-9000 and C-500-900			
Code	Cylinders	Engine C.I.D.	
D	8	330" 2V H.D	
4	6	330" 2V H.D. Low Comp.	
E	8	361" 2V	
5	8	361" 2V Low Comp.	
F	8	391" 4V	
H	8	401" 4V	
K	8	477" 4V	
L	8	534" 4V	
U	8	330" 2V H.D.-LPG (DSO)	
W	8	361" 2V-LPG (DSO)	
9	8	534" 4V-LPG (DSO)	
X	8	391" 4V-LPG (DSO)	
J	6	300" 2V-LPG (DSO)	
J	8	475" 4V	
MOTOR HOME (DSO)			
Y	8	360-2V	
H	8	390-2V	
ASSEMBLY PLANTS CODE LETTERS			
Code	Assembly Plant		
C	Ontario Truck		
E	Mahwah		
H	Lorain		
I	Highland Park		
K	Kansas City		
L	Michigan Truck		

AUXILIARY TRANSMISSION CODE

Code	Description	Code	Description
2	Spicer 5831D	5	Spicer 8341C
3	Spicer 7231B	6	Spicer 8031C
4	Spicer 7231D	8	Spicer 7041

Heavy and Extra Heavy Truck-Series 700 through 9000 LN 500-9000 and C-500-900		
Code	Engine C.I.D.	
A	555"	Cummins - V8 - 210 HP
B	903"	Cummins - V903 - 320 HP
C	636"	Caterpillar - V8 - 225 HP
D	855"	Cummins - NTC-270CT - 255 HP (DSO)
E	903"	Cummins - V903 - 280 HP
F	855"	Cummins - NTC-270CT - 240 HP (DSO)
G	903"	Cummins - V903 - 300 HP
J	855"	Cummins - NHC-250 - 250 HP - 2100 RPM
K	855"	Cummins - NTC-270CT - 270 HP
L	855"	Cummins - NTC-335 - 350 HP
K	159"	Detroit - 3V-53N - 94 HP - 2800 RPM (DSO)
N	855"	Cummins - NTC-335 - 280 HP
P	855"	Cummins - NTC-335 - 300 HP
Q	855"	Cummins - NTC-335 - 320 HP
R	855"	Cummins - NTC-335 - 355 HP
T	568"	Detroit - 8V-71N - 318 HP - 2100 RPM
U	568"	Detroit - 8V-71N - 350 HP - 2300 RPM
U	522"	Caterpillar - V8 - 150 HP
V	522"	Caterpillar - V8 - 175 HP
V	855"	Cummins - NTC-290 - 290 HP - 2100 RPM
W	855"	Cummins - NTC-290 - 270 HP - 2100 RPM
X	927"	Cummins - Super 250 - 250 HP - 2100 RPM
Y	927"	Cummins - Super 250 - 270 HP - 2100 RPM (DSO)
S	568"	Detroit - 8V-71N - 270 HP - 2100 RPM (DSO)
A	555"	Cummins - V8 - 210 HP
H	555"	Cummins - V8 - 225 HP
1	855"	Cummins - NH-230 - 230 HP - 2100 RPM
2	426"	Detroit - 6-71N - 238 HP - 2100 RPM
3	638"	Caterpillar - 1674 - 270 HP (DSO)
4	426"	Detroit - 6-71NE - 195 HP - 2100 RPM (DSO)
4	573"	Caterpillar - V8 - 200 HP
5	855"	Cummins - NTC-290 - 270 HP - 1950 RPM
6	568"	Detroit - 8V-71N - 290 HP - 2100 RPM
7	568"	Detroit - 8V-71NE - 260 HP - 1950 RPM
8	318"	Detroit - 6V-53N - 195 HP - 2600 RPM
9	855"	Cummins - NTC-290R - 300 HP - 2100 RPM (DSO)

1973 CALENDAR YEAR PRODUCTION

Month	Bronco, E100-E300, F100-F350 F-B 500-600-6000	Parcel-Heavy Extra-Heavy Series
August	\$60,000-\$79,999	\$65,000-\$79,999
September	\$80,000-\$99,999	\$85,000-\$99,999
October	T00,000-T19,999	T05,000-T19,999
November	T20,000-T39,999	T25,000-T39,999
December	T40,000-T59,999	T45,000-T59,999

1974 CALENDAR YEAR PRODUCTION

Month	Bronco, E100-E300, F100-F350 F-B 500-600-6000	Parcel-Heavy Extra-Heavy Series
January	T60,000-T79,999	T65,000-T79,999
February	T80,000-T99,999	T85,000-T99,999
March	U00,000-U19,999	U05,000-U19,999
April	U20,000-U39,999	U25,000-U39,999
May	U40,000-U59,999	U45,000-U59,999
June	U60,000-U79,999	U65,000-U79,999
July	U80,000-U99,999	U85,000-U99,999

ASSEMBLY PLANTS CODE LETTERS

Code	Assembly Plant
N	Norfolk
P	Twin Cities
R	San Jose
S	Allen Park
U	Louisville
V	Kentucky Truck



EXTERIOR PAINT COLOR CODES

Code	Color	M-30J/M-32J Spec. No.	Code	Color	M-30J/M-32J Spec. No.
A	Black	1724-A	V	Med. Beige	5251-A
B	Lt. Blue	3429-A	W	Lt. Ginger Met.	3516-HS
C	Spec. White	1525-A	X	Lt. Grabber Blue	5226-A
D	Lt. Yellow	3439-A	Y	Orange	5296-A
E	Med. Blue Met.	5087-A	Z	Lt. Copper Met.	5035-A
F	Lt. Green	5058-A	2	Pastel Lime	5023-A
G	Chrome Yellow	1526-A	3	Bright Green	5232-A
H	Med. Beige	3569-A	4	Bright Lime	5027-A
J	Rangoon Red	1515-A	5	Med. Orange Yellow	5148-A
K	Med. Ivy Green	3150-A	6	Br. Med. Blue	5004-A
L	Dk. Green	1237-A	7	Med. Blue	2099-A
M	White	1619-A	7	Br. Yellow Gold Met.	5079-A
N	Bright Green Met.	5396-A	8	Dark Yellow	5043-A
P	Med. Green Met.	3462-A	9	Prime Red	M6J102-B
R	Ginger Met.	5186-A		Prime Gray	M6J103-B
S	Br. Dk. Blue Met.	5094-A			
T	Red	2008-A			
U	Med. Line Met.	5021-A			

CLUB WAGON INTERIOR TRIM CODES

13, 14, 15	Lt. Gray/Black Vinyl
23, 24, 25	Lt. Blue/Med. Blue Vinyl or Cloth and Vinyl
33, 34, 35	Lt. Ginger/Med. Ginger Vinyl or Cloth and Vinyl
43, 44, 45	Lt. Green/Med. Green Vinyl or Cloth and Vinyl
23, 24, 25	Lt. Blue/Med. Blue Vinyl or Cloth and Vinyl
33, 34, 35	Lt. Ginger/Med. Green Vinyl or Cloth and Vinyl
43, 44, 45	Lt. Green/Med. Green Vinyl or Cloth and Vinyl
23, 24, 25	Med. Blue Vinyl or Cloth and Vinyl
33, 34, 35	Med. Ginger Vinyl or Cloth and Vinyl
43, 44, 45	Med. Ginger Vinyl or Cloth and Vinyl

ECONOLINE INTERIOR TRIM CODES

1, 11, 12	Lt. Gray/Black Vinyl
2, 21, 22	Lt. Blue/Med. Blue Vinyl
3, 31, 32	Lt. Ginger/Med. Ginger Vinyl
4, 41, 42	Lt. Green/Med. Green Vinyl
26, 27, 28	Lt. Blue/Med. Blue Vinyl
36, 37, 38	Lt. Ginger/Med. Ginger Vinyl
46, 47, 48	Lt. Green/Med. Green Vinyl
B, B7, B8	Lt. Blue/Med. Blue Vinyl
C, C7, C8	Lt. Ginger/Med. Ginger Vinyl
D, D1, D2	Lt. Green/Med. Green Vinyl
B, B1, B2	Lt. Blue/Med. Blue Vinyl
C, C1, C2	Lt. Ginger/Med. Ginger Vinyl
D, D1, D2	Lt. Green/Med. Green Vinyl
K, K1, K2	Lt. Blue/Med. Blue Vinyl
L, L1, L2	Lt. Ginger/Med. Ginger Vinyl
M, M1, M2	Lt. Green/Med. Green Vinyl
S, S1, S2	Med. Blue Vinyl
T, T1, T2	Med. Ginger Vinyl
U, U1, U2	Med. Green Vinyl

HEAVY TRUCK TRIM CODES

4, 4B, 43, D, DB, 4A, DA, 46, 4F, D6, DF, 4C, D3, DC	Black Vinyl
23, B	Med. Blue Vinyl
53, E	Red/Dk. Red Vinyl
33, C, 32, C1	Lt. Med./Ginger Vinyl
63, F	Med. Green Vinyl
BB, BA	Black W/Blue Vinyl
EB, EA	Black W/Red Vinyl
CB, CA	Black W/Ginger Vinyl
FB, FA	Black W/Green Vinyl
41, 42, D1	Black Met.

LIGHT AND MEDIUM TRUCK TRIM CODES

4, 43, D3, M3, D	Black Met.
5	Red/Dk. Red Vinyl
6	Lt./Med. Green Vinyl
2	Lt./Med. Blue Vinyl
4B, DB, MB	Black Vinyl
5B, EB, NB	Black W/Red Vinyl
6B, FB, DB	Black W/Green Vinyl
2B, BB, KB	Black W/Blue Vinyl
3B*, CB, LB	Black W/Ginger Vinyl
23, B3, K3, B	Med. Blue Met.
53, E3, N3, E	Red/Dk. Red Met.
33, C3, L3	Lt./Med. Ginger Vinyl
63, F3, O3	Med. Green Met.
D, M	Black/Black Met.
B	Med. Blue/Med. Blue Met.
E, N	Dk. Red/Dk. Red Met.
C	Med. Ginger Vinyl
G, G3, P3	Med./Lt. Avocado
F, O	Med. Green/Med. Green Met.
GB, PB	Black W/Avocado
K	Med. Blue/Blue Met.
L	Med. Ginger/Med. Ginger Met.-Med. Ginger
P	Med. Avocado/Lt. Avocado Met.-Lt. Avocado

\*Requires Knit Vinyl Opt.

BRONCO INTERIOR TRIM CODES

3, 34*	Pastel Parchment Vinyl
B, B4*	Med. Blue Vinyl
C, C4*	Med. Ginger Vinyl
G, G4*	Med./Lt. Avocado Vinyl

\*When Rearseat is Installed

**RATING PLATE "BODY" TYPE CODE  
ECONOLINE-VANS & CLUB WAGONS**

CUSTOM	STANDARD	CAB/TRIM	VAN SEATS		WAGON SEATS	
-	1	GRAY/BLACK	1	STATIONARY PASSENGER	3	FIRST & SECOND ROW - 5 PASSENGER
B	2	BLUE	2	FLIP PASSENGER	4	FIRST, SECOND & THIRD ROW - 8 PASSENGER
C	3	GINGER	6	DELUXE DRIVER	5	FIRST, SECOND, THIRD & FOURTH ROW - 12 PASSENGER
D	4	GREEN	7	DELUXE DRIVER & DELUXE STATIONARY PASSENGER		
			8	DELUXE DRIVER & FLIP PASSENGER		

E300 CUTAWAY		
CUSTOM	DELUXE	CHATEAU
B	K	S
C	L	T
D	M	U

**LIGHT & MEDIUM TRUCK - 100 Thru 6000 and Bronco**

RANGER/ CUSTOM	EXPLORER	RANGER XLT	STD.	COLOR CAB/TRIM
*B	S	K	2	BLUE
*C	T	L	3	PARCHMENT GINGER
D		M	4	BLACK
E		N	5	RED
F		O	6	GREEN
*G		P		AVOCADO VERMILLION TAN
	V			
	Z			

H.D. VINYL	STANDARD	SEATS
B	-	BENCH SEAT
-	3	KNITTED VINYL COMFORT
-	4	BRONCO REAR SEAT

\*ALSO BRONCO DRESS UP OPTION

BODY TYPE	
3	FLARESIDE PICK-UP
4	STYLESIDE PICK-UP
5	PLATFORM STAKE
7	COWL
8	CHASSIS CAB
9	PLATFORM
D	STYLESIDE PICK-UP CREW
G	CHASSIS CREW CAB
M	SUPER CAB STYLESIDE PICK-UP

Seat Type - Medium and Heavy Truck				Description
HD Black Vinyl	Driver w/Passenger	Single Driver	Bench	
A	-	-	1	Bench Seat
B	-	-	2	Custom Bench Seat
-	C	3	-	L-S Unison
-	D	4	-	L-S No. 675
-	E	5	-	Bostrom Westcoaster
-	F	6	-	Bostrom T-Bar
-	G	7	-	National Cush-N-Aire
-	H	8	-	Bostrom Level Air

**HEAVY TRUCK**

**F & B 500-600 (6000)**

CUSTOM	STANDARD	CAB/TRIM	CUSTOM	STANDARD
A	1	GRAY	B	2
B	2	BLUE	C	3
C	3	GINGER	D	4
D	4	BLACK	E	5
E	5	RED	F	6
F	6	GREEN		
G	-	SADDLE		

**BODY TYPE**

ALUMINUM STEEL		
CAB	SLEEPER	SLEEPER
-	-	-
-	-	-
-	-	-
H	Q	Y
-	-	-
-	-	-

**FRONT AXLE CODES LIGHT AND MEDIUM TRUCKS**

W/POWER STEERING	CODE	FRONT AXLE/ POWER STEERING
J	-	POWER STEERING
K	2	5,500
L	3	6,000
M	4	7,000
P	7	3,500 DANA-60F
Q	8	3,000 DANA-44-LOCKING

**HEAVY TRUCKS WITH POWER STEERING**

J	1	5,000
K	2	5,500
L	3	6,000
M	4	7,000
N	5	9,000
-	6	12,000 CENTER POINT
P	7	12,000
-	8	12,000 STEER EASE
R	9	15,000
S	-	16,000
T	-	18,000
U	-	20,000
Z	-	DSO FRONT AXLE
A		3,800 PARCEL
B		4,700 PARCEL

**DISTRICT CODES**

11	BOSTON	53	KANSAS CITY
12	BUFFALO	54	OMAHA
13	NEW YORK	55	ST. LOUIS
14	PITTSBURGH	56	DAVENPORT
15	NEWARK	57	HOUSTON
16	PHILADELPHIA	58	TWIN CITIES
17	WASHINGTON	71	LOS ANGELES
21	ATLANTA	72	SAN JOSE
22	CHARLOTTE	73	SALT LAKE CITY
23	MEMPHIS	74	SEATTLE
24	JACKSONVILLE	75	PHOENIX
25	RICHMOND	76	DENVER
26	NEW ORLEANS	83	GOVERNMENT
28	LOUISVILLE	84	HOME OFFICE RESERVE
41	CHICAGO	85	AMERICAN RED CROSS
42	CLEVELAND	89	TRANSPORTATION SERVICES
43	MILWAUKEE	87	BODY COMPANY
45	LANSING	90's	EXPORT
46	INDIANAPOLIS		
47	CINCINNATI		
48	DETROIT		
52	DALLAS		

**FORD OF CANADA**

MERCURY REGIONS	
A1	CENTRAL
A2	EASTERN
A3	ATLANTIC
A4	MIDWESTERN
A6	WESTERN
A7	PACIFIC
FORD REGIONS	
B1	CENTRAL
B2	EASTERN
B3	ATLANTIC
B4	MIDWESTERN
B6	WESTERN
B7	PACIFIC

NOTE: EXPORT ALPHABETICAL I

**TANDEM REAR AXLE CODES**

Code	Description	Capacity	Ratio	Code	Description	Capacity	Ratio	Code	Description	Capacity	Ratio
AJ	Eaton 38DSC	(38,000)	4.56	ER	Eaton 38DPC	(38,000)	6.65	B9	Rockwell SLHD	(34,000)	7.80
BJ	Eaton 38DSC	(38,000)	4.88	FR	Eaton 38DPC	(38,000)	7.60	DA	Rockwell SQHD	(38,000)	6.17
CJ	Eaton 38DSC	(38,000)	5.57	AV	Eaton 42DPB	(44,000)	7.60	D1	Rockwell SQHD	(38,000)	4.11
FJ	Eaton 38DSC	(38,000)	4.11	CV	Eaton 42DPB	(44,000)	5.05	D2	Rockwell SQHD	(38,000)	4.44
GJ	Eaton 38DSC	(38,000)	4.33	DV	Eaton 42DPB	(44,000)	5.91	D3	Rockwell SQHD	(38,000)	4.63
HJ	Eaton 38DSC	(38,000)	5.29	BA	Rockwell SLHD	(34,000)	3.55	D4	Rockwell SQHD	(38,000)	5.29
DJ	Eaton 38DSE	(38,000)	6.14	BB	Rockwell SLHD	(34,000)	8.60	D5	Rockwell SQHD	(38,000)	5.83
EJ	Eaton 38DSE	(38,000)	6.50	B1	Rockwell SLHD	(34,000)	4.11	D6	Rockwell SQHD	(38,000)	6.83
JJ	Eaton 38DSE	(38,000)	7.17	B2	Rockwell SLHD	(34,000)	4.44	D7	Rockwell SQHD	(38,000)	7.80
KJ	Eaton 38DSE	(38,000)	7.60	B3	Rockwell SLHD	(34,000)	4.63	D8	Rockwell SQHD	(38,000)	4.88
DN	Eaton 34DPC	(34,000)	6.21	B4	Rockwell SLHD	(34,000)	4.88	AX	Eaton 50DP	(50,000)	5.61
FN	Eaton 34DPC	(34,000)	7.60	B6	Rockwell SLHD	(34,000)	5.83				
AR	Eaton 38DPC	(38,000)	5.05	B7	Rockwell SLHD	(34,000)	6.17				
DR	Eaton 38DPC	(38,000)	6.22	B8	Rockwell SLHD	(34,000)	6.83				

**FORD TRUCK SERIES DESIGNATIONS**

Prefix	Series Numbers	Series	Prefix	Series Numbers	Series
U	100	Bronco	C	500 thru 900	Tilt Cab-Gas
E	100 thru 300	Econoline Van	C	6000 thru 8000	Tilt Cab-Diesel
F	100 thru 750	Conventional-Gas	CT	800 and 900	Tilt Cab Tandem-Gas
F	6000 and 7000	Conventional-Diesel	CT	8000	Tilt Cab Tandem-Diesel
L	800 and 900	Conventional-Gas	W	9000	Hi-Tilt Tractor-Diesel
L	8000 and 9000	Conventional-Diesel	WT	9000	Hi-Tilt Tractor-Diesel
LT	800, 880 and 900	Conventional Tandem-Gas	B	500 thru 750	School Bus Chassis-Gas
LT	8000 and 9000	Conventional Tandem-Diesel	B	7000	School Bus Chassis-Diesel
LTS	800 and 900	46" BA Conventional Tandem-Gas	P	350 thru 500	Parcel Delivery-Gas
LTS	8000 and 9000	46" BA Conventional Tandem-Diesel	*P	600	Parcel Delivery-Gas
N	600 thru 900	95.3" BBC Conventional-Gas	P	5000	Parcel Delivery-Diesel
N	6000 and 7000	95.3" BBC Conventional-Diesel	M	400 thru 505	Motor Home Chassis-Gas
N	8000 and 9000	93.3" BBC Conventional-Diesel			
NT	800, 880 and 900	93.3" BBC Conventional Tandem-Gas			
NT	8000 and 9000	93.3" BBC Conventional Tandem-Diesel			

\*Special Order

**MODEL CODES AND GROSS VEHICLE WEIGHT RATING**

Econoline - Club and Chateau Wagon											
Club				Custom Club				Chateau			
Series	Code	Model	G.V.W.	Series	Code	Model	G.V.W.	Series	Code	Model	G.V.W.
E-100	E-110	5 Passenger	4,800	E-200	E-223	5 Passenger	5,500	E-200	E-233	5 Passenger	5,500
	E-111	5 Passenger	4,900		E-224	5 Passenger	5,700		E-234	5 Passenger	5,700
E-200	E-210	5 Passenger	5,200		E-225	8 Passenger	6,000		E-235	8 Passenger	6,000
	E-213	5 Passenger	5,500	E-300	E-321	5 Passenger	6,800	E-300	E-331	5 Passenger	6,800
	E-211	8 Passenger	5,300		E-324	8 Passenger	6,800		E-334	8 Passenger	6,800
	E-214	5 Passenger	5,700		E-325	12 Passenger	6,800		E-335	12 Passenger	6,800
	E-212	5 Passenger	5,400		E-323	5 Passenger	7,600		E-333	5 Passenger	7,600
	E-216	8 Passenger	5,600		E-322	8 Passenger	7,500		E-332	8 Passenger	7,500
	E-215	5 Passenger	6,000		E-326	12 Passenger	7,600		E-336	12 Passenger	7,600
	E-300	E-310	5 Passenger		6,500	E-327	8 Passenger		7,800	E-337	8 Passenger
E-311		5 Passenger	6,800		E-329	8 Passenger	7,000		E-339	12 Passenger	7,800
E-318		8 Passenger	6,500	<b>Bronco</b>							
E-314		8 Passenger	6,800	<b>Series</b>	<b>Code</b>	<b>Model</b>	<b>G.V.W.</b>	<b>Series</b>	<b>Code</b>	<b>Model</b>	<b>G.V.W.</b>
E-315		12 Passenger	6,800		U-150	Wagon	4,300		U-152	Wagon	4,900
E-313		5 Passenger	7,600		U-151	Wagon	4,500		U-153	Wagon	4,450
E-312		8 Passenger	7,500								
E-316		12 Passenger	7,600								
E-317		8 Passenger	7,800								
E-319		12 Passenger	7,800								

**ECONOLINE MODEL CODES – VAN**

Series	Code	Model	G.V.W.	Series	Code	Model	G.V.W.
E-100	E-140	Van	4,325	E-300 (Contd.)	E-342	Van	6,800
	E-141	Van	4,600		E-343	Van	7,000
	E-142	Van	4,800		E-344	Van	7,500
	E-150	Window	4,325		E-345	Van	7,700
	E-151	Window	4,600		E-346	Van	8,300
	E-152	Window	4,800		E-350	Window	6,050
	E-160	Display	4,325		E-351	Window	6,200
	E-161	Display	4,600		E-352	Window	6,800
	E-162	Display	4,800		E-353	Window	7,000
E-200	E-240	Van	5,250		E-354	Window	7,500
	E-241	Van	5,450		E-355	Window	7,700
	E-242	Van	6,000		E-356	Window	8,300
	E-250	Window	5,250		E-360	Display	6,050
	E-251	Window	5,450		E-361	Display	6,200
	E-252	Window	6,000		E-362	Display	6,800
	E-260	Display	5,250		E-363	Display	7,000
	E-261	Display	5,450		E-364	Display	7,500
	E-262	Display	6,000		E-365	Display	7,700
E-300	E-340	Van	6,050		E-366	Display	8,300
	E-341	Van	6,200		E-300	Cutaway Camper	8,300

**LIGHT & MEDIUM TRUCK MODEL CODES AND GROSS VEHICLE WEIGHT**

Series	Pickups	Chassis Cab	GVW	Series	Pickups	Chassis Cab	GVW
F-100 - 4 x 2	F-100	F-170	4,600	F-250 - 4 x 2	F-252	F-272	7,500
	F-101	F-171	4,700		F-253	F-273	8,100
	F-102	F-172	4,800		F-255	F-275	7,800
	F-103	F-173	4,850	F-250 - 4 x 4	F-260	F-280	6,500
	F-104	F-174	5,000		F-261	F-281	7,100
	F-105	F-175	5,100		F-262	F-282	7,700
	F-106	F-176	5,350	F-350 - 4 x 2	F-353 F-354 F-355 F-356 F-357 F-358	F-370	6,600
	F-107	F-177	5,500			F-371	8,000
	F-108	F-178	5,400			F-372	8,300
	F-109	F-179	4,900			F-373	8,350 SR
F-100 - 4 x 4	F-110	F-180	5,250			F-374	9,000 SR
	F-111	F-181	5,300			F-375	9,000 DR
	F-112	F-182	5,600			F-376	10,000 SR
	F-113	F-183	5,700			F-377	10,000 DR
F-250 - 4 x 2	F-250	F-270	6,200			F-378	9,300
	F-251	F-271	6,900				

Series	Model Code	GVW
F-500	F-500	14,000
	F-501	16,000
	F-502	17,400
	F-503	19,200
F-600	F-600	16,000
	F-601	17,000
	F-602	19,200
	F-610	19,700
	F-611	20,200
	F-612	21,000
	F-613	22,000
	F-614	22,000
	F-615	23,000
	F-616	24,000
	F-617	22,000
	F-618	17,900
	F-600 - 4 x 4	F-650
F-660		21,700
F-661		24,000
F-6000 - Diesel	K-600	16,000
	K-601	17,000
	K-602	19,200
	K-610	19,700
	K-611	20,200
	K-612	21,000
	K-613	22,000
	K-614	22,000
	K-615	23,000
	K-616	24,000
	K-617	22,000

Series	Model Code	GVW
B-500 - Bus	B-500	14,000
	B-501	16,000
	B-502	17,400
	B-503	19,200
B-600 - Bus	B-600	16,000
	B-601	17,000
	B-602	19,200
	B-610	19,700
	B-611	20,200
	B-612	21,000
	B-613	21,000
	B-614	22,000
	B-615	22,000
	B-617	24,000
B-618	22,000	
P-350 - Parcel	P-351	6,100
	P-352	6,500
	P-353	8,000
	P-350	8,000
P-400 - Parcel	P-400	10,000
	P-401	7,400
	P-402	8,000
	P-403	7,000
P-500 - Parcel	P-500	15,000
	P-501	10,100
	P-502 (DSO)	15,000
	P-503	12,000
	P-505 (DSO)	17,000

Series	Model Code	GVW
P-600 DSO - Parcel	P-600	17,000
	P-601	15,000
	P-602	15,000
	P-603	17,000
P-5000 DSO - Parcel Diesel	G-504	12,000
	G-506	15,000

Motor Home (DSO)		
M-400	M-400	10,000
	M-402	8,000
M-500	M-502	12,000
	M-504	15,000
	M-505	12,800

Crew Cab (DSO)	
Chassis Cab	GVW
F-600	
F-700	
F-750	

**TRUCK SERIES CODE, MODEL CODE, RECOMMENDED GROSS VEHICLE WEIGHT  
HEAVY AND EXTRA HEAVY TRUCK**

SERIES	MODEL CODE	GVW (lbs.)
N-600	N-604	16,000
	N-605	19,200
	N-610	21,000
	N-611	22,000
	N-612	23,000
	N-615	24,000
	N-618	17,900
	N-619	20,200
	N-620	22,000
	N-621	22,000
	C600	C-602
C-611		22,000
C-612		23,000
C-616		20,200
C-617		21,200
N-6000	R-602	16,000
	R-603	19,200
	R-610	21,000
	R-611	22,000
	R-612	23,000
	R-613	23,000
	R-615	24,000
	R-616	20,200
	R-617	22,000
	R-618	22,000
C-6000	D-602	17,000
	D-611	22,000
	D-612	23,000
	D-615	20,200
	D-616	21,200
F-7000	K-700	19,200
	K-701	21,000
	K-702	22,000
	K-703	23,000
	K-704	24,000
	K-705	24,000
	K-706	25,500
	K-707	27,500
	K-708	22,000
	N-7000	R-700
R-702		23,000
R-703		24,000
R-704		25,500
R-707		27,500
R-709		19,200
R-710		21,000
R-711		22,000
R-712		24,000
C-7000		D-702
	D-705	27,500
	D-707	21,200
	D-708	23,000
	F-700	F-700
F-701		21,000
F-702		22,000
F-703		23,000
F-704		24,000
F-705		24,000
F-706		25,500
F-707		22,000

SERIES	MODEL CODE	GVW (lbs.)
N-700 and N-750	N-700	23,000
	N-702	23,000
	N-703	24,000
	N-704	25,500
	N-709	19,200
	N-710	21,000
	N-711	22,000
	N-712	24,000
	N-752	23,000
	N-753	24,000
	N-754	25,500
	N-760	27,500
	N-762	21,500
	N-763	22,000
	N-764	22,000
	N-765	24,000
	C-700	C-702
C-706		21,200
C-707		23,000
F-750		F-750
	F-751	22,000
	F-752	23,000
	F-753	24,000
	F-754	24,000
	F-755	25,500
	F-756	27,500
	F-757	21,500
	F-758	22,000
	C-750	C-752
C-755		27,500
C-756		23,000
L-800		F-802
	F-803	25,500
	F-804	27,500
	F-805	29,000
	F-806	31,000
	F-808	34,000
	F-809	31,000
	F-810	22,100
	F-811	31,800
	F-812	22,100
	F-813	31,800
	F-814	34,000
N-800	N-802	24,500
	N-803	25,500
	N-804	27,500
	N-805	29,000
	N-806	31,000
	N-808	34,000
	N-811	31,000
	N-812	22,100
	N-813	31,800
	N-814	22,100
	N-815	31,800
N-816	34,000	
C-800	C-802	27,500
	C-807	25,100
LT-800 and LT-880	T-800	37,000
	T-802	39,000
	T-804	43,000
	T-806	46,000
	T-807	50,000

SERIES	MODEL CODE	GVW (lbs.)
LT-800	T-811	41,000
	T-812	44,800
	T-880	39,000
	T-881	41,000
	T-882	43,000
	T-883	44,800
	T-884	46,000
	T-885	41,000
LTS-800	V-800	39,000
	V-804	46,000
	V-805	50,000
	V-809	41,000
	V-110	44,000
NT-800 and NT-880	S-800	37,000
	S-802	39,000
	S-804	43,000
	S-806	46,000
	S-807	50,000
	S-811	41,000
	S-812	44,800
	S-880	39,000
	S-881	41,000
	S-882	43,000
	S-883	44,800
S-884	46,000	
S-885	41,000	
CT-800	L-800	43,000
	L-802	39,000
	L-806	42,000
	L-807	46,000
	L-808	47,100
	L-809	49,000
L-8000	K-802	25,500
	K-803	27,500
	K-805	31,000
	K-806	32,000
	K-807	34,000
	K-808	35,000
	K-812	23,100
	K-813	31,800
N-8000	R-802	25,500
	R-803	27,500
	R-805	31,000
	R-806	32,000
	R-807	34,000
	R-808	35,000
R-810	25,100	
R-811	31,800	
C-8000	D-802	27,500
	D-806	25,100
	D-807	32,000
	D-808	35,000
LT-8000	U-800	39,000
	U-805	46,000
	U-806	50,000
	U-807	50,000
	U-808	54,000
	U-809	60,000
	U-815	41,000
	U-816	44,300
U-817	61,000	

**TRUCK SERIES CODE, MODEL CODE, RECOMMENDED GROSS VEHICLE WEIGHT  
HEAVY AND EXTRA HEAVY TRUCK**

SERIES	MODEL CODE	GVW (lbs.)	
LTS-8000	Y-800	39,000	
	Y-804	46,000	
	Y-805	50,000	
	Y-806	50,000	
	Y-807	52,000	
	Y-808	54,000	
	Y-812	60,000	
	Y-814	64,000	
	Y-818	41,000	
	NT-8000	W-800	39,000
W-805		46,000	
W-806		50,000	
W-807		50,000	
W-808		54,000	
W-812		41,000	
W-814		44,800	
CT-8000		Q-800	43,000
	Q-802	39,000	
	Q-803	45,000	
	Q-805	41,000	
	Q-807	46,000	
	Q-808	47,100	
	Q-809	48,000	
	L-900	F-900	25,500
		F-902	27,500
F-905		31,000	
F-906		32,000	
F-907		33,000	
F-908		34,000	
F-909		35,000	
F-912		23,100	
F-913		31,800	
F-914		31,000	
N-900		N-900	25,500
		N-902	27,500
		N-905	31,000
		N-906	32,000
	N-908	34,000	
	N-909	35,000	
	N-911	23,100	
	N-912	31,800	
	C-900	C-904	27,500
		C-906	31,000
C-907		32,000	
C-910		34,000	
C-912		36,000	
C-913		31,000	
C-914		25,100	
C-915		37,000	
LT-900		T-900	39,000
		T-902	41,000
	T-904	43,000	
	T-906	46,000	
	T-907	50,000	
	T-908	50,000	
	T-909	54,000	

SERIES	MODEL CODE	GVW (lbs.)
LT-900	T-911	60,000
	T-914	44,800
	T-915	48,000
	T-916	52,000
	T-917	58,000
	LTS-900	V-900
V-904		46,000
V-905		50,000
V-906		50,000
V-907		52,000
V-908		54,000
V-909		56,000
V-911		58,000
V-912		60,000
V-913		62,000
V-914		64,000
V-918		41,000
V-919		54,000
V-920		48,000
NT-900	S-900	39,000
	S-902	41,000
	S-904	43,000
	S-906	46,000
	S-907	50,000
	S-909	54,000
	S-914	44,800
	S-915	48,000
	S-916	52,000
CT-900	L-900	39,000
	L-913	42,000
	L-914	46,000
	L-915	47,100
	L-916	50,000
	L-917	51,000
	L-918	52,000
	L-919	48,000
	L-9000	K-902
K-904		35,000
K-907		28,000
K-908		31,800
N-9000	R-902	32,000
	R-904	35,000
	R-906	28,000
	R-907	31,800
W-9000	Z-903	36,000
	Z-904	29,900
	Z-905	35,000
	Z-906	36,000
	Z-907	29,640
	LT-9000	U-900
U-903		46,000
U-904		50,000
U-905		50,000
U-906		54,000
U-908		60,000
U-911		52,000

SERIES	MODEL CODE	GVW (lbs.)
LT-9000	U-914	44,800
	U-915	61,000
	U-916	48,000
	U-917	58,000
	LTS-9000	Y-900
Y-903		50,000
Y-904		50,000
Y-905		52,000
Y-906		54,000
Y-907		56,000
Y-909		58,000
Y-910		60,000
Y-911		62,000
Y-918		70,000
Y-919		48,000
NT-9000	W-903	46,000
	W-904	50,000
	W-906	54,000
	W-907	43,000
	W-911	44,800
	W-912	48,000
WT-9000	X-905	44,800
	X-906	46,000
	X-907	46,000
	X-908	47,100
	X-909	44,600
	X-915	44,800
	X-916	46,000
	X-917	46,000
	X-918	47,100
	X-919	44,600
	B-700	B-700
B-701		21,000
B-702		21,000
B-703		22,000
B-704		23,000
B-705		24,000
B-706		24,000
B-708		22,000
B-7000	J-700	20,200
	J-701	22,000
	J-702	23,000
	J-703	24,000
	J-704	24,000
	J-706	22,000
B-750	B-750	21,500
	B-751	22,000
	B-752	23,000
	B-753	24,000
	B-754	24,000
	B-755	25,500
	B-756	22,000

## REAR AXLE CODE (2780-lb. to 7400-lb. Capacity)

Code	Description	Ratio	Code	Description	Ratio	Code	Description	Ratio
A2	Ford 3300 ①	3.70	H4	Ford 3600 ①	3.15	23	Dana 61 (5300)	3.31
A3	Ford 2780 ①	4.11	03	Ford 2780	4.11	24	Dana 60 (5300)	4.10
A5	Ford 3300 ①	4.11	04	Ford 2780	4.57	25	Dana 60 (5300)	4.56
B4	Dana 60 ① (5300)	4.10	05	Ford 3300	4.11	27	Dana 70 (7400)	4.10
B8	Ford 2780 ①	3.50	08	Ford 3300	3.50	28	Dana 70 (7400)	4.56
B9	Ford 3300 ①	3.50	09	Ford 3300	3.70	71	Dana 60 (5050)	3.54
C7	Dana 60 ① (5300)	3.54	10	Ford 3050	3.25	72	Dana 60 (5050)	3.73
C8	Dana 60 ① (5300)	3.73	11	Ford 3050	3.50	73	Dana 60 (5050)	4.10
D6	Dana 70 ① (7400)	3.73	12	Ford 3050	3.70	36	Dana 70 (7400)	3.73
D7	Dana 70 ① (7400)	4.10	02	Ford 3300	3.00	37	Dana 60 (5300)	3.54
H1	Ford 3600 ①	3.00	17	Ford 3300	3.25	38	Dana 60 (5300)	3.73
H2	Ford 3600 ①	3.50	18	Ford 2780	3.50	G1	Dana 60 ① (5050)	3.54
H3	Ford 3600 ①	4.11	22	Dana 70 (7400)	4.88	G3	Dana 60 ① (5050)	4.10

① Limited-Slip or Traction-Lok

## REAR AXLE CODE (11,000-lb to 18,500-lb. Capacity)

Code	Description	Capacity	Ratio	Code	Description	Capacity	Ratio	Code	Description	Capacity	Ratio
E1	Eaton 16244	(17,500)	5.57/7.75	HH	Eaton 17221	(18,500)	7.17/9.77	53	Rockwell H-170	(17,500)	6.14
E2	Eaton 16244	(17,500)	6.17/8.58	FQ	Eaton 17121	(18,500)	6.14	54	Rockwell H-170	(17,500)	6.83
E3	Eaton 16244	(17,500)	6.50/9.04	GQ	Eaton 17121	(18,500)	6.50	55	Rockwell H-170	(17,500)	7.17
F1	Eaton 15201	(15,000)	5.14/7.17	HQ	Eaton 17121	(18,500)	7.17	62	Rockwell F-106	(15,000)	6.20
F2	Eaton 15201	(15,000)	5.83/8.12	JQ	Eaton 17121	(18,500)	7.60	64	Rockwell F-106	(15,000)	6.80
F3	Eaton 15201	(15,000)	6.33/8.81	41	Rockwell D-100	(13,000)	5.83	66	Rockwell F-106	(15,000)	7.20
EH	Eaton 17221	(18,500)	5.57/7.60	42	Rockwell D-100	(13,000)	6.20				
FH	Eaton 17221	(18,500)	6.14/8.38	44	Rockwell D-100	(13,000)	6.80				
GH	Eaton 17221	(18,500)	6.50/8.87	52	Rockwell H-170	(17,500)	5.86				

## REAR AXLE CODE (22,000-lb and 23,000-lb. Single-Axle)

Code	Description	Capacity	Ratio	Code	Description	Capacity	Ratio	Code	Description	Capacity	Ratio
DB	Eaton 18221	(22,000)	5.57/7.60	HG	Eaton 19121	(23,000)	4.56	H3	Rockwell R-171	(23,000)	4.63
EB	Eaton 18221	(22,000)	6.14/8.38	DK	Eaton 18121	(22,000)	6.50	H4	Rockwell R-171	(23,000)	4.88
FB	Eaton 18221	(22,000)	6.50/8.87	EK	Eaton 18121	(22,000)	7.17	H5	Rockwell R-171	(23,000)	5.29
GB	Eaton 18221	(22,000)	7.17/9.77	AP	Eaton 19221	(23,000)	4.33/5.90	H6	Rockwell R-171	(23,000)	5.86
AG	Eaton 19121	(23,000)	4.11	CP	Eaton 19221	(23,000)	5.43/7.39	H7	Rockwell R-171	(23,000)	6.14
BG	Eaton 19121	(23,000)	4.33	DP	Eaton 19221	(23,000)	6.17/8.40	H9	Rockwell R-171	(23,000)	5.70
CG	Eaton 19121	(23,000)	4.88	EP	Eaton 19221	(23,000)	6.67/9.08	1A	Rockwell R-170	(23,000)	4.11
DG	Eaton 19121	(23,000)	5.43	GP	Eaton 19221	(23,000)	4.11/5.60	2A	Rockwell R-170	(23,000)	4.33
EG	Eaton 19121	(23,000)	6.17	H1	Rockwell R-171	(23,000)	4.11	3A	Rockwell R-170	(23,000)	5.29
FG	Eaton 19121	(23,000)	6.67	H2	Rockwell R-171	(23,000)	4.33	4A	Rockwell R-170	(23,000)	5.14

## TANDEM REAR AXLE CODES

Code	Description	Capacity	Ratio	Code	Description	Capacity	Ratio	Code	Description	Capacity	Ratio
EC	Eaton 30DSC	(32,000)	6.50	LF	Eaton 34DSC	(34,000)	3.70	FW	Eaton 34DTE	(34,000)	6.14/8.38
FC	Eaton 30DSC	(32,000)	7.17	FF	Eaton 34DSC	(34,000)	5.57	GW	Eaton 34DTE	(34,000)	6.50/8.87
GC	Eaton 30DSC	(32,000)	7.60	GF	Eaton 34DSE	(34,000)	6.14	HW	Eaton 34DET	(34,000)	7.17/9.77
JF	Eaton 34DSC	(34,000)	4.11	HF	Eaton 34DSE	(34,000)	6.50				
BF	Eaton 34DSC	(34,000)	4.33	MF	Eaton 34DSE	(34,000)	7.17				
CF	Eaton 34DSC	(34,000)	4.56	KF	Eaton 34DSE	(34,000)	7.60				
DF	Eaton 34DSC	(34,000)	4.88								

TRANSMISSION CODES

Code	Description	Code	Description
Bronco		Light, Medium and Heavy Truck, Parcel Delivery and School Bus (Cont'd)	
C	3 Speed Manual	Ø	Fuller T-905B Direct 5 Speed
Econoline—Club Wagon		P	Warner T-19 4 Speed
C	3 Speed Manual Ford	P	Fuller RT 613 Direct 13 Speed
G	Automatic	P	C-6 Automatic
Light, Medium and Heavy Truck, Parcel Delivery and School Bus		Q	Spicer 5652 Direct 5 Speed
A	New Process 435/4 Speed	R	Spicer P8716-3A Overdrive 16 Speed
B	Spicer P8516-3B Overdrive-16 Speed	S	Spicer 5756-B Direct 5 Speed
C	Ford-Manual-3 Speed	T	New Process 542 FO Overdrive 5 Speed
C	Fuller RT-610 Direct 10 Speed	T	Fuller RTO-9509 B-9 Speed Overdrive
D	Clark 387 V Direct 5 Speed	U	Spicer 6852G Direct 5 Speed
E	Warner T-19 (Parcel)-4 Speed	V	Fuller RT-910 Direct 10 Speed
E	Fuller 5 H74 Direct 5 Speed	W	Spicer 6352B Direct 5 Speed
F	Fuller 5HA74 (Aluminum) Direct 5 Speed	X	Fuller T-905A Direct 5 Speed
F	Warner T-18-4 Speed	Y	Transmatic MT41-6 Speed
G	Automatic	Z	Transmatic MT40-6 Speed
G	Spicer SST 6 + 1 7 Speed	1	Spicer 8552A Direct 5 Speed
G	Warner T-87G (Parcel)-3 Speed	1	Transmatic MT 42-6 Speed
H	Allison MT650	2	Clark 282V Direct 5 Speed
J	Fuller RTO 9513 Overdrive-13 Speed	3	Fuller RT-906 Direct 6 Speed
J	FMX Automatic (Parcel)	4	Clark 280 VO Overdrive 5 Speed
J	Spicer 6453 Direct 5 Speed	5	Fuller RTO-910 Overdrive 10 Speed
L	Allison AT540	6	Fuller RTO-915 Overdrive 15 Speed
M	Clark 285V Direct 5 Speed	7	Clark 385V Direct 5 Speed
N	Spicer 6352 Direct 5 Speed	8	Allison MT640
Ø	New Process 542FL Direct 5 Speed	9	Fuller RT-915 Direct 15 Speed
		9	New Process 542 FD Direct 5 Speed



<h1 style="margin: 0;">Wheels and Tires</h1>	<p><b>GROUP</b></p> <h1 style="margin: 0;">11</h1>
--	--

<p><b>PART 11-01</b></p> <p>General Wheel and Tire Service ..... <b>11-01-01</b></p> <p><b>PART 11-02</b></p> <p>Wheels and Tires—</p> <p>Drop Center Rim ..... <b>11-02-01</b></p> <p><b>PART 11-03</b></p> <p>Wheels and Tires—</p> <p>Two-Piece Rims ..... <b>11-03-01</b></p> <p><b>PART 11-04</b></p> <p>Wheels and Tires—</p> <p>Three-Piece Rims ..... <b>11-04-01</b></p>	<p><b>PART 11-10</b></p> <p>Wheel Hubs and Bearings—</p> <p>Front (Except Front Drive) ..... <b>11-10-01</b></p> <p><b>PART 11-11</b></p> <p>Wheel Hubs and</p> <p>Bearings—Rear ..... <b>11-11-01</b></p> <p><b>PART 11-12</b></p> <p>Wheel Hubs and Bearings—</p> <p>Front Wheel Drive ..... <b>11-12-01</b></p> <p><b>PART 11-14</b></p> <p>Wheel Hubs and Bearings—</p> <p>Rear (Full Floating Axle) ..... <b>11-14-01</b></p>
---	--

## PART 11-01 General Wheel and Tire Service

Applies to All Models			
COMPONENT INDEX	Page	COMPONENT INDEX	Page
FRONT WHEEL BEARINGS		TIRES INSPECTION .....	01-03
Maintenance .....	01-03	WHEELS	
Cleaning and Inspection .....	01-03	Balancing .....	01-03
		Cleaning and Inspection .....	01-03

### SAFETY

#### SAFETY PRECAUTIONS WHEN SERVICING TRUCK TIRES

CAUTION AND SAFETY FIRST are bywords when handling tires, particularly truck tires. Careful attention to the suggestions that follow may prevent crippling injuries, or even death. **Make it a rule to respect the terrific force contained in an inflated tire.** You may be glad some day that you did.

Prepare for any tire repair operation in a safe and efficient way. In changing tires on drop center wheels, remove the wheel and tire from the truck, as changing tires with the wheel on the

**truck is hazardous, more difficult, and takes more time.** In servicing of all tires use caution not to drop them (or the wheels or assemblies) on the feet, hands or body, or heavily on the floor (Fig. 1). Practice good methods of lifting; use your legs as well as your arms and your body. This will help to prevent painful, internal injury. When carrying tires or wheels don't step in oil or grease. **Keep the floor clean and dry.**

Deflating a tire properly is very important to your safety. First, reduce the pressure as much as you possibly can by pushing the valve core plunger. **Only then should you remove the valve core.**

Keep your eyes away from the valve: Fig. 2 shows the safe way to do it.

Demounting tires from wheels or rims requires special care. Tires on drop center rims are best handled on a wheel holder, or tire-changing machine (Fig. 3).

This will prevent cuts on hands and wrists and will make it unnecessary to use a mallet for seating the tire.

Use only standard tire mounting tools and equipment. The use of makeshift tools, screwdrivers or pliers to force tires on or off rims or wheels is dangerous.

Always lubricate tire beads to assure sealing of tire beads on rim.

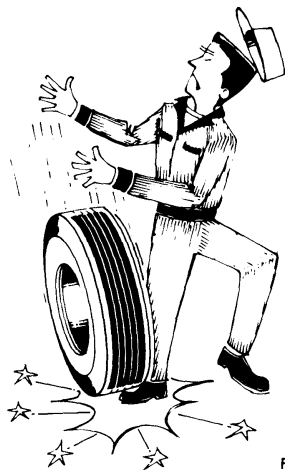

F1857-A

FIG. 1 Handling Wheels and Tires

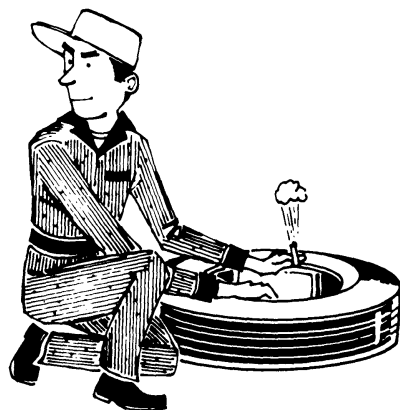

F1853-A

FIG. 2 Safe Air Removal



F1858-A

FIG. 4 Use of Tire Irons

A careful inspection should be made of the tire and all necessary repairs should be performed. A tire spreader is very helpful (Fig. 5) but use care when working around it. Keep the spreader arms closed when the machine is idle.

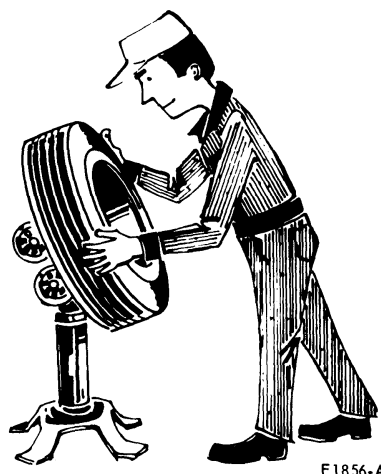

F1856-A

FIG. 3 Changing Tire on Drop Center Rim

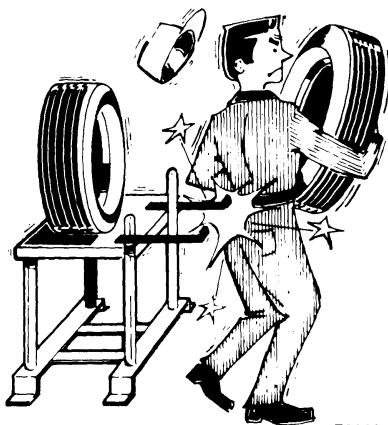

F1860-A

FIG. 5 Tire Spreader

A new Rotunda tire changer is available. Details include a bead seater/inflator using an automatically adjustable inflation ring, which aids in properly seating the bead for inflation. To properly operate the new Rotunda tire changer, follow the instructions provided.

As with the drop-center rims, be certain on split-rim assemblies that all air is out before unlocking a rim or ring. **Use special care when using tire irons.** Grip them firmly and keep them free of oil and grease. They can slip and fly with tremendous force (Fig. 4).

Inspect the rim parts carefully for rust, damage or distortion (Fig. 6). Never use rims, locking rings or flanges which are out of shape, rusted or cracked or broken in any way. **Never use a ring or other rim parts of different manufacture than the original rims or any different size, or type.**

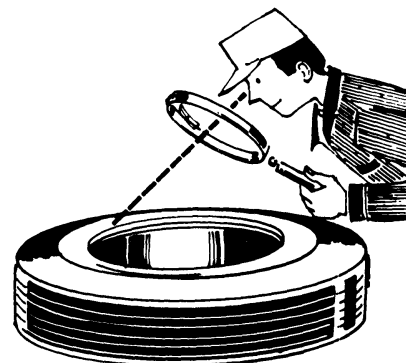

F1854-A

FIG. 6 Visual Inspection

Tires and rims often require a buffing operation before being mounted once the regular repairs have been made.

**Always wear Safety Goggles, or a face shield when performing any buffing operation.**

Avoid hammering rings or rims with steel hammers. Small bits of steel may be broken off the hammer or rim, flying into the eyes (wear safety goggles) face or body. Use rubber-covered, steel-headed hammers wherever possible (Fig. 7). Rubber mallets only should be used on passenger car tires; although with modern tire changing equipment no pounding is necessary.

Make certain the rim ring is seated to full depth of the groove, fits tightly all around, and is securely locked.

Stand away from the valve stem as far as possible while inflating tires. Avoid a position where the face or body is immediately over the work being done on any tire in which there is pressure.

With certain types of wheels, however, it is necessary to seat the rings while the tire is being inflated. In either case **before inflating study the next step.**

Attach a portable safety device, made especially for the purpose, to the assembly. This portable device should be used with all types of wheels and rims.

If the assembly is not of the type which requires inflation to seat the rings,



F1859-A

FIG. 7 Seating of Rings

a **Safety Cage** should be used, although the portable device is the best (Fig. 8).

Use only accurate, tested gauges to insure proper air pressure. Check all gauges regularly with a master gauge.

Play it **SAFE**. Set a good example for others who work with you. Follow the above suggestions completely. **If you are ever tempted to take a short cut because you are in a hurry, that is the time that you could get hurt.**



F1855-A

FIG. 8 Inflation Details

## ADJUSTMENTS

### WHEEL BALANCING

See the instructions provided with the Rotunda Wheel Balancer.

Make certain that the brakes are not dragging and wheel bearings are properly adjusted before attempting to spin the wheels. On vehicles equipped with disc brakes, push the brake shoes into the caliper to free the rotor.

### FRONT WHEEL BEARING MAINTENANCE

Wheel bearings are adjustable to correct for bearing and spindle shoulder wear. Satisfactory operation and long life of bearings depend on proper adjustment and correct lubrication. **If bearings are adjusted too tightly, they will overheat and wear rapidly. An adjustment that is excessively loose will cause pounding and contribute to uneven tire wear, steering difficulties and inefficient brakes. The bearing adjustment should be checked at regular inspection intervals.**

## CLEANING AND INSPECTION

### WHEELS

Wheel stud nuts should be inspected and tightened twice within the first 500 miles of operation. After the first 1000 miles of operation, they should again be inspected and tightened. Loose wheel stud nuts may cause shimmy and vibration. Elongated stud holes in the wheels may also result from the loose stud nuts.

**Keep the wheels and hubs clean. Stones or lumps of mud wedged between the wheel and drum will unbalance a wheel and tire.**

**Check for damage that would affect the runout of the wheels. Wobble or shimmy caused by a damaged wheel will eventually damage the wheel bearings and cause uneven tire wear. Inspect the wheel rims for dents that could permit air to leak from the tires.**

### TIRES

The tires should be checked frequently to be sure that the air pressures agree with those specified for

the tires and vehicle model. Inspect the tire threads, and remove all stones, nails, glass or other objects that may be wedged in the thread. Check for holes or cuts that may permit air leakage from the tire, and make the necessary repairs.

Inspect the tire side walls for cuts, bruises, and other damage. If internal damage is suspected, demount the tire from the wheel for further inspection, repair or replacement.

Check the tire valve for air leaks, and replace the valve if necessary. Replace any missing valve caps.

On F-100, -250, -350, Econoline and Bronco models, it is important that all wheels be balanced. Fig. 9 describes common tire wear conditions.

### FRONT WHEEL BEARINGS

Wheel bearings are adjustable, to correct for bearing and shoulder wear of the spindle. Satisfactory operation and long life of bearings depend on proper adjustment and correct lubrication. If

**bearings are adjusted too tightly, they will overheat and wear rapidly. An adjustment that is excessively loose will cause pounding and contribute to uneven tire wear, steering difficulties and inefficient brakes. The bearing adjustment should be checked at regular inspection intervals.**

Front hub assemblies and bearings should be cleaned, inspected and lubricated whenever the hub assemblies are removed or at the mileage/time periods indicated in the maintenance schedule.

New hub assembly grease seals should be installed when the hub is removed. A damaged or worn seal may permit bearing lubricant to reach the brake linings, resulting in faulty brake operation and necessitating premature replacement of linings.

Bearing adjustment is described in Part 11-10 for front wheels. Part 11-12 covers front drive bearing adjustment. Parts 11-11 and 11-14 cover rear wheel bearing adjustments.

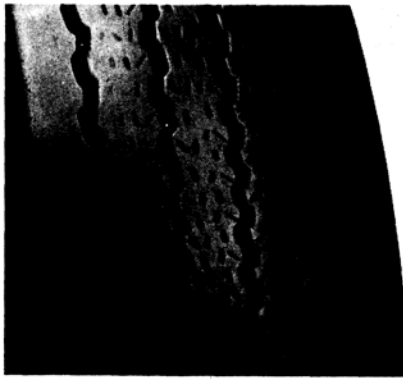

UNDERINFLATION

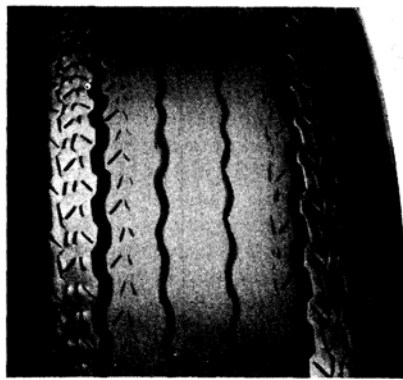

OVERINFLATION



CUPPING—UNDERINFLATION AND/OR MECHANICAL IRREGULARITIES

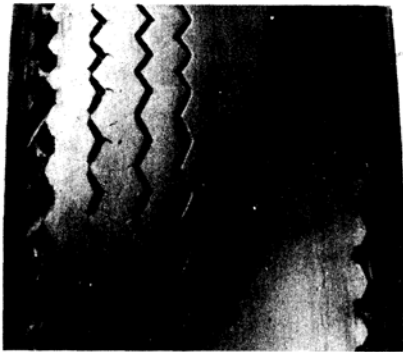

INCORRECT TOE-IN OR EXTREME CAMBER

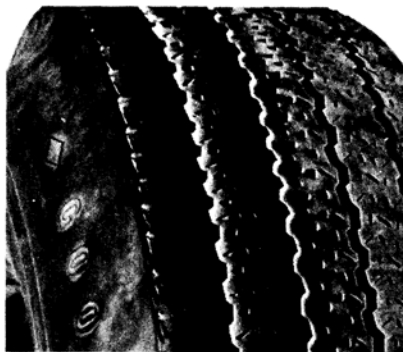

FEATHERING DUE TO MISALIGNMENT OR SEVERE CORNERING

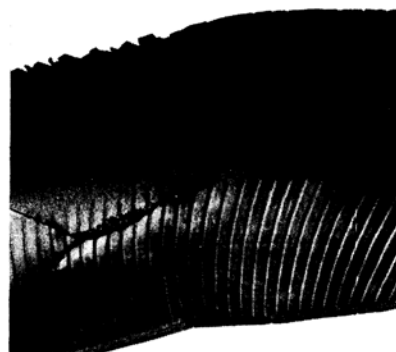

STONE BRUISE



STONE BRUISE



UNDERINFLATION

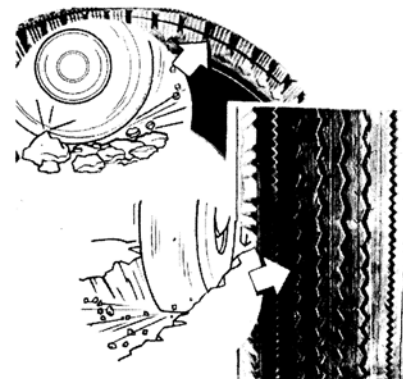

ROCK CUT

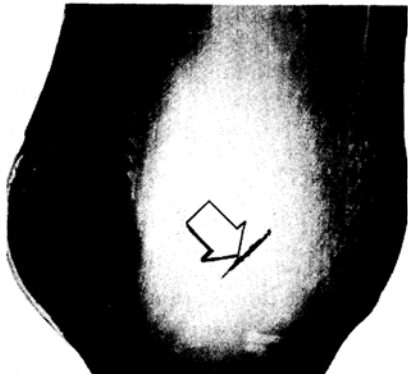

BRUISE

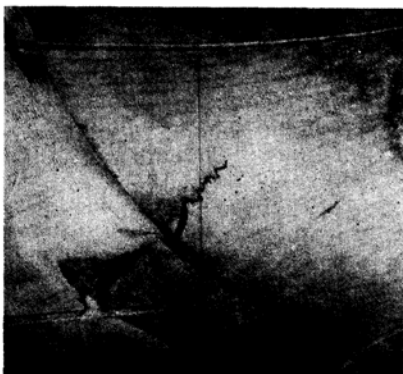

HEAT BRUISE

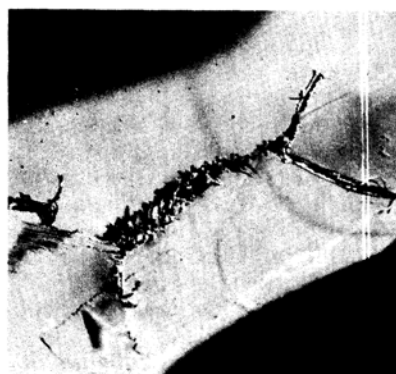

DOUBLE BRUISE—SHARP OBJECT AND RESULTING FATIGUE

FIG. 9 Tire Wear Conditions

F1467-D

# PART 11-02 Wheels and Tires Drop Center Rim

Applies to Bronco, Econoline Light and Medium Trucks			
COMPONENT INDEX	Page	COMPONENT INDEX	Page
FRONT WHEEL ASSEMBLY		REAR WHEEL ASSEMBLY	
Description .....	02-01	Description .....	02-01
FRONT WHEEL ASSEMBLY		WHEEL REPLACEMENT .....	02-02
4-WHEEL DRIVE		SPECIFICATIONS .....	02-03
Description .....	02-01	TIRE REPLACEMENT .....	02-02

## DESCRIPTION

### FRONT WHEEL ASSEMBLY

Each front wheel and tire assembly is bolted to its respective front hub and brake drum or rotor assembly. Two opposed tapered roller bearings are installed in each hub (Figs. 1 and 2). A grease retainer is installed at the inner end of the hub to prevent lubricant from leaking into the drum. The entire assembly is retained on its spindle by the lock nut and/or adjusting nut and cotter pin.

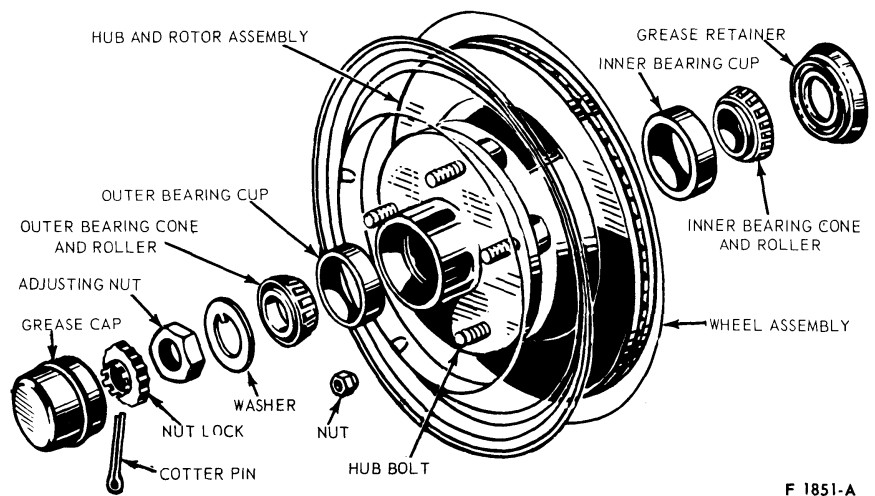

FIG. 2 Front Hub, Bearings and Grease Retainer—Disc Brakes—F100-F350

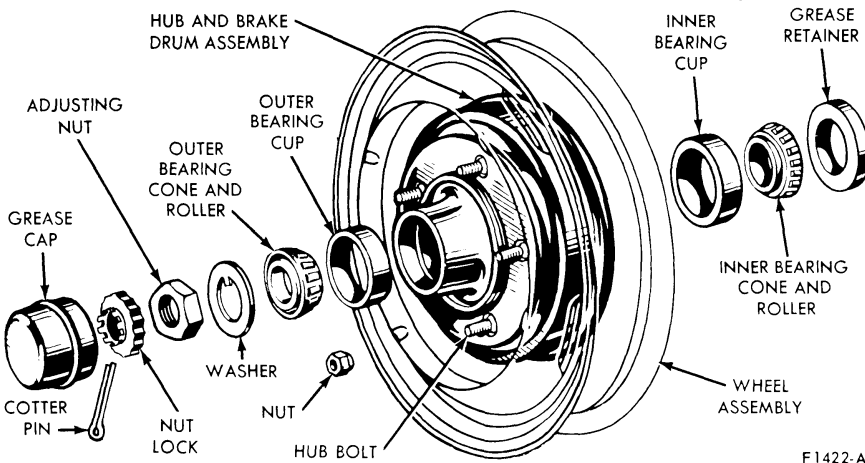

FIG. 1 Front Hub, Bearings and Grease Retainer—Drum Brakes—Econoline

### FRONT WHEEL ASSEMBLY—FOUR-WHEEL DRIVE

The front axles used on 4-wheel drive models are described in Parts 15-30, 15-32 and 15-33 of this manual. The locking hub assemblies are described in Part 11-12.

### REAR WHEEL ASSEMBLY

Information on rear wheels may be found in Group 11, Parts 11 and 14.

## REMOVAL AND INSTALLATION

### WHEEL REPLACEMENT

#### Light Vehicles

##### Removal

1. Pry off the hub cap or wheel cover (if the vehicle is so equipped), and loosen but do not remove the wheel stud nuts.
2. Raise the vehicle until the wheel and tire clear the floor. When installing the hub cap, notice the wheel hubs. The hub cap should be positioned on the wheel over one of the retaining nubs and the two locating nubs. Be sure that the lip of the hub cap is firmly seated in the groove of the retaining nub, and then force the cap over the second retaining nub. **Any other procedure necessitates heavy pounding with possible damage to the hub cap.**
3. Remove the wheel stud nuts and the wheel and tire from the hub and drum assembly, or the hub and rotor assembly.

##### Installation

1. Clean all dirt from either the hub and drum or hub and rotor assembly. The replacement wheel and tire must be clean.
2. Position the wheel and tire on the hub and drum assembly or the hub and rotor assembly, and install the wheel stud nuts. Tighten the stud nuts enough to hold the wheel firmly in place. **Always tighten alternate nuts to draw the wheel evenly against the hub and drum (or hub and rotor).**

On dual wheels, except E-300, F-350, P-350 and P-400 be sure to back off the outer nut before tightening the inner nut. Then tighten the outer nut. E-300, F-350, P-350 and P-400 dual wheels have mounting bolt holes

which are alternately flared inward and outward. These surfaces must be mated when the wheels are mounted. Fig. 3 illustrates the dual wheel radial alignment locating pin used on certain applications.

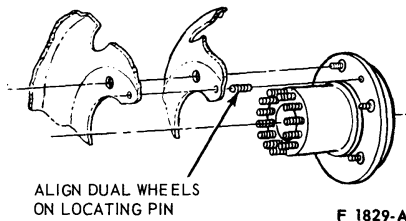

FIG. 3 Dual Wheel Radial Alignment to Hub (E-300, F-350)

3. Lower the vehicle to the floor, and tighten the wheel stud nuts to the specified torque. **On a new vehicle, and each time a wheel and tire is installed, the wheel nuts should be torqued to specification and rechecked at 500 miles.**

##### Removal

1. Loosen but do not remove the wheel stud nuts.
2. Raise the vehicle until the wheel and tire clear the floor.
3. Remove the wheel stud nuts and the wheel and tire from the hub and drum.

#### Medium Vehicles

##### Installation

1. Clean all dirt from the hub and drum. The replacement wheel and tire must be clean.

2. Position the wheel and tire on the hub and drum, and install the wheel stud nuts. Tighten the stud nuts enough to hold the wheel firmly in place. **Always tighten alternate nuts to draw the wheel evenly against the hub and drum.**

**On dual wheels, be sure to back off the outer nut before tightening the inner nut. Then tighten the outer nut.**

3. Lower vehicle to the floor, and tighten the wheel stud nuts to the specified torque. **On a new vehicle, and each time a wheel and tire is installed, the wheel nuts should be checked for tightness.**

### TIRE REPLACEMENT PRECAUTIONS

The tire must be completely deflated before removal, and the bead must not be damaged by a tire iron.

After installation, a tube tire should be inflated to recommended pressure, deflated, and then inflated again to insure that the tube is not folded inside the tire. Be sure the tube flap is properly positioned before inflating the tire. **On F-100, -250, -350, Econoline, and Bronco series, it is important that each front and rear tire and wheel be balanced.**

On F-100, -250, -350, Econoline and Bronco, all wheels should be balanced. On vehicles with dual rear wheels, only front wheels should be balanced.

**When installing tires on light trucks, thoroughly lubricate the tire beads. Inflate the tire until the bead seats against the rim of the wheel, then deflate to the specified pressure. Follow the instructions supplied with the Rotunda (KKRE-888 or equivalent) tire changer.**

**SPECIFICATIONS****WHEEL TORQUE LIMITS – F-100 THRU F-350, ECONOLINE, BRONCO, P-350 THRU -500**

Model	Nut Size	Ft-Lb
E-100, E-200 F-100 (4 x 4), U-100 (Std. Wheel) P-100 F-250-250 (4 x 4) P-350 (W-5200 lb. Axle)	1/2-20	90
F-350, P-350 P-400, (W/8-Stud Wheel and 7400 lb. Axle)	9/16-18	135
E-300 (8-Stud Wheel) with Single Rear Wheels	1/2-20	135
E-300 (8-Stud Wheel) with Dual Rear Wheels	9/16-18	210

Model	Nut Size	Ft-Lb
F-350, P-350, P-450 (W/Dual Wheels) and 7400 lb Axle)	9/16-18	210
P-350, P-400 (W/17" Wheels)	5/8-18	210
P-500	3/4-16 or 1-1/8-16	450

CF 1804C

# PART 11-03 Wheels and Tires— Two-Piece Rims

Applies to All 500-9000 Series Vehicles			
COMPONENT INDEX	Page	COMPONENT INDEX	Page
TIRE REMOVAL AND MOUNTING — Two-Piece Rims .....	03-01	TIRE REMOVAL AND MOUNTING — Two-Piece Semi-Drop Center Rims .....	03-02

## DESCRIPTION

Two-piece rims are used on disc and cast wheels with tube-type tires only.

Refer to Part 11-01 for safety procedures and illustrations.

## REMOVAL AND INSTALLATION

The tire must be completely deflated before removal, and the bead must not be damaged by a tire iron.

After installation, a tube tire should be inflated to recommended pressure, deflated, and then inflated again to insure that the tube is not folded inside the tire. Be sure the tube flap is properly positioned before inflating the tire.

It is recommended that tire-changing equipment be used in changing all truck tires. See Safety Precautions in Part 11-01.

### TIRE REMOVAL AND MOUNTING—TWO-PIECE RIM

#### Removing Tire from Wheel

If no tire-changing machine is available, remove tire as detailed in following Steps.

1. First, remove valve core and completely deflate the tire. Then, place the wheel (ring side up) on the floor. Insert the hook end of the rim tool between the ring flange and the tire and press downward on bead. Continuing around the ring, pry the tire off the tapered seat of the ring (Fig. 1).
2. To remove the ring, insert the straight end of the rim tool into the notch, and force ring opposite the notch down with foot, and pry off. Be careful not to bend side ring.
3. Force upper tire bead into well opposite the valve slot and with tire

4. Stand assembly in vertical position. Lubricate second bead. At top of assembly insert straight end of tool between bead and back flange of rim

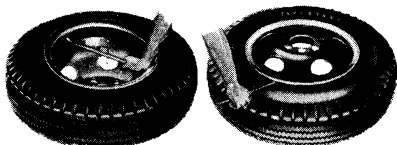

F1460-B

FIG. 1 Removing Rim and Removing Tire—Two-Piece Rim

at about a 45 degree angle. Turn tool so that it is perpendicular to rim. Pry second bead off.

5. Turn tire over. With rim tools, loosen bead on opposite bead seat. This can be further aided by using foot pressure.

Make sure one portion of second bead is still in the rim well, then pry opposite portion of bead over edge of rim. This will free the tire from the rim.

#### Mounting Tire to Wheel

1. Place tire on rim so that valve is in line with rim slot and insert valve through the slot (Fig. 2). Force first bead down into well of rim just to side of valve. Mount first bead over rim lip

with rim tool, progressing around the tire.

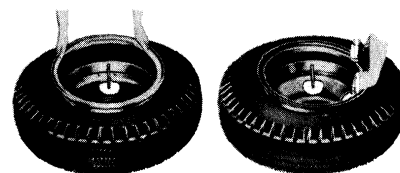

F1027-B

FIG. 2 Positioning and Starting Ring—Two-Piece Rim

2. To apply second bead, start at point opposite valve and press tire bead over rim lip and into rim well (Fig. 3). Mount remainder of bead over rim lip by means of thin tire tool, being careful not to pinch tube. If necessary, insert second tire tool and lubricate last 6 inches of bead before completing mounting.

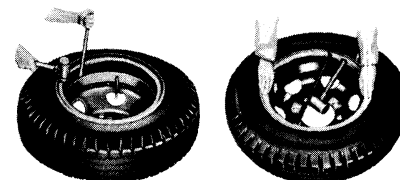

F1028-B

FIG. 3 Installing and Checking Ring—Two-Piece Rim

3. Place half of side ring under the rim



lip with cutaway portions in position as shown. Insert thin end of rim tool or heavy screwdriver and pull ring outward toward centered position. Strike with mallet to start ring over rim lip, then strike remaining portion to force it over rim lip.

### TIRE REMOVAL AND MOUNTING—TWO-PIECE SEMI-DROP CENTER RIM WITH C-STYLE RING

Recent developments make possible the removal and mounting of tires from this type of wheel-rim combination with mechanical tire-changing equipment. If available, follow instructions of equipment manufacturer. Otherwise, use the following instructions.

This two-piece wheel uses a split C-type ring, as shown in Fig. 4.

#### Removal of Side Ring from Rim with Tire

1. Deflate tire completely and place the wheel (ring side up) on the floor.
2. Break the tire bead free from the rim, being careful not to damage the bead (Fig. 5).
3. Insert the straight end of the rim tool into and under the notch in the ring (Fig. 6).
4. Force the tool downward to disengage the ring from the rim gutter. Work the tool around the rim, freeing the ring from the rim, and remove the ring.

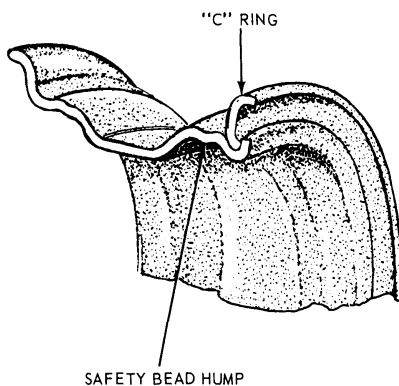
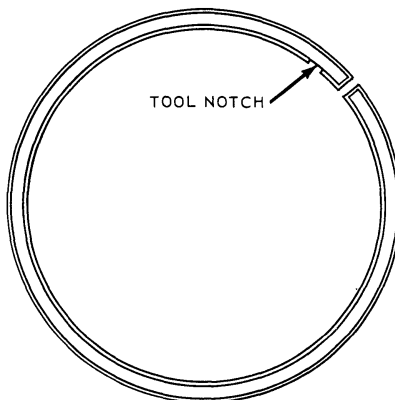

FIG. 4 Two-Piece Split Ring—Light Truck

5. Turn the wheel over and loosen the opposite tire bead from the rim by driving the hook end of the rim tool between the rim flange and the tire bead. Pry the tire bead away from the taper, and remove the tire from the rim (Fig. 7).

#### Mounting Tire to Wheel

1. Position the tube in the tire and place the wheel (gutter side up) on the floor. Soap both beads of the tire and position the tire on the rim. It is important that the tire be soaped well as it must be forced over the safety bead hump and the rim edge (Fig. 8).
2. Position the ring with the notch about 3 inches from the valve stem.
3. Insert the rim tool under the ring at a position approximately 180 degrees from the notch and pry tire onto rim. Work the remaining section of rim over the gutter with a second tool.
4. Make certain that the ring is entirely seated in the gutter. If the ring is not seated correctly as described, it may be forced off violently, either during inflation or when the vehicle is operated.
5. After installation, over-inflate the tire to 75 psi to snap the tire beads over the bead humps and fully seat the tire against the rim and side ring. Deflate the tire, then reinflate it to recommended pressure to insure that the tube is not folded inside the tire. Be sure the tube flap is properly positioned before inflating the tire. Always use a cage or safety chain during initial inflation.



F1473 - B

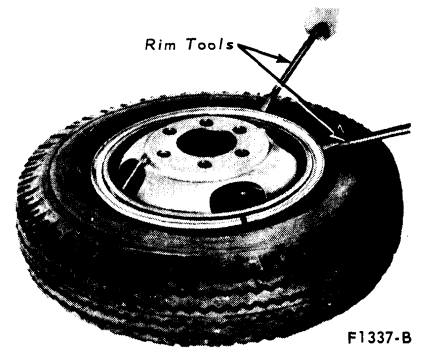

F1337-B

FIG. 5 Loosening Tire Bead



F1338-B

FIG. 6 Removing Split Ring

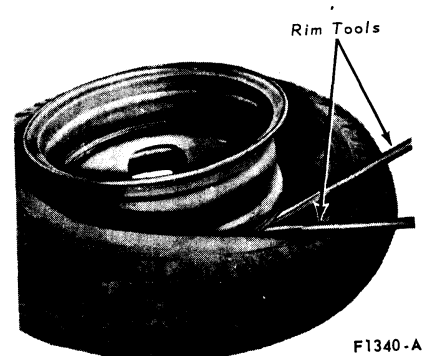

F1340-A

FIG. 7 Removing Tire From Rim

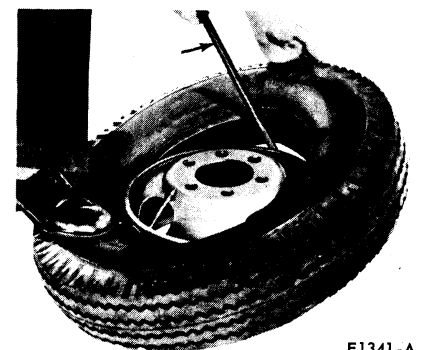

F1341-A

FIG. 8 Installing First Tire Bead on Wheel

# PART 11-04 Wheels and Tires— Three-Piece Rims

Applies to All 500-9000 Series Vehicles

COMPONENT INDEX	Page	COMPONENT INDEX	Page
TIRE REMOVAL AND MOUNTING —		TIRE REMOVAL AND MOUNTING —	
Three-Piece Rims .....	04-01	Cast Spoke Wheels .....	04-02

## DESCRIPTION

Three-piece rims are used on disc and cast wheels. Fig. 1 shows a dual wheel sectional view.

Demountable rims for cast-spoke wheels are secured by a ramp at the back edge of each spoke, together with a lug retained by a stud and nut at the edge of each spoke. Refer to Part 11-01 for safety procedures and illustrations.

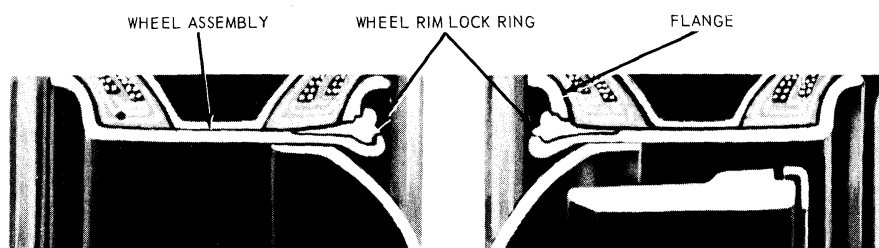

3-PIECE RIM, DUAL WHEELS

FIG. 1 Three-Piece Rim—Dual Wheel Sectional View

F1806-A

## REMOVAL AND INSTALLATION

The tire must be completely deflated before removal, and the bead must not be damaged by a tire iron.

After installation, a tube tire should be inflated to recommended pressure, deflated, and then inflated again to insure that the tube is not folded inside the tire. Be sure the tube flap is properly positioned before inflating the tire.

### TIRE REMOVAL AND MOUNTING—THREE-PIECE RIM

Tire mounting procedures are the same for disc wheels and for cast wheels equipped with the three-piece rims. However, cast wheels require special final centering and runout adjustment.

#### Removing Tire from Wheel

1. Place the wheel and deflated tire on the floor, with the ring up.
2. Insert the straight end of the rim tool in the locking ring depression and loosen the tire bead by pressing down on the side ring (Fig. 2).
3. Insert the straight end of the rim tool in the notch provided in the locking ring, and pry the locking ring out of the gutter (Fig. 2).



F1461-A

FIG. 2 Loosening Tire Bead and Locking Ring—Three-Ring Rim

4. Lift out the locking ring, and remove the slide ring (Fig. 3).



F1462-A

FIG. 3 Removing Locking Ring and Positioning Locking Ring—Three-Piece Rim

5. Turn the wheel over and loosen the tire bead from the rim by driving the hooked end of the rim tool between the rim flange and the tire bead.
6. Pry the tire bead away from the taper all around the rim until tire is free and remove the tire.

#### Mounting Tire to Wheel

1. Position the wheel (gutter side up) on the floor. Soap both beads of the tire and position the tire on the rim.
2. Position the solid side ring on the tire and insert the tapered toe of the split locking ring between the rim and the side ring (Fig. 3).
3. Using a soft hammer, drive the locking ring into place (Fig. 4). Start at one end of the split ring and progressively drive the ring into the gutter until the entire ring is seated (Fig. 4).

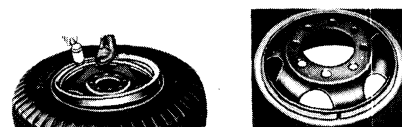

F1463-A

FIG. 4 Starting Locking Ring and Locking Ring Installed—Three-Piece Rim

The ring must be entirely seated around the entire circumference of the rim. The split ends must be engaged in the gutter, or the ring will be forced off

violently during inflation or when vehicle is driven. When inflating the tire do not stand in front of the ring. See Safety Precautions in Part 11-01.

### TIRE REMOVAL AND MOUNTING—CAST WHEELS

#### Removal

1. To remove the rim and tire from a cast wheel, apply the parking brake, and block at least one wheel. Raise the vehicle and remove the rim clamps.
2. With dual rear wheels, lift off the outer rim and tire, remove the spacer rim, and the inside rim and tire assembly.

#### Installation

1. To install the tire and rim on a dual wheel, place the inner tire and wheel

on the wheel hub. The rim must ride high enough up on the tapered retainer flange of the inner section of the wheel to prevent the assembly from sliding down on the tapered surface.

2. Position the spacer between the inner and outer rim.
3. Place the outer rim and tire assembly on the wheel, and install the clamps (Fig. 5).
4. Tighten the top clamp until the spacer pushes the inner rim onto the tapered surface of the wheel inner section.
5. Tighten the bottom clamp to help center the rim on the wheel.
6. Tighten the remaining clamps alternately and evenly, and torque all wheel nuts to specification. Lateral or side runout should not exceed 1/8-

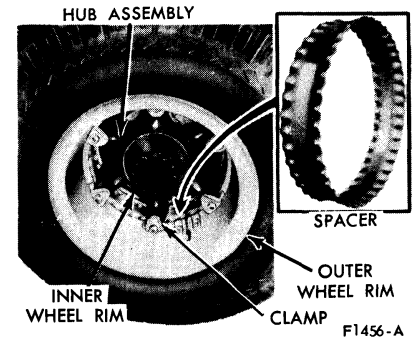

FIG. 5 Three-Piece Rim Installed on Cast Wheel  
inch for the front rims and 1/4-inch for the dual rear rims. **Lateral or side runout must be checked at the outer bead surface of the wheel.**

# PART 11-10 Wheels, Hubs and Bearings— Front (Except Front Drive)

Applies to All Models			
COMPONENT INDEX	Page	COMPONENT INDEX	Page
FRONT WHEEL ASSEMBLY		FRONT WHEEL GREASE	
Description .....	10-01	SEAL AND BEARING	
FRONT WHEEL BEARING		Removal and Installation .....	10-05
Adjustment .....	10-04	Repacking .....	10-05

## DESCRIPTION

### FRONT WHEEL ASSEMBLY

Each front wheel and tire assembly is bolted to its respective front hub and brake drum or rotor assembly. Two opposed tapered roller bearings are installed in each hub (Fig. 1 and 2, Part 11-02, and Fig. 3 and 4 of this Part). A grease retainer is installed at the inner end of the hub to prevent lubricant from leaking into the drum or onto the rotor. The entire assembly is retained to its spindle by the locknut and/or adjusting nut and cotter pin, or an adjusting nut and lock nut combination (Figs. 3 and 4).

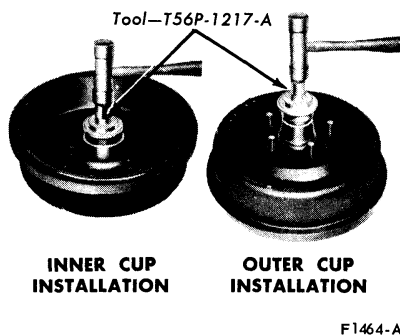

FIG. 1 Installing Bearing Cups

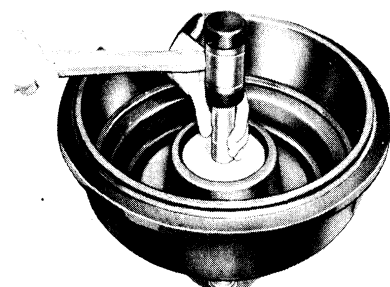

FIG. 2 Installing Grease Retainer

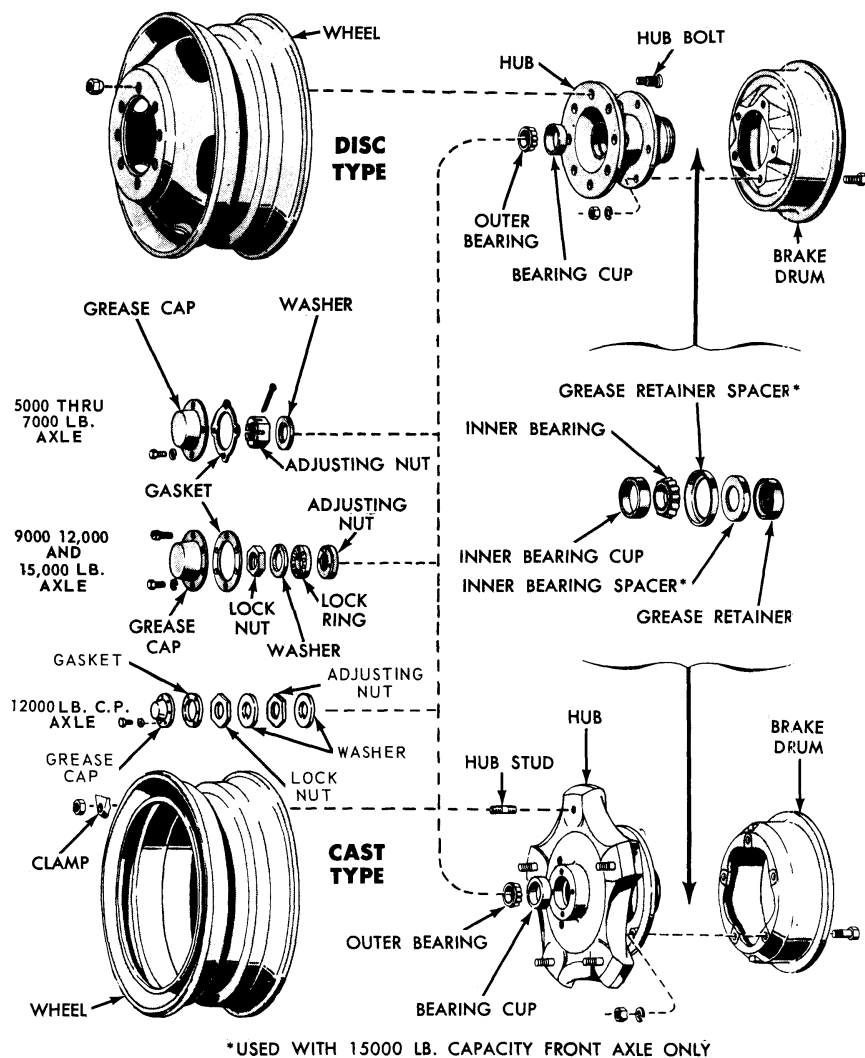

FIG. 3 Typical Front Hubs and Bearings

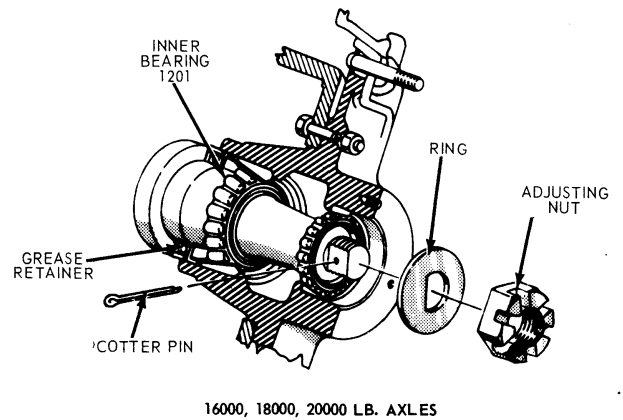
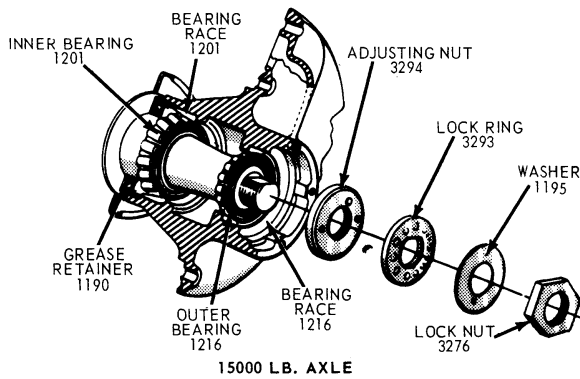
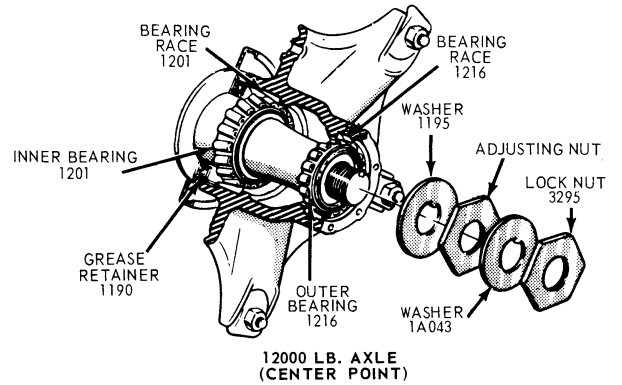
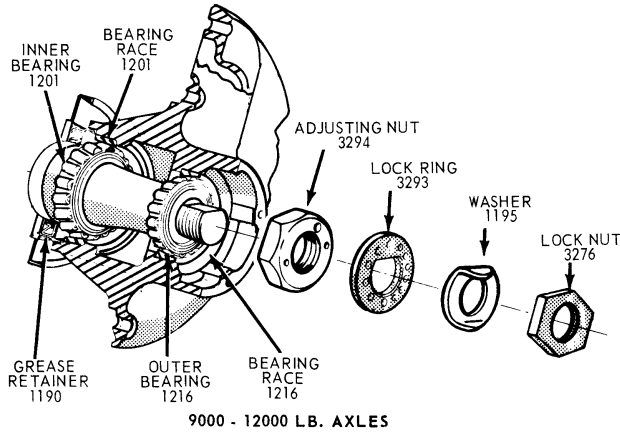
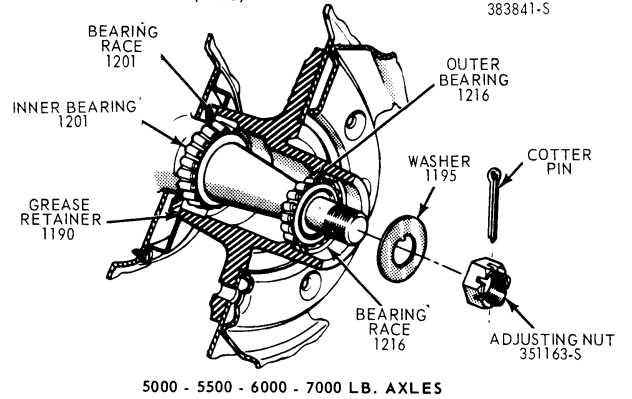
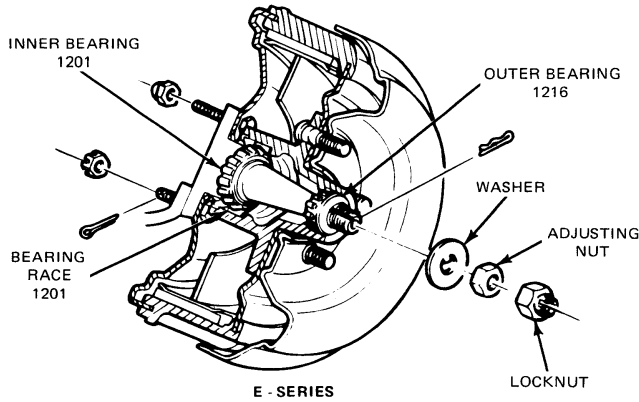
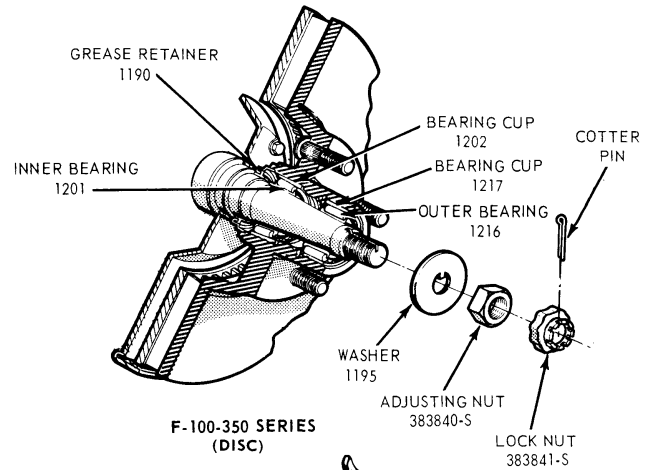
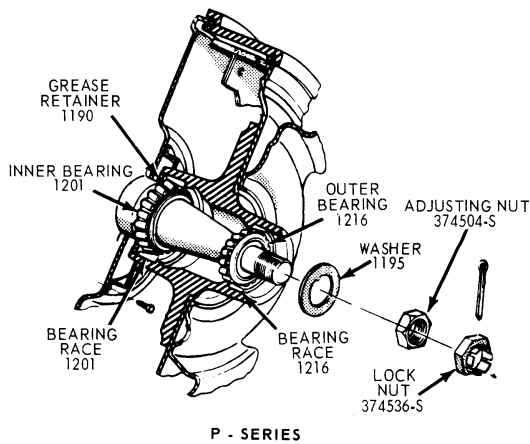

FIG. 4 Front Hubs, Bearings and Grease Retainers

## ADJUSTMENTS

### FRONT WHEEL BEARING ADJUSTMENT

To check the wheel bearing adjustment, raise the front of the vehicle. Then, grasp the tire at the sides, and alternately push inward and pull outward on the tire. If any looseness is felt, adjust the front wheel bearings.

#### F-100, -250, -350, (4x2) AND ECONOLINE

1. Remove the hub cap or wheel cover and remove the grease cap from the hub.
2. Wipe any excess grease from the end of the spindle and remove the cotter pin and nut lock.
3. While rotating the wheel, torque the adjusting nut (Fig. 1, Part 11-02) to 17-25 ft-lb to seat the bearings.
4. Install the nut lock so a slot is aligned with the cotter pin hole in the spindle.
5. Back off the adjusting nut and nut lock two slots of the nut lock and install the cotter pin.
6. Check the front wheel rotation. If the wheel rotates freely with no noticeable end play, install the grease cap. If the wheel is still loose or if it rotates roughly or noisily, the bearing cones, rollers, and cups are dirty or worn and should be cleaned or replaced.
7. Install the hub cap.

#### P-350 THRU-500

1. Remove hub cap, if so equipped, and remove grease cap from hub.
2. Remove any excess grease from the end of the spindle and remove the adjusting nut cotter pin.
3. While rotating the wheel, torque the adjusting nut (See Fig. 4, under Disassembly and Assembly), 40 to 55 ft-lb to seat the bearings.
4. If necessary, back off the adjusting nut to the next slot so nut aligns with the cotter pin hole. Then, back off the adjusting nut two slots and install the cotter pin.
5. Check the front wheel rotation. If the wheel rotates freely with no noticeable end play, install the grease cap. If the wheel is still loose, or if it rotates roughly or noisily, the bearing cones, rollers and cups are dirty or worn and should be cleaned or replaced.
6. Install the hub cap, if so equipped.

### ALL MEDIUM, HEAVY AND EXTRA-HEAVY TRUCKS

#### Single Nut with Cotter Pin (5000-7000 Pound Front Axles)

1. While rotating the wheel, torque the adjusting nut, 70 to 100 ft-lb, to seat the bearings.
2. Back off the adjusting nut 180 degrees (one half turn).
3. Hand tighten the adjusting nut finger tight (13 to 17 in-lb) while moving the top part of the tire in and out.
4. If the cotter pin hole lines up with a slot in the nut, insert and secure a new cotter pin. If it does not, back off the adjusting nut to align a slot with the first available cotter pin hole. Final bearing adjustment must provide .001 to .010-inch end play.
5. Install the gasket and grease cap and adjust the brakes. **The final adjustment must not result in a preloaded bearing.**

#### Double Nut with Lock Ring (15000-Pound Front Axle)

1. While rotating the wheel in both directions, torque the adjusting nut, 100 to 125 ft-lb to seat the bearings.
2. Back off the adjusting nut one complete turn (See Fig. 4, under Removal and Installation).
3. Again, rotate the wheel in both directions, and retorque the adjusting nut, 40 to 55 ft-lb.
4. Back off the adjusting nut to obtain an initial .004 to .010-inch end play between the wheel hub and spindle.
5. Install the lock ring. Make sure that adjacent nut dowel is inserted into a lock ring hole.
6. Install the washer with the dimple indexed in one of the holes in the lock ring.
7. Install lock nut and torque, 100 to 125 ft-lb.
8. Recheck the end play. (Final bearing adjustment must allow .001 to .010 end play.) Re-adjust if necessary.
9. Bend the washer outward in two places, on opposite sides of lock nut, to lock the nut in position.
10. Install the gasket and grease cap and adjust the brakes. **The final adjustment must not result in a preloaded bearing.**

#### Double Nut with Double Washer (12000-Pound Center Point Axle)

1. While rotating the wheel in both directions, torque the adjusting nut, 100 to 125 ft-lb to seat the bearings.
2. Back off the adjusting nut one complete turn (see Fig. 4, under Disassembly and Assembly).
3. Again, while rotating the wheel in both directions, retorque the adjusting nut, 40 to 55 ft-lb.
4. Back off the adjusting nut to obtain an initial .004 to .010-inch end play between the hub and spindle.
5. Install the outer washer and lock nut and torque, 100 to 125 ft-lb.
6. Recheck the end play (final limit .001 to .010 inch). Re-adjust if necessary.
7. Bend the washer outward in two places, on opposite sides of lock nut, to lock the outer nut in position.
8. Install the gasket and grease cap and adjust the brakes. **The final adjustment must not result in a preloaded bearing.**

#### Single Nut with Cotter Pin (16000-, 18000-and 20000-Pound Front Axle)

1. While rotating the wheel in both directions, torque the adjusting nut, 100 to 125 ft-lb to seat the bearings.
2. Back off the adjusting nut one complete turn (see Fig. 4, under Disassembly and Assembly).
3. Again rotate the wheel in both directions, and retorque the adjusting nut, 40 to 55 ft-lb.
4. If necessary, back off the adjusting nut to align a slot with the next cotter pin hole.
5. Using the same cotter pin hole as a reference point, back off the adjusting nut to the next slot to allow the wheel to rotate freely within the limits of .001 to .010-inch end play.
6. Insert and secure the cotter pin.
7. Install the gasket and grease cap and adjust the brakes. **The final adjustment must not result in a preloaded bearing.**

#### Double Nut with Lock Ring (9000-and 12000-Pound Front Axle)

1. While rotating the wheel in both directions, torque the adjusting nut,

- 100 to 125 ft-lb to seat the bearing.
2. Back off the adjusting nut one complete turn.
3. Then, again rotate the wheel in both directions, and retorque the adjusting nut, 40 to 55 ft-lb.
4. Back off the adjusting nut to obtain an initial .004 to .010-inch end play between the hub and spindle.
5. Install the lock ring making sure the adjusting nut dowel is inserted into the lock ring.
6. Install the outer washer, locating dimple in washer in one of the lock ring holes, and install the lock nut. Torque, 100 to 150 ft-lb.
7. Recheck to make sure the final bearing adjustment allows .001 to .010-inch end play. Re-adjust if necessary.
8. Bend the washer outward in two places, on opposite sides of the lock nut, to lock the outer nut in position.
9. Install the gasket and grease cap and adjust the brakes. **The final adjustment must not result in a preloaded bearing.**

## DISASSEMBLY AND ASSEMBLY

### FRONT WHEEL GREASE SEAL AND BEARING REMOVAL AND INSTALLATION AND/OR REPACKING

Wheel bearing lubricant is a lithium-base grease, ESA-M1C75B.

Sodium-base grease is not compatible with lithium-base grease and should not be intermixed. Therefore, do not lubricate front and/or rear wheel bearings without first ascertaining the type of original wheel bearing lubricant. Usage of incompatible bearing lubricants could result in premature lubricant breakdown.

If bearing adjustment will not eliminate looseness or rough and noisy operation, the hub and bearings should be cleaned, inspected, and repacked with specified wheel grease. If the bearing cups or the cone and roller assemblies are worn or damaged, they should be replaced.

#### E-100,-300,P-350,-400 AND -500

1. Raise the vehicle until the wheel and tire clear the floor. Remove wheel and tire from hub. If drums will not remove easily, back off the brake shoe adjusting screw so that the shoes do not contact the brake drum. Remove grease cap from the hub.
2. Remove the cotter pin, nut lock, adjusting nut and washer from the spindle (Fig. 1, Part 11-02).
3. Remove the outer bearing cone and roller. Pull the hub and drum assembly off the wheel spindle. Then, remove and discard the grease retainer. Remove the inner bearing cone and roller from the hub. **Remove all traces of old lubricant from bearings, hubs, and axle spindle.**
4. Inspect the cups for scratches, pits or cracks. If the cups are worn or damaged, remove them with a drift.
5. Clean the inner and outer bearing cones and rollers with solvent and dry thoroughly. **Do not spin the bearings dry with compressed air.**
6. Inspect the cones and rollers for cracks, nicks, brinelling, or seized rollers. Inspect the grease retainer

and replace it if it is cracked, nicked, or dented.

7. Cover the spindle with a clean cloth and brush all loose dust and dirt from the brake assembly. **Remove the cloth from the spindle carefully to prevent dirt from falling on the spindle.**
8. Install the inner and outer bearing cups in the hub with the appropriate installing tool (Fig. 1). Be sure to seat the cups properly in the hub. The cups will be properly seated when they are fully bottomed.
9. Pack the inside of the hub with C1AZ-19590-B Multi-Purpose Lubricant. Fill the hub until the grease is flush with the inside diameters of both bearing cups. Pack the bearing cones and rollers with wheel bearing grease. Use a bearing packer for this operation. If a packer is not available, work as much lubricant as possible between the rollers and cages. Lubricate the cone surfaces with grease.
10. Place the inner bearing cone and roller in the inner cup and install the grease retainer (Fig. 2) with the appropriate driving tool. Be sure that the retainer is fully bottomed.
11. Install the hub and drum on the wheel spindle. **Keep the hub centered on the spindle to prevent damage to the grease retainer or the spindle threads.**
12. Install the outer bearing cone and roller and the flat washer on the spindle, then install the adjusting nut, and adjust the wheel bearing as outlined under Adjustments. Install the adjusting nut lock, cotter pin and grease cap.

#### F100-F350 DISC BRAKE EQUIPPED

The removal and installation of front wheel grease seals and bearings for disc brake equipped vehicles differs only in two respects from the procedure for drum brake equipped vehicles.

First, it is necessary to remove the brake caliper (refer to Part 12-24). In this case, the caliper can be suspended by wiring it above the hub and rotor. **Be careful not to twist or strain the flexible brake line.**

Then follow the procedure outlined for E-100 and E-300 and P-350 and P-500 with only one exception: a different Tool, T37T-1190-B is required to install the special shielded grease seal.

Finally, install the brake caliper following the steps given in Part 12-24.

#### MEDIUM, HEAVY AND EXTRA-HEAVY VEHICLES

There are two basic types of hub, disc and cast, shown in Fig. 3. The basic design of the hub bearings is the same in all hubs, but minor differences in size exist between the various models. The outer bearing attaching parts differ according to front axle weight capacity as indicated in Fig. 3. For further detailed views of hubs, bearings, and grease retainers, see Fig. 4.

1. Raise the vehicle until the tires clear the floor and install safety stands to support the front axle. Remove the grease cap and gasket from the hub.
2. To check the wheel bearing adjustment, alternately push inward and outward on the tire. If there is any excessive looseness, or if there is no end play, adjust the front wheel bearing.
3. With 5000, 5500, 6000, 7000, 16000, 18000 or 20000-pound capacity front axles, remove the cotter pin, adjusting nut and flat washer from the spindle. Proceed to Step 4.

With 9000, 12000 or 15000-pound capacity front axles, remove the lock nut, washer, locking ring and the adjusting nut and pin. Proceed to Step 4.

With a 12000-pound capacity center point front axle, remove the lock nut, inner washer, adjusting nut and outer washer.

4. Inspect the condition of the spindle and nut threads to insure a free running nut when reassembling.
5. Remove the outer bearing cone and roller. Pull the hub and drum assembly off the spindle.
6. Remove the inner bearing and seal using a brass drift. **Be careful not to damage the bearing cage.**

7. Remove all traces of old lubricant from the bearings, hubs and axle spindle. Inspect the cups for pitting, galling or unusual wear. If either cup is worn or damaged, remove it with a brass drift.
8. Clean the inner and outer bearing cones and rollers with solvent and dry them thoroughly. **Do not spin the bearings dry with compressed air.**
9. Inspect the cones and rollers for pitting, galling or unusual wear. Closely inspect the rollers for end wear and flat or rough spots. Replace all worn or damaged assemblies. It is recommended that the cone and roller assemblies and cups be replaced in sets.
10. Replace the grease retainer.
11. Cover the spindle with a clean cloth and brush all loose dust and dirt from the brake assembly. Remove the cloth from the spindle carefully to prevent dirt falling on the spindle.
12. Install the inner and outer bearing cups in the hub with the appropriate tool (Fig. 1). Check for proper seating of the new bearing cups by trying to insert a 0.0015-inch feeler gauge between the cup and wheel hub. The feeler gauge should not enter.
13. Pack the inside of the hub with lithium-base wheel bearing grease (C1AZ-19590-B). Fill the hub until the grease is flush with the inside diameters of both bearing cups.  
Pack the bearing cones and rollers with wheel bearing grease. Use a bearing packer for this operation. If a packer is not available, work as much lubricant as possible between the rollers and cages. Lubricate the cone surfaces with grease.
14. Place the inner bearing cone and roller in the inner cup and install the grease retainer with the appropriate tool. Be sure the retainer is fully bottomed.  
On all synthetic-type seals, coat the seal lips with wheel bearing grease (C1AZ-19590-B) before installing the hub and drum. On seals not coated on the OD with sealer by the supplier, coat the grease seal bore in the hub with a thin coat of non-hardening sealer prior to installing the grease seal.
15. Install the hub and drum on the wheel spindle. **Keep the hub centered on the spindle to prevent damage to the grease retainer or the spindle threads.**
16. With 5000, 5500, 6000, 7000, 16000, 18000 or 20000-pound capacity front axles, install the outer bearing cone and roller and the flat washer on the spindle. Then, install the adjusting nut.

With 9000, 12000 and 15000-pound capacity front axles, install the outer bearing cone and roller and the bearing adjusting nut.

With a 12000-pound capacity center point front axle, install the washer and adjusting nut. Make the final bearing adjustment. See Adjustments, this Part.

### MEDIUM, HEAVY AND EXTRA HEAVY VEHICLES (OIL LUBRICATION)

Stemco Seals and National Seals, available as regular production options, provide sealing where oil is used for bearing lubrication. The tools required for Stemco Seal Installation are only available from the Stemco warehouse.

Refer to Specifications for the tooling required. Fig. 5 illustrates a front wheel Stemco Seal Installation.

### FRONT HUB SEAL INSTALLATION Stemco Seals

Clean all parts thoroughly before starting the installation.

1. Oil the spindle and push the axle ring flush against the axle face where applicable.
2. Remove all burrs from the wheel hub bore seal area, and clean again.
3. Pack grease between the spring and the seal lip. This will prevent the spring from dislocating when the seal is installed.
4. Position the seal in the hub bore (Part Number Up). Drive the seal into

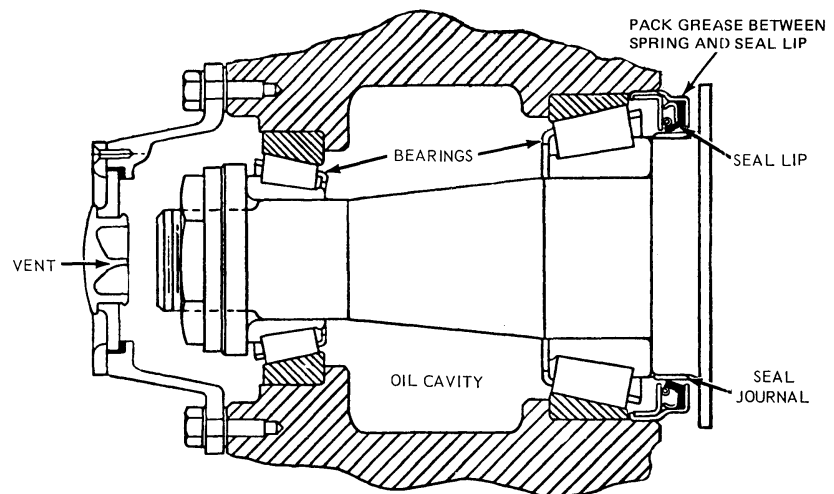

VIEW FOR 15000 LB. FRONT AXLE ONLY

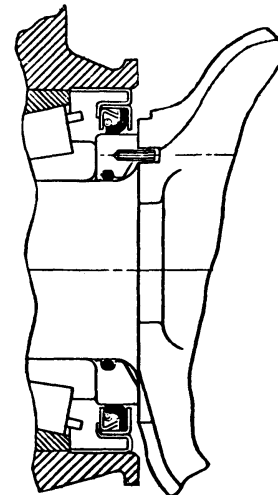

FIG. 5 Front Seal Installation (Stemco)



position using the correct tool. It must be perfectly square with the bore, and bottom evenly.

5. Install the wheel and adjust the bearings. Install the Stemco hub cap.
6. Remove the filler plug and add oil (ESW-M2C105-BSAE 90). Double check the oil level before releasing the vehicle for service. Oil level must be between the oil level line on the hub cap and 1/4-inch above the line.

### NATIONAL SEALS

Install (Fig. 6) as follows:

1. Clean all parts, remove rough spots and install axle ring flush against face where applicable.
2. Position the seal into the hub (notice oil side marking) with drive tool and lightly hammer into a press fit.
3. Install the wheel and adjust the bearings the same as for any seal installation. Install the see-through hubcap and the retaining screws.
4. Remove the filler plug and add oil to level on see-through hubcap.

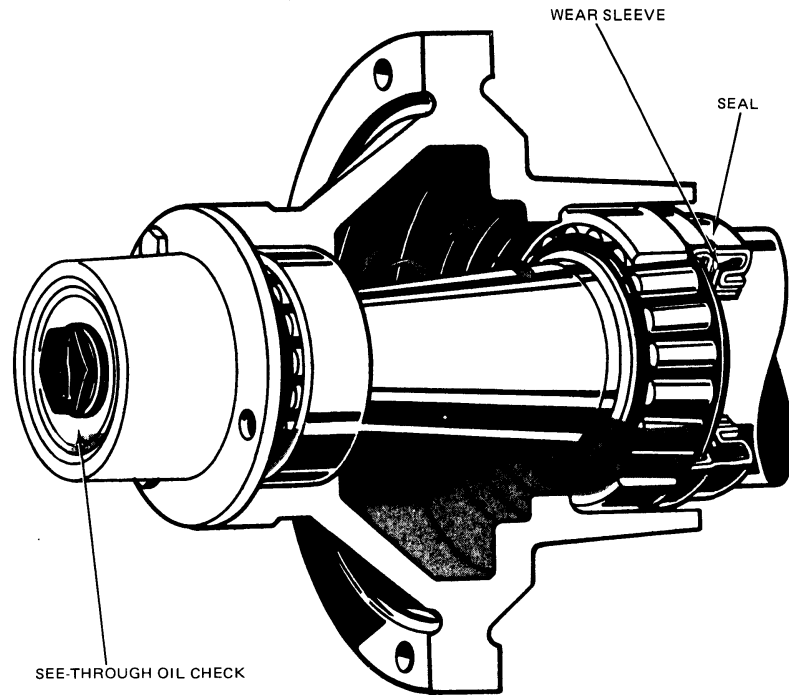

F1831-A

FIG. 6 National Seal Installation

## SPECIFICATIONS

### WHEEL TORQUE LIMITS—F-100 THRU F-350, ECONOLINE, BRONCO, P-SERIES

Model	Nut Size	Ft-Lb
E-100, E-200		90
F-100 (4 x 4), U-100 (Std. Wheel) F-250-250 (4 x 4) P-350-3500 (W-5200-lb. Axle)	1/2-20	90
E-300 (Std. Wheel) (W/Single Rear Wheels)	1/2-20	135
F-350, P-350	9/16-18	135
F-350, P-350, P-450 (W/Dual Wheels and 7400-lb. Axle)	9/16-18	210
P-350, P-400 (W/17" Wheels)	5/8-18	210
E-300 (W/Dual Rear Wheels)	9/16-18	210

### WHEEL TORQUE LIMITS—500 THRU 9000 SERIES

Description	Nut Size	Ft-Lb
Disc Wheel Nut	All	450
Cast Wheel Rim Nut	3/4-10	170-220

### SPECIAL SERVICE TOOLS

Tool No.	Description
T-59T-1197-B	Front Wheel Bearing Adjustment Spanner Wrench
Tool 1175-AB	Grease Seal Remover Head
T50T-100-A	Impact Slide Hammer
T56P-1217-A	Front Hub Bearing Cup Replacer
T73T-1190-B	Shielded Grease Seal Installer

### SPECIAL SERVICE TOOLS—STEMCO

Ford Seal Kit Part No.	Stemco Tool No.	Ford Seal Kit Part Name
DOHZ-1190-A	5064-5351	Kit - Front Hub Grease Retainer and Wiper
	5061-5062	
DOHZ-1190-B	5066-5353	
DOHZ-1190-C	5067-5398	
DOHC-1190-D	None-5386	
DOHZ-1190-E	5007-5358	

Kits on this page consist of one axle ring and one seal for just one wheel.

CF1810-C

# PART 11-11 Wheel Hubs and Bearings—Rear

Applies to Bronco, Econoline E100, E200 and F-100 Only			
COMPONENT INDEX	Page	COMPONENT INDEX	Page
AXLE SHAFT		REAR WHEEL BEARING	
Removal and Installation .....	11-01	AND SEAL	
DESCRIPTION .....	11-01	Removal and Installation.....	11-01

## DESCRIPTION

### REAR WHEEL ASSEMBLY

The rear wheel brake drum assembly is attached to studs on the rear axle shaft flange by three retainers. The wheel (and tire) is mounted on the same rear axle shaft flange studs, and is held against the hub and drum by the wheel nuts. The rear wheel bearing is pressed onto the axle shaft just inside the shaft flange. The assembly is retained to the rear axle housing by the bearing retainer plate, which is bolted to the housing flange.

## REMOVAL AND INSTALLATION

### REMOVAL OF AXLE SHAFT

Synthetic wheel bearing seals are used. The entire length of the shaft (including spline), up to the seal journal, must pass through the seal without contact. **Roughening or cutting of the seal during axle removal or installation will result in early seal failure.** The rear axle shafts, wheel bearings and oil seals can be replaced without removing the differential assembly from the axle housing.

1. Remove the wheel cover or hub cap, wheel and tire from the brake drum.
2. Remove the retainers that secure the brake drum to the axle shaft flange, and remove the drum from the flange.
3. Working through the hole provided in each axle shaft flange, remove the nuts that secure the wheel bearing retainer plate.
4. Pull the axle shaft assembly out of the axle housing (Fig. 1). **The brake backing plate must not be dislodged.** Install one nut to hold the plate in place after the axle shaft is removed.

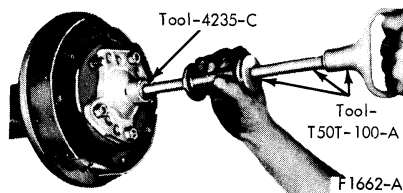

FIG. 1 Removing Axle Shaft

### REAR WHEEL BEARING AND SEAL

#### Removal

Synthetic seals must not be cleaned, soaked or washed in cleaning solvents.

**Removal of the wheel bearings from the axle shaft makes them unfit for further use.**

1. Loosen the inner retainer ring by nicking it deeply with a cold chisel in several places (Fig. 2). It will then slide off easily.
2. Remove the bearing from the axle shaft with Tool T60K-1225-A.
3. Whenever a rear axle shaft is replaced, the oil seal must be

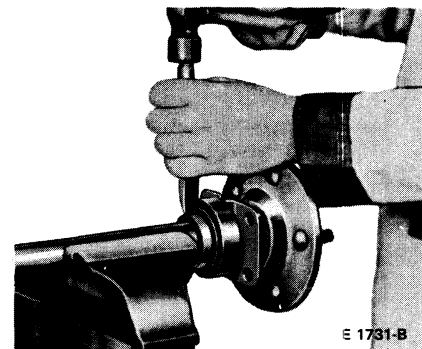

FIG. 2 Removing Rear Wheel Bearing Retainer Ring

replaced. Remove the seal with Tool 1175-AB and a slide hammer.

### REAR WHEEL BEARING AND SEAL

#### Installation

1. Inspect the machined surface of the axle shaft and the axle housing for rough or other irregularities which would affect the sealing action of the

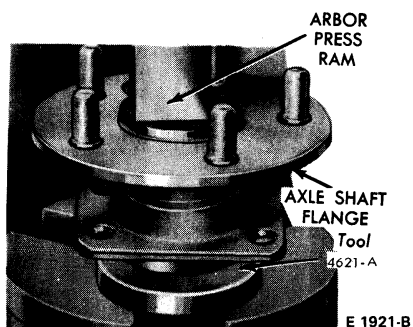

FIG. 3 Installing Rear Wheel Bearing

oil seal. Check the axle shaft splines for burrs, wear or twist. Carefully remove any burrs or rough spots. Replace worn or damaged parts.

2. Lightly coat wheel bearing bores with axle lubricant.
3. Place the bearing retainer plate on the axle shaft, and press the new wheel bearing on the shaft with Tool 4621-A

(Fig. 3). Do not attempt to press on both the bearing and the inner retainer ring at the same time.

4. Using the bearing installation tool (Tool 4621-A), press the bearing inner retainer ring on the shaft until the retainer seats firmly against the bearing.
5. Install the new oil seal with the tools shown in Fig. 4. Wipe a small amount of oil resistant sealer on the outer edge of the seal before it is installed. Do not put sealer on the sealing lip.

#### INSTALLATION OF AXLE SHAFT

1. Carefully slide the axle shaft into the housing so that the rough forging of the shaft will not damage the oil seal. Start the axle splines into the side gear, and push the shaft in until the bearing bottoms in the housing.
2. Install the bearing retainer plate and

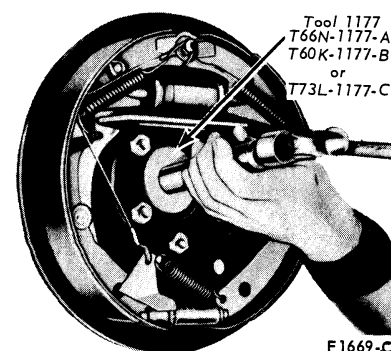

FIG. 4 Installing Rear Wheel Bearing Oil Seal

the nuts that secure it. Torque the nuts to specification.

3. Install the brake drum and the drum attaching (Tinnerman) nuts.
4. Install the wheel and tire on the drum. Install the wheel cover.

# PART 11-12 Wheel Hubs and Bearings— Front Wheel Drive

Applies to Bronco, F-100, F-250 and F-600 Only			
COMPONENT INDEX	Page	COMPONENT INDEX	Page
ADJUSTMENTS .....	12-01	DISASSEMBLY AND ASSEMBLY.....	12-06
DESCRIPTION .....	12-01	REMOVAL AND INSTALLATION .....	12-02

## DESCRIPTION

Front drive assemblies are available for Bronco, F-100, F-250 and F-600 vehicles.

## ADJUSTMENTS

### FRONT WHEEL BEARING ADJUSTMENT

If equipped with free-running hubs, refer to Removal and Installation—Free-Running Hub, in this Part. (Standard on Bronco, optional on F-100.)

### BRONCO AND F-100

1. Raise the vehicle and install safety stands.
2. Back off the brake adjusting screw if necessary.
3. Remove the front hub grease cap and the driving hub snap ring (Fig. 1).

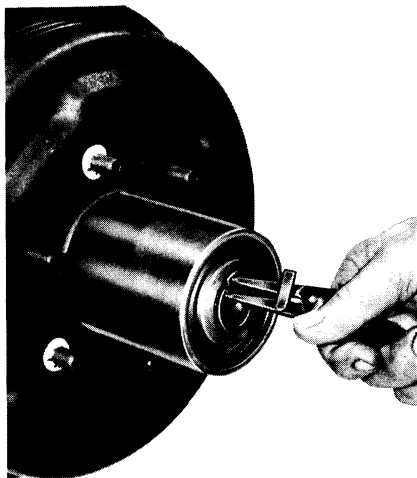

F 1812-A

FIG. 1 Removing Snap Ring

4. Remove the splined driving hub and the pressure spring. This may require a slight prying assist (Fig. 2).

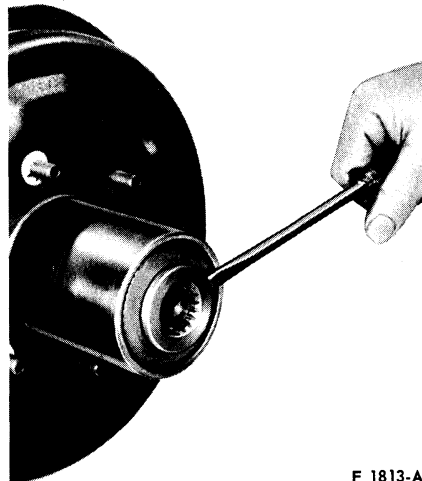

F 1813-A

FIG. 2 Removing Splined Driving Hub

5. Remove the wheel bearing lock nut and lock ring.
6. Using Tool T59T-1197-B and a torque wrench, tighten the bearing adjusting nut to 50 ft-lb while rotating the wheel back and forth to seat the bearing.
7. Back off the adjusting nut approximately 90 degrees.
8. Assemble the lock ring by turning the nut to the nearest notch for dowel pin installation.

9. Install the outer lock nut and torque 80 to 100 ft-lb. Final end play of the wheel on the spindle should be 0.001 to 0.010 inch.
10. Apply non-hardening sealer to the seating edge of the grease cap, then install the pressure spring and driving hub, driving hub snap ring and grease cap.
11. Adjust the brake if it was backed off.
12. Remove safety stands. Lower vehicle.

### F-250

Free-running hubs are standard on F-250 Models. See Removal and Installation, Free-Running Hub, in this Part.

1. Raise the vehicle and install safety stands.
2. Back off the brake adjusting screw, if necessary. Remove the wheel cover, if installed.
3. Refer to Free-Running Hub Removal, Steps 1 through 8, for detailed instruction.
4. Remove the front hub grease cap.
5. With Tool T59T-1197-B, remove lock nut and lock ring from spindle.
6. Using Tool T59T-1197-B and a torque wrench, tighten the bearing adjusting nut (Fig. 2, Part 11-02) to 50 ft-lb, while rotating the wheel back and forth to seat the bearings.
7. Back the adjusting nut off approximately 90 degrees. Assemble the lock ring by turning the nut to the nearest notch for dowel pin installation.

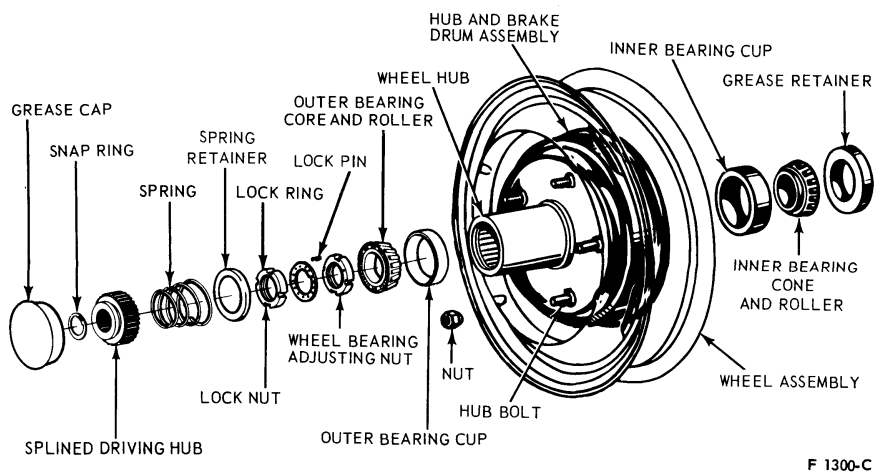

FIG. 3 Front Hub Installation—Four-Wheel Drive, Free-Running Type

8. Install the outer lock nut and torque, 80 to 100 ft-lb. Final end play of the wheel on the spindle should be 0.001 to 0.010 inch.
9. Install the front hub grease cap. Then follow Steps 1 through 10, Free-Running Hub Installation.
10. Adjust the brake, if backed off to permit drum removal.
11. Remove the safety stands and lower the vehicle.

#### F-600

1. Remove the outer hub cap retaining screws, and remove the cap.
2. Remove the retaining lock ring, as shown in Fig. 4.
3. Remove the retaining screws and splined drive plate.
4. Bend the tab of the lock washer from the lock nut and remove the lock nut (Fig. 5).
5. Remove and discard the lock washer.
6. While rotating the wheel back and forth to correctly seat the bearings,

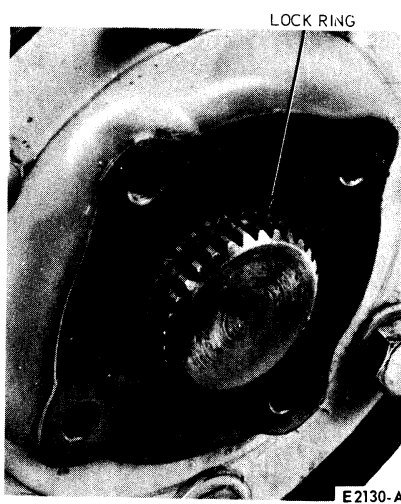

FIG. 4 Access to Lock Ring

- torque the adjusting nut to 50 ft-lb.
7. Back off the adjusting nut 1/4 to 1/3 turn.

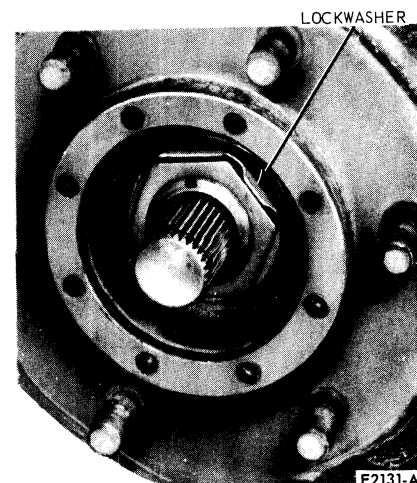

FIG. 5 Lock Nut and Washer Assembled

8. Position a **new** lock washer against the adjusting nut and apply a film of oil to the outer face of the lock washer.
9. Run the lock nut up against the lock washer and torque, 100 to 150 ft-lb.
10. Bend one tab of the lock washer over the adjusting nut.
11. Bend one tab of the lock washer (in the opposite direction) over the lock nut. **Use a blunt tool when bending the tabs to avoid making any chips which could cause serious bearing damage.**
12. Apply Silastic Sealer to the front and rear mounting faces of the splined drive plate.
13. Position the drive plate, install the retaining screws, and torque them to specification.
14. Install the retaining lock ring.
15. Position outer hub cap, install the retaining screws, and torque them to specification.

## REMOVAL AND INSTALLATION

### FREE-RUNNING HUB (INTERNAL-TYPE)

#### BRONCO, F-100, F-250 (3300-LB. AXLE)

##### Removal

1. Remove the free-running hub screws and washers (Fig. 6).
2. Remove the hub ring and the knob. Wipe the parts clean.
3. Remove the internal snap ring from the groove in the hub.
4. Remove the cam body ring and clutch retainer (as an assembly) from the hub. Disassemble the parts.
5. Remove the axle shaft snap ring. For

easier snap ring removal, push inward on the gear and, at the same time, pull out on the axle with a bolt.

6. Remove the drive gear and clutch gear. A slight rocking of the hub may make them slide out easier.
7. Remove the coil spring.
8. Remove the spring retainer ring.

##### Installation

1. Grease the hub inner spline with Moly grease (Fig. 7).
2. Install the spring retainer ring, positioned as shown (Fig. 8) with recessed undercut area going in first. Be sure ring seats against the bearing.

3. Install the coil spring with large end entering first (Fig. 9).
4. Grease with Moly grease and install the axle shaft sleeve and ring and the inner clutch ring. Be sure that the teeth are meshed together in a locked position for easy assembly. It may be necessary to rock the hub back and forth for spline alignment. Keep the two gears in locked position (Fig. 10).
5. Install the axle shaft snap ring. Push inward on gear and, if necessary, pull out axle shaft with bolt to allow groove clearance on shaft for the snap ring. Be sure snap ring is fully seated

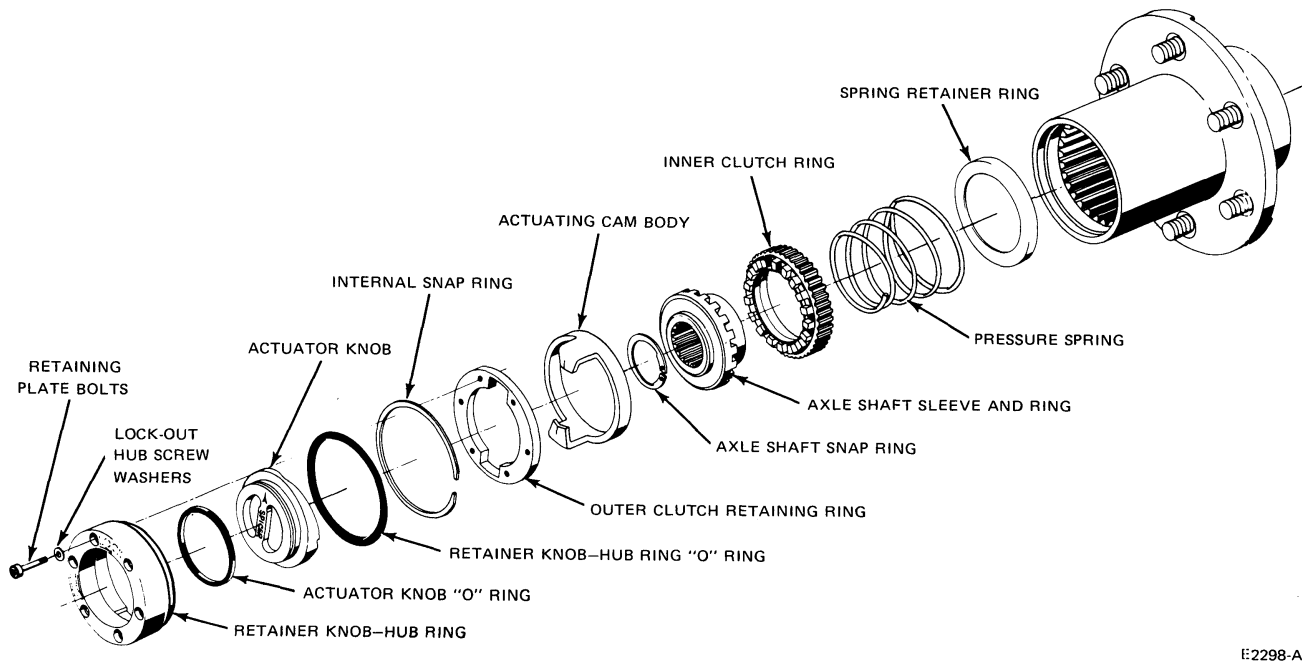

FIG. 6 Free-Running Hub—Internal-Type—Bronco, F-250 (3300-lb. Axles) Optional F-100

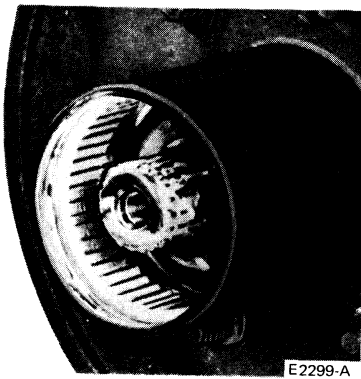

FIG. 7 Grease Application



FIG. 9 Coil Spring Installation



FIG. 8 Spring Retainer Ring Installation

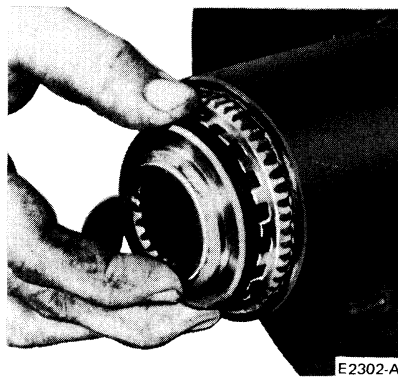

FIG. 10 Axle Shaft Sleeve and Ring and, Inner Clutch Ring Installation

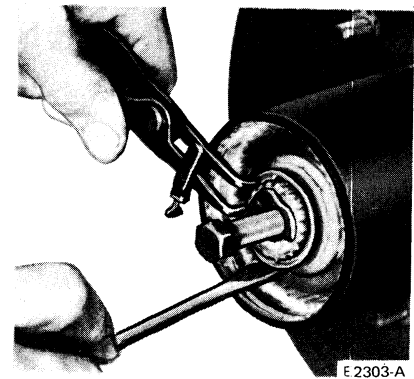

FIG. 11 Installing Axle Shaft Snap Ring

- in the snap ring groove on the shaft (Fig. 11).
6. Install the actuating cam body ring into the outer clutch retaining ring. Assemble into hub (Fig. 12).
  7. Install the internal snap ring. Be sure snap ring is fully seated in the snap ring groove of the hub (Fig. 13).
  8. Apply a small amount of Lubriplate grease on the ears of the cam (Fig. 14).
  9. Apply a small amount of Parker O-ring lube in groove of actuating knob before assembling outer O-ring (Fig. 14).
  10. Assemble knob in hub ring and assemble to axle with knob in locked

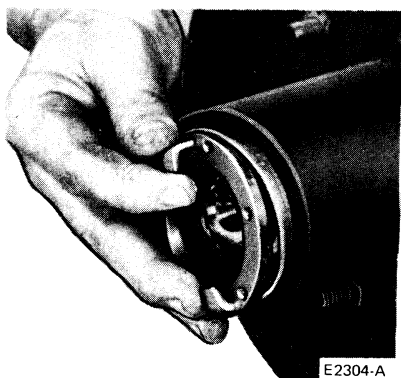

FIG. 12 Installing Cam Body Ring into the Clutch Retaining Ring

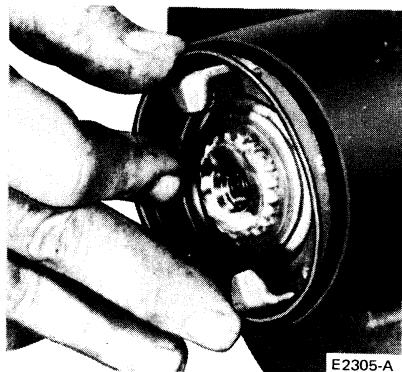

FIG. 13 Installing Internal Snap Ring

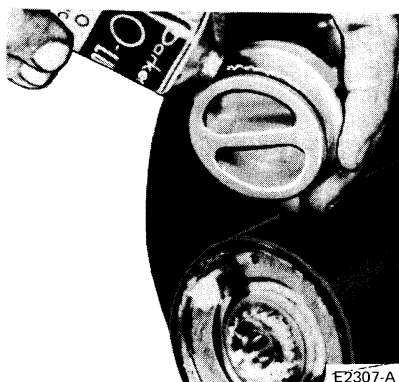

FIG. 14 Lubrication Areas

position. Assemble screws and washers alternately and evenly, making sure the retainer ring is not cocked in the hub.

11. Torque the six lock-out hub screws to 35 to 40 inch pounds. Be sure the washers are under each retaining screw. Each free-running hub will fit either wheel.

Do not drive vehicle until you are sure that both free-running hubs are engaged or disengaged. When vehicle is driven in water deep enough to cover the hubs, it is recommended that the internal parts be disassembled and inspected for possible water or dirt. After inspection, relubricate all parts before assembly to prevent rusting or corrosion.

### FREE-RUNNING HUB (EXTERNAL-TYPE)

F-250(3500-lb Axle)

#### Removal

1. Remove the free-running hub screws and washers (Fig. 15).
2. Loosen the gear hub housing and slide it away from the hub and drum assembly.
3. Remove and discard the inner metal gasket, remove gear hub housing, and remove and discard the outer gasket. Wipe clean the exposed parts.
4. Remove the snap ring while holding pressure on the clutch gear.
5. Ease the clutch gear and pressure spring out of the assembly. The actuator knob should be in the lock position for this step.
6. Turn the actuator knob to the free position. With a drift, drive the cam lock pin out of the assembly.
7. Remove the actuating cam from the knob.
8. Remove the knob retainer snap ring and remove the knob from the knob retainer.
9. Using a capscrew, pull out slightly on the axle shaft and remove the snap ring which retains the bushing and inner clutch gear assembly.
10. Remove these parts and disassemble. If wear or damage are evident on either the inner or outer clutch gear, they should both be replaced as a set.

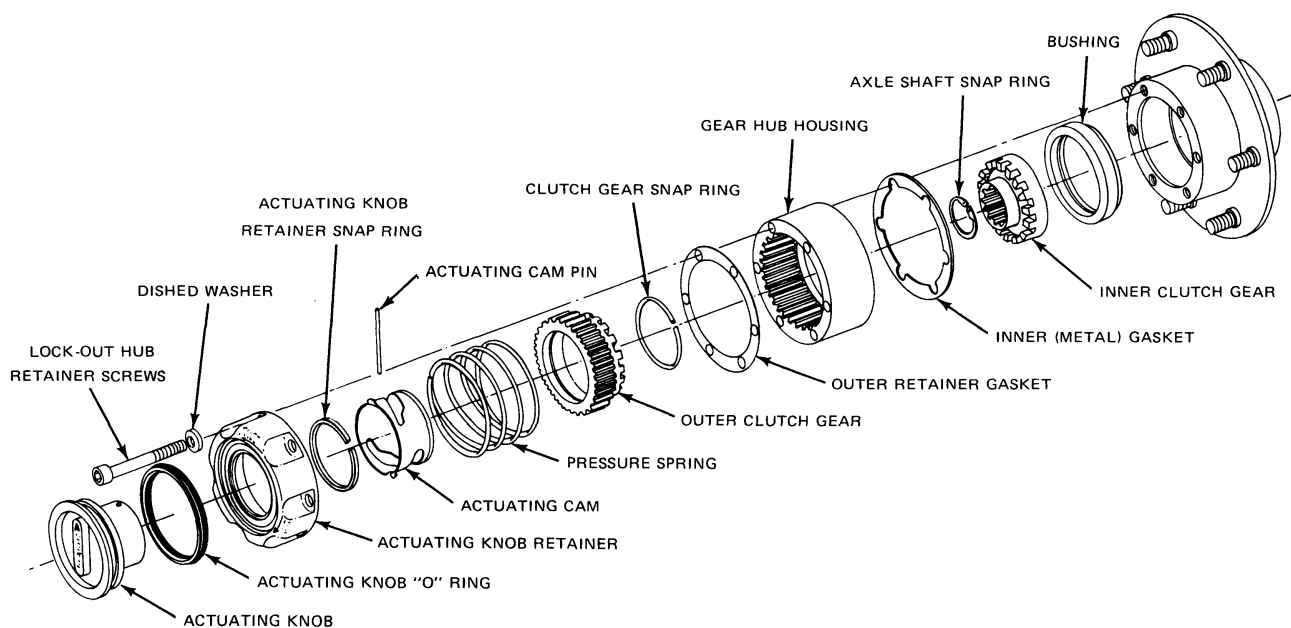

E2306-A

FIG. 15 Free-Running Hub—External-Type (F-250—3500 lb. Axles)

### Installation

Before assembling free-running hubs, inspect the splines of the axle shaft to make sure they are free of any possible nicks or burrs.

Threaded screw holes in the wheel hub should be cleaned before assembling new retainer screws. These holes can be cleaned by directing compressed air into the threaded holes.

1. Apply Moly XL hi-speed grease to the back face and the thrust face of the bushing, also to the splines of the inner clutch gear.
2. Assemble inner clutch gear into bushing.
3. Install the bushing and inner clutch gear onto axle shaft, making sure the splines of the inner clutch gear are aligned with the splines of the axle shaft, as shown (Fig. 16).

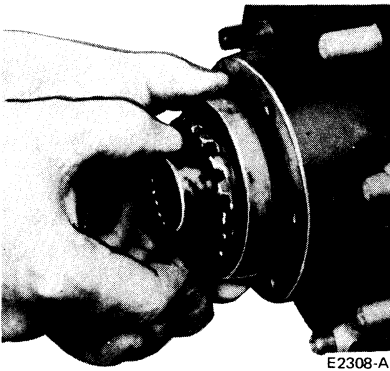

FIG. 16 Bushing and Inner Clutch Gear Installation

4. Install a new snap ring. If necessary, pull out axle shaft with capscrew to allow clearance in groove for snap ring on axle shaft. Be sure snap ring is fully seated (Fig. 17).

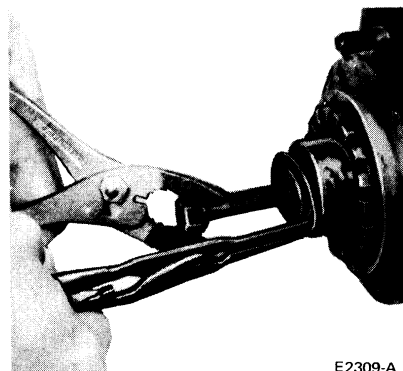

FIG. 17 Snap Ring Installation

5. Apply a small amount of Parker O-ring lubricant on the actuator knob, making sure knob is completely lubricated in the area shown.
6. Assemble O-ring onto actuating knob.

7. Install the actuating knob into the knob retainer with arrow pointing to free position.
8. Install the knob retainer snap ring. Spread snap ring with snap ring pliers. Use a small screwdriver to position the snap ring in the groove of the knob (Fig. 18).

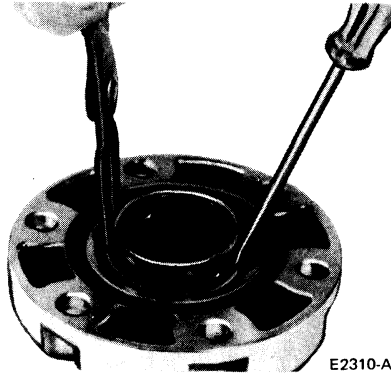

FIG. 18 Knob Retainer Snap Ring Installation

9. Install the actuating cam onto the knob, aligning the ears of the cam with slots of the retainer. Position parts on a small piece of wood.
10. Assemble the cam lock pin through the groove of the cam and holes in the actuating knob. Be sure ends of the pin are flush with the outside diameter of the cam (Fig. 19).

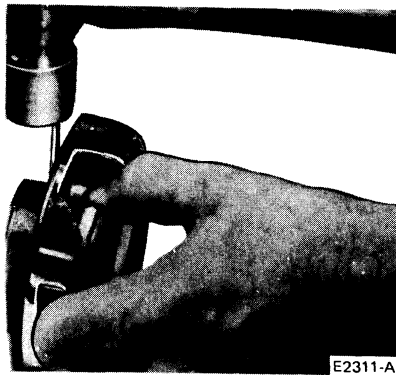

FIG. 19 Cam Lock Pin Installation

11. Turn actuator knob to lock position. Apply a small amount of Moly XL hi-speed grease to both grooves of the cam as shown (Fig. 20).
12. Install the pressure spring and outer clutch gear. Compress the pressure spring by forcing down on clutch gear and assemble snap ring (Fig. 21). Make sure snap ring is secure in the groove of the cam.
13. Turn actuator knob to free position. Assemble six dished washers to the six retainer screws exactly as shown (Fig. 22).

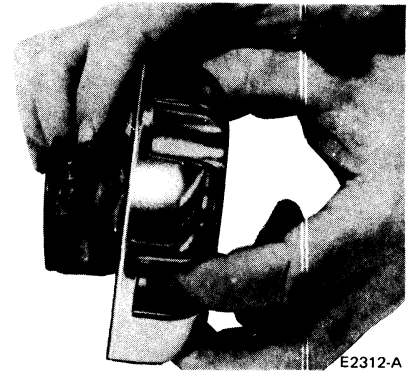

FIG. 20 Grease Application

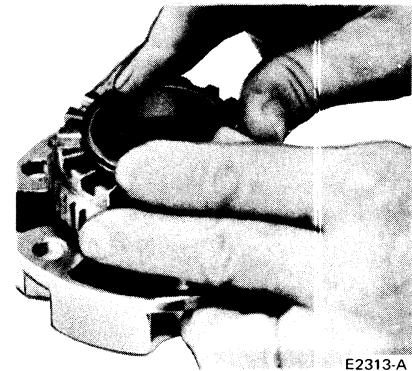

FIG. 21 Pressure Spring and Outer Clutch Gear Installation

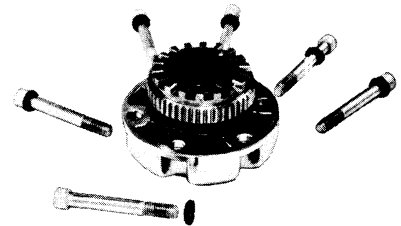
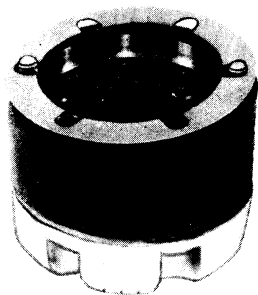

FIG. 22 Dished Washer Assembly Detail

14. Install 2 screws with correctly positioned washers into the knob retainer to properly line up the parts for Steps 15 and 16. Apply small amount of Moly hi-speed grease to the outer spline and teeth of the outer clutch gear. Remove any excess lubricant from the gasket surface of the retainer.
15. Install a new outer retainer gasket. Assemble gear hub housing by aligning the splines of the housing with those of the outer clutch gear. Then install a new inner (metal) gasket on hub housing, as shown in Fig. 23.
16. Position the free-running hub subassembly to axle assembly using the two new retainer screws as pilots.





E2315-A

FIG. 23 Assembly Positions of Gear Hub Housing and Gaskets

to align the holes of the gasket with the holes of the wheel hub. Tighten retainer screws to secure the free-running hub. Turn actuator knob to lock position.

17. Install the remaining four new retainer screws with washers. Tighten screws evenly, and torque, 30 to 35 ft-lb. The free-running hub may be hard to engage and disengage, however after use, they should loosen up for easier operation. Either free-running hub will fit either wheel.
18. Do not drive vehicle until both free-running hubs are either engaged or disengaged.

## DISASSEMBLY AND ASSEMBLY

### FRONT WHEEL GREASE SEAL AND BEARING REMOVAL AND INSTALLATION AND/OR REPACKING

The recommended wheel bearing lubricant is the lithium-base grease, ESA-M1C73-B.

Sodium-base grease is not compatible with lithium-base grease and should not be intermixed. Therefore, before lubricating front and/or rear wheel bearing, note which type was used as the original wheel bearing lubricant. Usage of incompatible bearing lubricant could result in premature lubricant breakdown.

If bearing adjustment does not eliminate looseness or rough and noisy operation, clean, inspect and repack the hub and bearings with specified wheel grease. If bearing cups or the cone and roller assemblies are worn or damaged, they should be replaced.

#### BRONCO AND F-100

1. Raise the vehicle and install safety stands.
2. Back off the brake adjusting screw if necessary. If equipped with free-running hubs (standard on Bronco, optional on F-100), refer to Free-Running Hub Removal and Installation, this Part.
3. Remove the front hub grease cap and driving hub snap ring (Fig. 1).
4. Remove the splined driving hub and the pressure spring. This may require a slight prying assist (Fig. 2).
5. Remove the wheel bearing lock nut, lock ring, and adjusting nut (Fig. 24), using Tool T59T-1197-B.
6. Remove the hub and drum assembly. The outer wheel bearing and spring retainer will slide out as the hub is removed (Fig. 25).

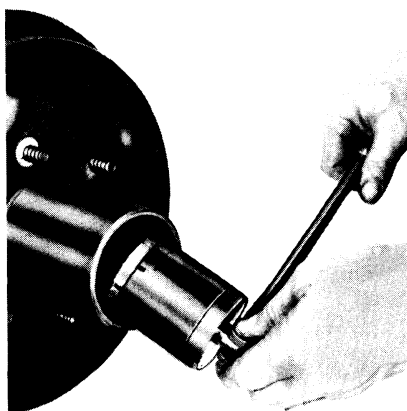

F 1814-A

FIG. 24 Lock Nut, Lock Ring and Adjusting Nut Removal

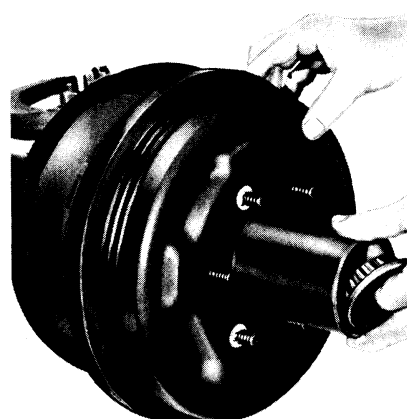

F 1815-A

FIG. 25 Hub, Drum, and Outer Bearing Removal

7. Carefully drive the inner bearing cone and grease seal out of the hub (Fig. 26) using Tool T69L-1102-A.

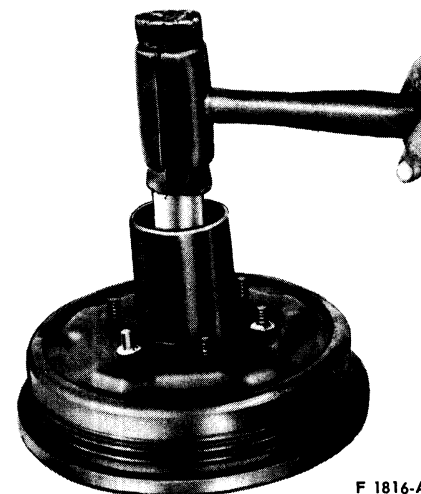

F 1816-A

FIG. 26 Inner Bearing Cone and Grease Seal Removal

8. Inspect the bearing cups for pits or cracks. If necessary, remove them with a drift (Fig. 27). If new cups are installed, install new bearings.
9. Lubricate the bearings with CIAZ-19590-B Multi-Purpose Lubricant. Clean all old grease from the hub. Pack the cones and rollers. If a bearing packer is not available, work as much lubricant as possible between the rollers and the cages.
10. Position the inner bearing cone and roller in the inner cup and install the grease retainer.
11. Carefully position the hub and drum assembly on the spindle.
12. Install the outer bearing cone and roller, and the adjusting nut.
13. Using Tool T59T-1197-B and a torque wrench, tighten the bearing

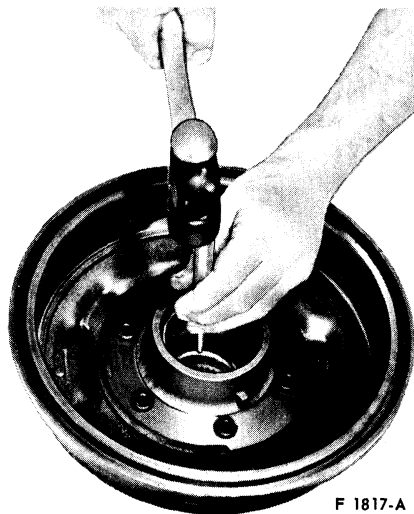

F 1817-A

FIG. 27 Bearing Cup Removal

adjusting nut to 50 ft-lb, while rotating the wheel back and forth to seat the bearings.

14. Back off the adjusting nut approximately 90 degrees.
15. Assemble the lock ring by turning the nut to the nearest notch and inserting the dowel pin.
16. Install the outer lock nut and torque, 80 to 100 ft-lb. Final end play of the wheel on the spindle should be 0.001 to 0.010 inch.
17. Install the pressure spring and driving hub snap ring.
18. Apply non-hardening sealer to the seating edge of the grease cap, and install the grease cap.
19. Adjust the brake if it was backed off.
20. Remove the safety stands and lower the vehicle.

### F-250

1. Raise the vehicle and install safety stands.
2. Back off the brake adjusting screw, if necessary. Remove the wheel cover, if installed.
3. Refer to Free-Running Hub Removal in this Part, Steps 1 through 8. Then, remove the front hub grease cap.
4. With Tool T59T-1197-B, remove the lock nut, washer, and wheel bearing adjusting nut (Fig. 3) from the spindle.
5. Remove the wheel, hub and drum as an assembly. The wheel outer bearing will be forced off the spindle at the same time. Protect the spindle and inner bearing cone from dirt.
6. Remove the grease retainer and the inner bearing cone and roller assembly from the hub with Tools 1175AB and T50T-100-A. Discard the grease retainer.
7. Clean lubricant off inner and outer bearing cups with solvent. Inspect the

8. cups for scratches, pits, excessive wear, and other damage. If worn or damaged, remove cups with a drift.
8. Thoroughly clean the inner and outer bearing cones and rollers with solvent, and dry them thoroughly. **Do not spin the bearings with compressed air.**
9. Inspect the cone and roller assemblies for wear or damage, and replace if necessary. The cone and roller assemblies and the bearing cups should be replaced as a unit if either is damaged.
10. Thoroughly clean the spindle and the inside of the hub with solvent to remove all old lubricant. Cover the spindle with a clean cloth, and brush all loose dust and dirt from the brake assembly. **To prevent getting dirt on the spindle, carefully remove the cloth from the spindle.**

11. If inner bearing cup was removed from the hub, re-install it, or replace with a new cup. **Be sure to seat the cup properly in the hub.**
12. Install the outer bearing cup in the hub with a suitable tool. **Be sure the cup is properly seated in the hub.**
13. Pack the inside of the hub with C1AZ-19590-B lubricant. Add lubricant to the hub only until the grease is flush with the inside diameter of both bearing cups.
14. All old grease should be completely cleaned from the bearings before repacking them with new grease. Pack the bearing cone and roller assemblies with C1AZ-19590-B lubricant. A bearing packer is desirable for this operation. If a packer is not available, work as much lubricant as possible between the rollers and cages. Lubricate the cone surfaces with grease.
15. Place the inner bearing cone and roller assembly in the inner cup, and install the new grease retainer. **Be sure that the retainer is properly seated.** Coat the grease retainer sealing lip with a liberal amount of C1AZ-19590-B lubricant.
16. Install the wheel, hub, and drum assembly on the wheel spindle. **Keep the hub centered on the spindle to prevent damage to the grease retainer or the spindle threads.**

17. Install the wheel outer bearing cone and adjusting nut. Adjust the front wheel bearings as detailed in Adjustments under Front Wheel Bearing Adjustment. Complete steps giving instructions for installing free-running hubs.

### F-600

1. Remove the wheel and tire from the hub and drum.

2. Remove the outer hub cap retaining screws, and remove the cap.
3. Remove the retaining lock ring (Fig. 3).
4. Remove the retaining screws and the splined drive plate.
5. Bend the tab of the lock washer away from the lock nut and remove the lock nut (Fig. 4).
6. Remove the lock washer and **discard it.**
7. Remove the adjusting nut.
8. Remove the hub and drum carefully from the spindle. Cover the spindle to protect it from dirt and foreign material. If the drum is difficult to remove, back off the brake adjustment to provide clearance.
9. Carefully remove the inner bearing and seal.
10. Clean the bearing recess and bearings with a suitable solvent. **Do not spin dry with compressed air.**
11. Repack the bearings with grease after drying thoroughly. Inspect the bearing cups. If cracked, pitted, or otherwise damaged, replace both cups and bearings. The cups can be removed using a hammer and drift.
12. Install the new cups, using Tool T68T-1174-AB for the inner bearing cup and Tool T68T-1173-AB for the outer bearing cup.
13. Install the inner bearing, lubricate, and install the grease seal using Tool T68T-1173-AC.
14. Position the hub and drum on the spindle.
15. Install the outer bearing and the adjusting nut.
16. Install the wheel and tire on the hub and drum.
17. While rotating the wheel back and forth to correctly seat the bearings, torque the adjusting nut to 50 ft-lb.
18. Back off the adjusting nut 1/4 to 1/3 turn.
19. Position a new lock washer against the adjusting nut and apply a film of oil to the outer face of the lock washer. Then, run the lock nut up against the lock washer and torque, 100 to 150 ft-lb.
20. Bend one tab of the lock washer over the adjusting nut. Then, bend one tab of the lock washer (in the opposite direction) over the lock nut. **Use a blunt tool when bending the tabs to avoid making any chips which could cause serious bearing damage.**
21. Apply Silastic Sealer to the front and rear mounting faces of the splined drive plate.
22. Position the drive plate, install the retaining screws, and torque them to specification.
23. Install the retaining lock ring
24. Position the outer hub cap and install the retaining screws.

# PART 11-14 Wheel Hubs and Bearings— Rear (Full Floating Axle)

Applies to All 250 and Higher Series Vehicles					
COMPONENT INDEX		Page	COMPONENT INDEX		Page
DESCRIPTION .....		14-01	DISASSEMBLY AND ASSEMBLY .....		14-03

## DESCRIPTION

On all the full-floating axle wheel hubs with tapered roller bearings (F-250, F-350, E-300, P-350 and P-400), a seal is installed behind the inner bearing to keep the wheel bearing lubricant from the brake lining and brake drum (Fig. 1 and 2).

The wheel bearings are packed with wheel bearing lubricant (C1AZ-19590-B) to provide initial lubrication until axle lubricant flows into the wheel hubs and bearings during vehicle operation. On these axles the wheel hub is vented through the axle housing vent. The seal assembly (500 through 9000 Series) mounts on the wheel hub and seals on a wear sleeve (wiper) which is installed on the axle housing tube (Fig. 2).

The wear sleeves (500 through 9000 Series) must be installed squarely on the axle housing using the appropriate tools (Fig. 3). Do not use heat on the wear sleeves to facilitate installation. Use the proper tool as shown in Fig. 3. The sleeves are designed with flanges to eliminate the possibility of installing them backwards.

Although preservative has been applied to the wear sleeve prior to packaging, a light oil (SAE-10 or its equivalent) should be applied to the wear sleeve to facilitate assembly of the sleeve to the axle housing.

After installation of the wear sleeve,

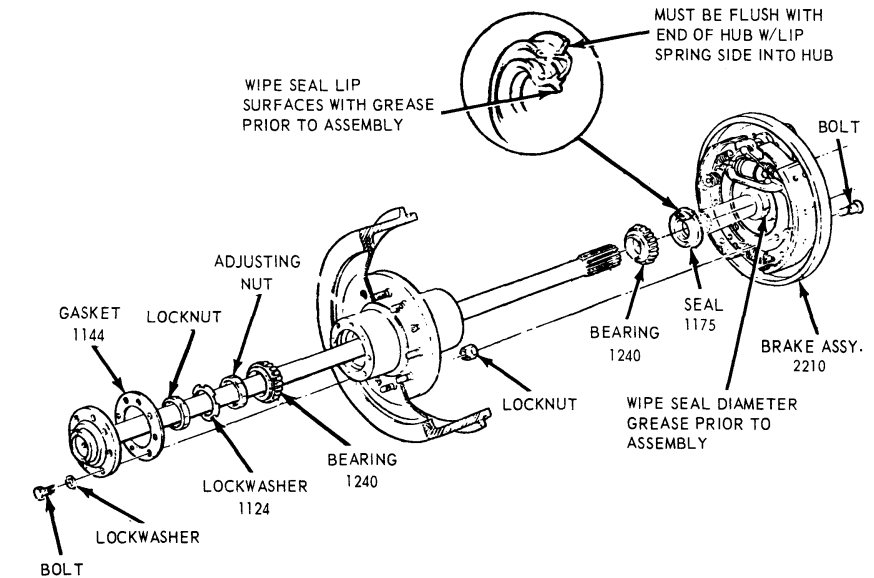

E 1972-A

FIG. 1 Rear Wheel Hub—Dana Full-Floating Axle—Models 60, 60-3E, and 70

the clearance between the end of the wear sleeve and inner wheel bearing shoulder should be 0.010 to 0.025 inch (Fig. 2).

The seal assembly is installed in the wheel hub. The garter spring should be checked to assure that the spring is in the spring groove behind the primary seal lip, after the seal is in position. Before installing the wheel, apply grease (C1AZ-19590-B) between the lips of the seal.

The wheel bearing must be thoroughly cleaned and repacked with lithium base grease (C1AZ-19590-B) before installing the wheel assembly.

To prevent damage to the primary and secondary lips of the seal assembly, a locator sleeve or tool should be used to guide the hub and drum onto the axle. A new seal assembly must be installed whenever a wheel is removed.

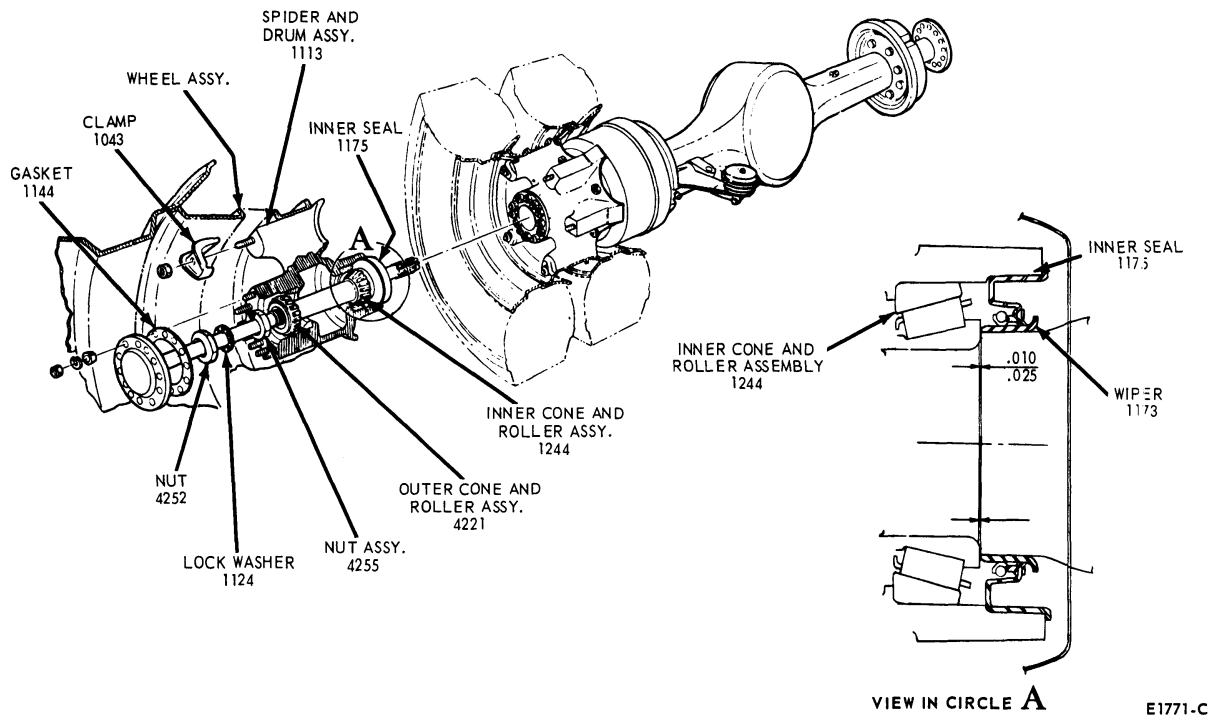

FIG. 2 Typical Rear Wheel Hub—Full-Floating Axle—500-9000 Series

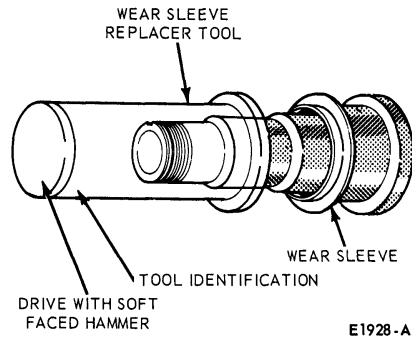

FIG. 3 Tool Application of Wear Sleeve (Wiper) Installation

## DISASSEMBLY AND ASSEMBLY

### BEARINGS, CUPS AND SEALS

#### F-250, (4 x 2 and 4 x 4), F-350, E-300, P-350, and P-400 Series

1. Set the parking brake and loosen the axle shaft retaining bolts (Fig. 1).
2. Raise the rear wheels off the floor and place work stands under the rear axle housing so that the axle is parallel with the floor. Back off the rear brake adjustment, if necessary.
3. Remove the axle shaft retaining bolts and lock washers and discard them.
4. Remove the axle shaft and discard the gasket.
5. Remove the wheel lock nut, lock washer and wheel bearing adjustment nut, using Tool T70T-4252-D or T70T-4252-E. **Under no condition should the lock nut be removed with a chisel. Discard the lock washer.**
6. With the type of wheel jack shown in Fig. 4, raise the wheel to the point that all weight is removed from the wheel bearings.

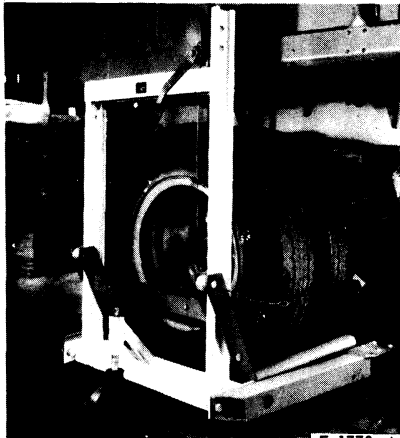

FIG. 4 Typical Wheel Jack

7. Remove the outer bearing cone, pull the wheel assembly straight out and away from the axle.
8. Thoroughly clean the spindle of the axle housing.
9. With a brass drift, drive the inner bearing cone and inner seal out of the wheel hub. Use extra care to prevent damage to the bearing cage.
10. Clean all old grease and axle lubricant out of the wheel hub.
11. Inspect the bearing races and rollers for pitting, galling or erratic wear patterns. Inspect the rollers for end wear. Replace the bearings if worn or damaged.
12. If the bearing cups are to be replaced, drive them out with a brass drift. Install the new cups with a tool such as OTC 27797.

13. Check for proper seating of the new bearing cups by trying to insert a 0.0015-inch feeler gauge between the cups and the wheel hub. The gauge should not enter beneath the cup. Check several places to make sure that cups are squarely seated.
14. Pack each bearing cone and roller assembly with a bearing packing tool, using C1AZ-19590-B (ESA-M1C75-B) long-life lubricant.
15. Place the inner bearing cone and roller assembly in the wheel hub. Install a new hub inner seal using Tool T73T-1190-A.
16. Position the wheel assembly at the axle housing. Wrap the threads of the spindle with electricians tape. **Carefully slide the wheel assembly straight (to avoid seal damage) onto the axle housing spindle. Remove the electricians tape.**
17. Install the outer wheel bearing and start the bearing adjuster nut. Remove the wheel jack.
18. While rotating the wheel, torque the adjusting nut, 50 to 80 ft-lb. Back off (loosen) the adjusting nut  $\frac{3}{8}$  of a turn using Tool T70T-4252-D or T70T-4252-E.
19. Coat a new lock washer with axle lube and install it, smooth side out. Install the lock nut (Tool T70T-4252-D or T70T-4252-E). Torque the lock nut, 90 to 110 ft-lb. With the lock nut at proper torque, the wheel assembly must rotate freely and with an end play of 0.001-0.010 inch. **Be sure of this specification. Check it closely with suitable dial indicator set up. Do not preload the bearings.**
20. With a satisfactory end play and freely turning wheel, bend two lock washer tabs inward over flats of the adjusting nut, and two tabs outward over flats of the lock nut.
21. Install the axle shaft and new axle flange gasket, lock washers and new axle shaft retaining bolts. Torque the lock bolts, 40 to 50 ft-lb.
22. Adjust the brakes.
23. Remove the work stands and lower the vehicle.

### 500-9000 Series

1. Release the parking brake and loosen the axle shaft stud nuts.
2. Raise the rear wheels off the floor and place work stands under the rear axle housing so that the axle is parallel with the floor. Back off the rear brake adjustment.
3. Remove the axle shaft stud nuts.

4. If tapered dowels are installed in the axle shaft flange, place a drift in the center of the flange and strike it sharply to loosen the dowels (Fig. 5).

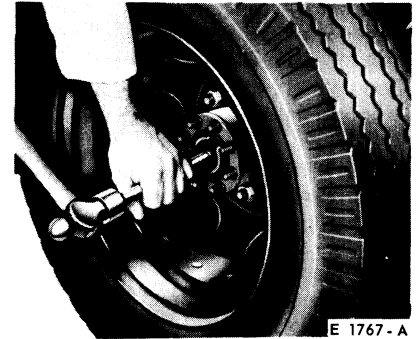

FIG. 5 Axle Shaft Removal—Tapered Dowels

5. Remove the axle shaft.

On axles where tapered dowels are not used, two puller threads (5/8-11) are provided in the axle shaft flange. These axle shafts may be pulled with a slide hammer installed in the puller threads or with the type of tool shown in Fig. 6. This tool can be made from a piece of flat steel bar with an 1 1/16-inch hole in it, and a 2-1/4 inch long 5/8-11 bolt. As the bolt is turned clockwise, the axle shaft flange is pulled away from the wheel hub. If the thread load becomes excessive when pulling an axle shaft, install a second puller on the opposite side of the flange, if so equipped.

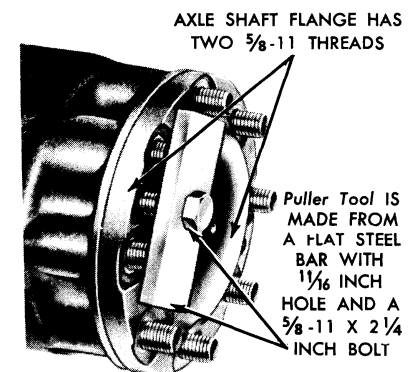

FIG. 6 Axle Shaft Puller

6. Bend the lock washer tab away from the lock nut, and remove lock nut, lock washer, and adjusting nut.

7. With the type of wheel jack shown in Fig. 4, raise the wheel so that all wheel weight is removed from the wheel bearings.
8. Remove the outer bearing cone. Pull the wheel straight out and away from the axle.
9. Inspect the inner seal wear sleeve on the axle housing spindle for signs of wear or pitting. If necessary to replace the wear sleeve, use a hammer and a cold chisel. Be careful not to damage the seal journal of the axle housing. Make two evenly spaced indentations in the wear sleeve surface and slip the wear sleeve off the axle housing.

Thoroughly clean the spindle of the axle housing. Apply a light coating of SAE 10 oil to inner surface of the wear sleeve to facilitate assembly of sleeve to axle housing.

Position a new proper size wear sleeve squarely to the axle housing spindle and, with the use of proper driving tool (Fig. 3), and a soft faced hammer, drive the wear sleeve on the axle housing spindle until it seats evenly against the shoulder of the seal journal of the spindle.

10. With a piece of hard wood which will just clear the outer bearing cup, or a brass drift, carefully drive the inner bearing cone and inner seal out of the wheel hub.
11. Clean all the old grease or axle lubricant out of the wheel hub.
12. Inspect the bearing races and rollers for pitting, galling, and erratic wear patterns. Inspect the rollers for end wear (Fig. 7).

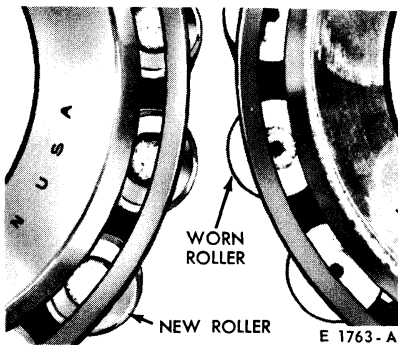

FIG. 7 Roller Bearing End Wear

13. If the bearing cups are to be replaced, drive them out with a drift. Install the new cups with the tool shown in Fig. 8 or press them in.
14. Check for proper seating of the new bearing cups by trying to insert a 0.0015 inch feeler gauge between the cup and the wheel hub.
15. Pack each bearing cone and roller assembly with a bearing packer tool.

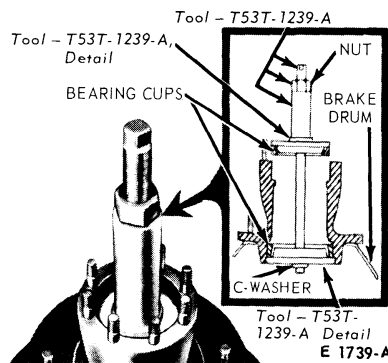

FIG. 8 Installing Bearing Cup

16. Place the inner bearing cone and roller assembly in the wheel hub, and install a new hub inner seal.
17. Apply a light film of C1AZ-19590-B (ESA-M1C75-B) to the axle spindle, and position a seal protector tool over the axle spindle threads.
18. Wheel assembly placed at the axle housing, carefully slide wheel assembly straight (to avoid seal damage) onto the axle housing spindle. Then, remove the seal protector from the axle spindle.
19. Install the outer wheel bearing and start the bearing adjuster nut. Remove the wheel jack.
20. **This Step (20) applies only to 11000- and 17500-lb. Single Rear Axles and 30000-lb. Tandem Rear Axles:**

Torque the adjusting nut to 140 ft-lb. while rotating the wheel to seat the bearings. Back off (loosen) the adjusting nut 1/2 turn; then, torque the adjusting nut again to 50 ft-lb while rotating the wheel. Back off (loosen) the adjusting nut 1/3 turn. Install the lock washer. Back off the adjusting nut, if necessary, to align the lock washer hole with the dowel pin. Install the lock nut and tighten to 125 ft-lb. The wheel assembly must rotate freely and with an end play of 0.001 to 0.010 inch. **Do not preload the bearings. (Proceed to Step 22.)**

21. **This Step (21) applies to all other Single and Tandem Rear Axles: Torque the adjusting nut to 185 ft-lb while rotating the wheel to seat the bearings. Back off (loosen) the adjusting nut 1/2 turn; then, torque the adjusting nut again to 50 ft-lb while rotating the wheel. Back off (loosen) the adjusting nut 1/6 turn.**
22. Install a new lock washer and select a tab which is centered on one of the adjusting nut flats.

Remove the lock washer and bend this tab approximately 45 degrees such that the final bend will fit flush on the nut. Reinstall the lock washer. Install the lock nut and torque it to

125 ft-lb (Fig. 9). With the lock nut at proper torque, the wheel assembly must rotate freely and with an end play of 0.001 to 0.010 inch. Do not preload the bearings.

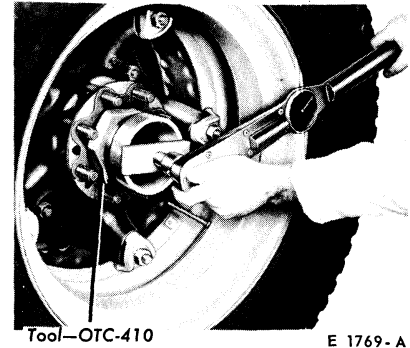

FIG. 9 Installing Lock Nut

23. Bend the pre-bent lock washer tab flush against the flat of the adjusting nut. Bend another tab flush on the lock nut. Do not use a chisel or other sharp tool to bend the tabs as metal chips could work into the bearings.
24. Install the axle shaft, a new gasket, lock washers and axle shaft retaining nuts. Torque the nuts to specifications.
25. Adjust the brakes.
26. Remove the work stands and lower the vehicle.

### MEDIUM, HEAVY AND EXTRA-HEAVY VEHICLES (OIL LUBRICATION)

Stemco Seals, available as regular production options, provide sealing where oil is used for bearing lubrication. **The tools required for Stemco Seal Installation are only available from the Stemco warehouse. Refer to specifications for the tooling required. Fig. 10 illustrates a rear wheel Stemco Seal installation.**

#### Rear Hub Seal Installation

1. Thoroughly clean the axle spindle.
2. If the spindle shoulder is scored or pitted apply a thin coat of Permatex No. 2.
3. Position the axle ring and drive it into position flush with the inner bearing shoulder using the correct tool. Procedures vary with different applications. Refer to the instructions packed with each seal set.
4. Remove all burrs and protrusions from the oil seal area of the wheel hub.
5. Pack the inner bearing cone with C1AZ-19590-B (ESA-M1C75-B) and position it in the bearing cup.

6. Pack grease between spring and seal lip to prevent spring from dislocating when seal is installed.
7. Position the oil seal at the mouth of the bore and drive it squarely into position using the correct tool. The seal must be evenly bottomed. Take special care not to damage the oil seal while installing the wheel.
8. Fill the wheel cavity with oil before installing the outer bearing.
9. Pack the outer bearing with M1C75-B and install it.
10. Adjust bearings as outlined in Step 18, under 500-9000 series.
11. Inspect axle shaft gasket mating surfaces for nicks, burrs, and dirt; then install the axle shaft.
12. Check the rear axle lube level and add oil if required.

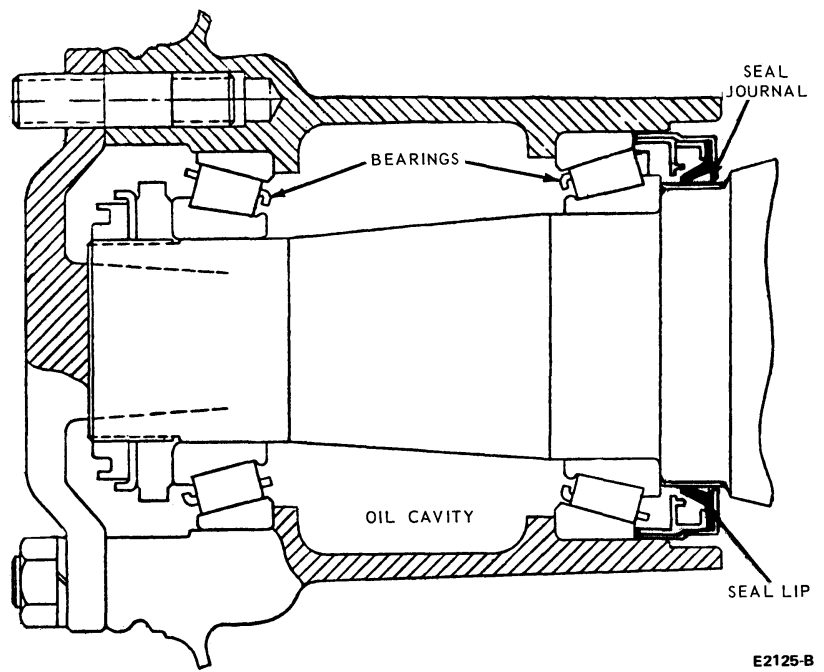

E2125-B

FIG. 10 Rear Seal Installation (Stemco)

## SPECIFICATIONS

**SPECIAL SERVICE TOOLS STEMCO<sup>①</sup>**

Ford Seal Kit Part No.	Stemco Tool No.	Ford Seal Kit Part Name
D0HZ-1175-A	5008-5308	Kit - Oil Seal Inner Rear Wheel
D0HZ-1175-B	5002-5011	
D0HZ-1175-C	5074-5383	
D0HZ-1175-D	5072-5397	
D0HZ-1175-E	5071-5391	
D0HZ-1175-F	5076-5399	

<sup>①</sup> Kits on this page consist of one axle ring and one seal for just one wheel.

CE2330-A

# Brakes

GROUP  
**12**

	Page		Page
<b>PART 12-01</b>		<b>PART 12-54</b>	
General Hydraulic Brake Service . . . . .	12-01-01	Vacuum Brake Booster – Tandem Diaphragm, Frame-Mounted (Bendix) . . . . .	12-54-01
<b>PART 12-02</b>		<b>PART 12-58</b>	
Drum Brakes – Single Cylinder, Dual Piston . . . . .	12-02-01	Vacuum Brake Booster – Single Diaphragm, Dash-Mounted (Midland) . . . . .	12-58-01
<b>PART 12-05</b>		<b>PART 12-60</b>	
Drum Brakes – Single Cylinder, Single Piston . . . . .	12-05-01	Vacuum Brake Booster – Single Diaphragm, Frame-Mounted (Midland) . . . . .	12-60-01
<b>PART 12-08</b>		<b>PART 12-70</b>	
Drum Brakes – Dual Cylinders, Dual Pistons . . . . .	12-08-01	Parking Brake – Cable Actuated, Rear Wheels . . . . .	12-70-01
<b>PART 12-09</b>		<b>PART 12-77</b>	
Drum Brakes – Dual Cylinders, Single Piston (Wagner) . . . . .	12-09-01	Parking Brake – External Band, Transmission Mounted . . . . .	12-77-01
<b>PART 12-24</b>		<b>PART 12-79</b>	
Disc Brakes—Floating and Sliding Caliper . . . . .	12-24-01	Parking Brake – Internal Shoe, Transmission Mounted . . . . .	12-79-01
<b>PART 12-40</b>		<b>PART 12-81</b>	
General Air Brake Service . . . . .	12-40-01	Parking Brake – Internal Shoe, Transfer Case Mounted . . . . .	12-81-01
<b>PART 12-43</b>		<b>PART 12-83</b>	
Air Brakes – Single Wedge (Rockwell) . . . . .	12-43-01	Parking Brake – Maxibrake, Rear Wheels, Air . . . . .	12-83-01
<b>PART 12-44</b>		<b>PART 12-84</b>	
Air Brakes – Single Wedge (Bendix) . . . . .	12-44-01	Parking Brake – MGM Stoppard- Rear Wheels, Air. . . . .	12-84-01
<b>PART 12-46</b>		<b>PART 12-85</b>	
Air Brakes – Double Wedge (Bendix) . . . . .	12-46-01	Parking Brake – MGM Shortstop, Rear Wheels, Air . . . . .	12-85-01
<b>PART 12-48</b>		<b>PART 12-86</b>	
Air Brakes – Cam Type . . . . .	12-48-01	Parking Brake – MGM Low Profile, Rear Wheels, Air . . . . .	12-86-01
<b>PART 12-50</b>		<b>PART 12-87</b>	
Vacuum Brake Booster – Single Diaphragm, Dash-Mounted (Bendix) . . . . .	12-50-01	Parking Brake – Anchor Lok, Rear Wheels Air . . . . .	12-87-01
<b>PART 12-52</b>			
Vacuum Brake Booster – Tandem Diaphragm, Dash-Mounted (Bendix) . . . . .	12-52-01		
<b>PART 12-53</b>			
Vacuum Brake Booster – Single Diaphragm, Frame-Mounted (Bendix) . . . . .	12-53-01		

**Buy Now**

